

VICTORIA UNIVERSITY



3 1761 03714 7501

CHINA MISSION
YEAR BOOK
1924

CHRISTIAN LITERATURE SOCIETY
SHANGHAI

VICTORIA UNIVERSITY LIBRARY



This book is the gift of

Frederick Clark Stephenson

M.D., D.D.

1864-1941

Pioneer Leader in Missionary Advance

Organizer of the Young People's Forward Movement for Missions in the Methodist Church and its Secretary from 1906 to 1925.

From 1925 until his retirement in 1936 Secretary of the Department of Young People's Missionary Education of the United Church of Canada.

THE CHINA MISSION YEAR BOOK 1924

(TWELFTH ISSUE)

Issued under arrangement of the Christian Literature Society for China and the National Christian Council under the direction of the following Editorial Committee appointed by the National Christian Council.

Editor-in-Chief : Rev. FRANK RAWLINSON, D.D.

Editor, Chinese Recorder

Dr. H. F. McNair
Mrs. Lawrence Thurston
Prof. T. C. Chao
Miss R. Venable
Dr. E. M. Merrins

Dr. John Y. Lee
Rev. D. MacGillivray, D.D.
Dr. H. T. Hodgkin
Rev. E. H. Cressey
Miss G. Townsend

SHANGHAI
CHRISTIAN LITERATURE SOCIETY

1924

EMMANUEL

PREFACE

THERE is no space for the Editor to attempt anything like an introductory article. The contributions are so many and varied that it is not needed. A prefatorial remark or two, however, is in order.

The China Mission Year Book is not a Year Book in the sense that the articles given are repeated and brought up-to-date each year. Neither does the China Mission Year Book deal with statistics. It aims to summarize the Christian Movement as a whole. It is in nature an annual review. It attempts to give reports on those aspects of, and problems connected with the Christian Movement in China which seem to be currently prominent. It varies considerably, therefore, from year to year.

The main point about this issue of the China Mission Year Book is the large number of new movements that are treated. A study of these should convince one that a new era in Christian work is well under way.

The attempt has been made to have the China Mission Year Book as typographically correct as possible. Each page, therefore, has been read six or eight times. For errors overlooked, of which no doubt there are plenty, the indulgent patience of the reader is asked. Thanks are due to the following for cheerful assistance in the routine and humdrum task of proof reading:—Dr. D. MacGillivray; Mr. Isaac Mason; Prof. H. F. MacNair; Rev. Carleton Lacy.

As a whole this issue of the Year Book represents the planning of the entire group of editors. For their assistance also special thanks are herewith accorded.

FRANK RAWLINSON, *Editor in Chief*

CONTENTS

PREFACE	iii
CONTENTS	iv
CONTRIBUTORS	x
 PART I. CHINA TO-DAY	

Chapter	PAGE
I. PAST AND FUTURE USE OF BOXER INDEMNITY FUNDS.....Carrol B. Malone	1
II. THE BANDIT SITUATION AND CHRISTIAN WORK Frederick G. Onley	7
III. SOCIALISTIC TENDENCIES.....D. K. Lieu	16
IV. MILITARISM.....Grover Clark	22
V. CHANGING INDUSTRIAL LIFE —	
I. South China.....Kenneth Duncan	28
II. The WuhanChas. C. Shedd	31
III. ChefooJ. W. Nipps	41
VI. WHAT IS EXTRATERRITORIALITY ? Charles Sumner Lobingier	46

PART II. CHRISTIANITY AND THE RELIGIONS OF CHINA

VII. CHANGING STANDARDS IN MORALS AND RELIGION Guy. W. Sarvis	50
VIII. RECENT RELIGIOUS MOVEMENTS.....Gilbert Reid	59
IX. THE PRESENT STATUS OF CONFUCIANISM F. C. M. Wei	67
X. THE NEW CHRISTIAN APPROACH TO BUDDHISTS Karl L. Reichelt	73
XI. CHINESE ISLAM AS AN ORGANISM Mark Edwin Botham	78
XII. CHRISTIAN WORK AMONG CHINESE MOSLEMS Isaac Mason	86

PART III. THE CHURCH IN CHINA

Chapter	PAGE
XIII. PROGRESS AND PROBLEMS OF THE CHRISTIAN MOVEMENT SINCE THE REVOLUTION (1911) Edwin Marx	89
XIV. RECENT DEVELOPMENTS IN CHINESE CHURCH LIFE	
1. West China.....R. O. Jolliffe	100
2. East Central China.....W. P. Roberts	103
3. North China.....George L. Davis	106
4. Fukien.....Willard L. Beard	111
5. South China.....A. J. Fisher	114
6. Wuhan Alfred A. Gilman	119
7. Manchuria F. W. S. O'Neill	123
XV. THE RURAL CHURCH AND ITS RELATION TO RELIGIOUS, EDUCATIONAL, MEDICAL AND SOCIAL WORK.....K. T. Chung	127
XVI. THE CHINESE CHURCH AND CHANGING CHINA T. C. Chao	131
XVII. THE STATUS OF SELF-SUPPORT Robert E. Chandler	138
XVIII. THE COMMUNITY CHURCH IN CHINA R. T. Henry	143

PART IV. THE COÖPERATIVE MOVEMENTS IN CHINA

XIX. THE FORWARD PROGRAM OF THE NATIONAL CHRISTIAN COUNCIL Henry T. Hodgkin	147
XX. THE NATIONAL CHRISTIAN COUNCIL AND THE CHURCH IN CHINA.....L. J. Birney	151
XXI. PRESENT TENDENCIES IN THE CHINESE Y. M. C. A. David Z. T. Yui	158
XXII. SOME MODERN ASPECTS OF THE YOUNG WOMEN'S CHRISTIAN ASSOCIATION IN CHINA.....Mrs. T. C. Chu, Miss Ting Shu-ching, Miss Theresa Severin.....	167
XXIII. CHINESE HOME MISSIONARY SOCIETY	172
XXIV. HUNAN BIBLE INSTITUTE.....Frank A. Keller	175
XXV. COÖPERATION IN THE C. I. M.....D. E. Hoste	180
XXVI. CHURCH FEDERATION IN CHINESE CITIES J. S. Burgess	184
XXVII. DAILY VACATION BIBLE SCHOOL.....S. P. Ch'ian	189

Chapter	PAGE
XXVIII. CHINA SUNDAY SCHOOL UNION E. G. Tewksbury	191
XXIX. CHINA CHRISTIAN ENDEAVOUR UNION E. E. Strother	196
XXX. THE EPWORTH LEAGUE.....Geraldine Townsend	198
XXXI. THE CHRISTIAN PUBLISHERS' ASSOCIATION J. Whitsed Dovey	202
PART V. SPECIAL EVANGELISTIC MOVEMENTS	
XXXII. SOME PROBLEMS OF EVANGELISTIC WORK	
1. In the Church.....Ting Li Mei	205
2. Of Itineration..... J. Goforth	208
3. In Rural Fields W. A. Mather	210
XXXIII. THE WORK OF THE UNITED METHODIST MISSION IN WENCHOW Wm. R. Stobie	213
XXXIV. TENT EVANGELISM.....Andrew Thompson	222
XXXV. WORK AMONG THE SHANS J. W. Lowrie	226
XXXVI. WORK IN HAINAN.....David S. Tappan	230
XXXVII. WORK AMONG TURKI AND THE TRIBES IN CENTRAL ASIA.....G. W. Hunter	235
PART VI. MISSIONS AND MISSIONARIES	
XXXVIII. THE FINANCIAL RESOURCES OF THE HOME BASE J. L. Stuart	238
XXXIX. WHAT SHOULD BE THE PRESENT CONTRIBUTION OF MISSIONS TO CHRISTIAN WORK IN CHINA? T. K. Shen	242
XL. RECENT CHANGES IN MISSION ORGANIZATION James Maxon Yard	247
XLI. THE MISSIONARY SUPPLY FROM NORTH AMERICA Burton St. John	252
XLII. THE METHODIST CENTENARY MOVEMENT James Maxon Yard	257
XLIII. THE MISSIONARY SITUATION IN GREAT BRITAIN Nelson Bitton	260
XLIV. ROMAN CATHOLIC MISSIONS IN CHINA Eliza L. Roots	266
PART VII. EDUCATION AND STUDENTS	
XLV. GROWTH OF UNIFICATION IN EDUCATION Donald Roberts	270

Chapter	PAGE
XLVI. GOVERNMENT RELATIONSHIPS AND CHRISTIAN EDUCATION	Earl Herbert Cressy 274
XLVII. THE PRESENT SITUATION IN RELIGIOUS EDUCATION	William L. Sanders 278
XLVIII. SCIENCE EDUCATION IN CHINA...	George R. Twiss 283
XLIX. THE MOVEMENT FOR THE SCIENTIFIC MEASUREMENT OF EDUCATION IN CHINA.....	T. T. Lew 288
L. PRELIMINARY SUMMARY AND REPORT OF THE NATIONAL EDUCATIONAL SURVEY	Earle L. Terman 297
LI. STUDENT VOCATIONAL INTERESTS...	A. J. Bowen 301
LII. UNION COLLEGES FOR WOMEN	Matilda C. Thurston 307
LIII. THE POPULAR EDUCATION MOVEMENT...	J. C. YEN 309
LIV. THE MOVEMENT FOR AN ALPHABET AND FOR THE SIMPLIFICATION OF THE CHARACTERS	Yü-t'ang Lin 318
LV. PRESENT USE OF PHONETIC SYSTEMS IN TEACHING ILLITERATES TO READ THE BIBLE	Arnold G. Bryson 325
LVI. THE STUDENT VOLUNTEER MOVEMENT	Jung Fang Li 340
LVII. CHINESE STUDENTS ABROAD.....	Y. Y. Tsu 343
LVIII. SCHOOLS FOR MISSIONARIES' CHILDREN	Charles L. Boynton 353
PART VIII. MEDICAL WORK	
LIX. THE PUBLIC HEALTH MOVEMENT IN CHINA — 1922-1923.....	John B. Grant 358
LX. WORK OF THE PEKING UNION MEDICAL COLLEGE	Henry S. Houghton 363
LXI. PHYSICAL CONDITION OF STUDENTS IN MISSION SCHOOLS.....	S. M. Woo 367
LXII. INTERDENOMINATIONAL AND NATIONAL SERVICE OF THE CHINA MEDICAL MISSIONARY ASSOCIATION	James L. Maxwell 374
LXIII. NURSES' WORK IN CHINA.....	Cora E. Simpson 378
LXIV. THE AMERICAN RED CROSS IN CHINA	382
LXV. KULING MEDICAL MISSION.....	Calvin E. Buswell 385

PART IX. SOCIAL AND INDUSTRIAL PROBLEMS

Chapter	PAGE
LXVI. PRESENT INDUSTRIAL OPPORTUNITY BEFORE THE CHURCH.....Wei Tsung Zung	388
LXVII. CHRISTIAN INDUSTRIAL ENTERPRISES Lily K. Haass	394
LXVIII. OPIUM AND NARCOTICS...W. H. Graham Aspland	399
LXIX. FAMINE RELIEF WORK—1921—1922... Y. S. Djang	410
LXX. THE MORAL WELFARE LEAGUE OF SHANGHAI Isaac Mason	413
LXXI. DOOR OF HOPE AND CHILDREN'S REFUGE Ethel Abercrombie	416
LXXII. THE PRESENT SITUATION OF THE ANTI-FOOT BINDING MOVEMENT.....Martha E. Pyle	419
LXXIII. YANGTZEPOO AND OTHER COMMUNITY CENTERS D. Y. Tsien	422
LXXIV. WORK FOR RICKSHA MEN J. C. Clark	426
LXXV. WORK AMONG THE CHINESE BLIND George B. Fryer	430

PART X. LITERATURE

LXXVI. BIBLE DISTRIBUTION DURING THE YEAR G. Carleton Lacy	432
LXXVII. THE PRESENT SITUATION WITH REGARD TO CHRISTIAN LITERATURE.....Elijah S. Nieh	438
LXXVIII. THE CHINA CHRISTIAN LITERATURE COUNCIL H. J. Molony	443
LXXIX. THE CHRISTIAN LITERATURE SOCIETY D. MacGillivray	446
LXXX. THE RELIGIOUS TRACT SOCIETY FOR CHINA George A. Clayton	448
LXXXI. CHINA AS INTERPRETED TO THE OCCIDENT BY THE RECENT BOOKS.....Kenneth Latourette	450
LXXXII. SOME CHINESE BOOKS RECENTLY PUBLISHED T. C. Chao	457
LXXXIII. NEW PUBLICATIONS IN CHINESE FROM OCTOBER 1ST, 1922 TO SEPTEMBER 31ST, 1923 George A. Clayton	466
LXXXIV. BOOKS ON SEX AND FAMILY LIFE Ella W. MacNeil	483

PART XI. MISCELLANEOUS

Chapter	PAGE
LXXXV. GOVERNOR YEN AND HIS WORK IN SHANSI Paul L. Corbin	486
LXXXVI. THE SALVATION ARMY IN CHINA Francis W. Pearce	490
LXXXVII. THE CHINESE ABROAD..... H. F. MacNair	493
LXXXVIII. WORK AMONG CHINESE SOLDIERS Rev. Liu Fang	504
LXXXIX. CHINESE LAWS AFFECTING WOMEN Chu Feng-ch'ih	508
 PART XII. OBITUARIES (1922-1923)	 512

PART XIII APPENDICES

A. BIBLIOGRAPHY..... F. Rawlinson	516
Books:—	516
Articles:—	519
B. TENT EQUIPMENT	527
C. COVENANT OF THE ASSOCIATION FOR THE SALVA- TION OF NATIONS THROUGH CHRISTIANITY	529
D. CONSTITUTION OF THE CENTRAL CHINA TEACHERS' COLLEGE	531
E. LIST OF ANTI-NARCOTIC BOOKS	533

CONTRIBUTORS

	PAGE
Abercrombie, Miss Ethel (1898)* DOOR OF HOPE AND CHILDREN'S REFUGE. In charge of receiving home and Mixed Court Work, Door of Hope, Shanghai	416
Aspland, W. H. Graham, M.D., C.M., F. R. C. S. E. (1905) OPIUM AND NARCOTICS. S. P. G. General Secretary, International Anti-Opium Association, Peking	399
Beard, Willard L., B.A., D.D. (1894) RECENT DEVELOPMENTS IN CHINESE CHURCH LIFE (Fukien). A. B. C. F. M. President, Foochow College, Mission Secretary	111
Birney, Bishop L. J. (1920) THE NATIONAL CHRISTIAN COUNCIL AND THE CHURCH IN CHINA. M. E. Bishop of the Shanghai Area	154
Bitton, Rev. Nelson, THE MISSIONARY SITUATION IN GREAT BRITAIN	260
Botham, Mark Edwin (1903) CHINESE ISLAM AS AN ORGANISM. C. I. M. Evangelistic work among Mohammedans in N. W. China	78
Bowen, Rev. A. J., B.A., LL.D. (1897) STUDENT VOCATIONAL INTERESTS M. E. President University of Nanking, Nanking... ..	301
Boynton, Rev. Charles L., B.A. (1906) SCHOOLS FOR MIS- SIONARIES' CHILDREN. Acting Principal, Shanghai American School, Shanghai... ..	353
Bryson, Rev. Arnold G. (1903) PRESENT USE OF PHONETIC SYSTEMS IN TEACHING ILLITERATES TO READ THE BIBLE. L. M. S. Country evangelistic work. Tsang Chow, Chilli	325
Burgess, Mr. J. S. (1909) CHURCH FEDERATION IN CHINESE CITIES. Secretary, Y. M. C. A., Peking	184
Buswell, Calvin E., A.B., M.D. (1919) KULING MEDICAL MISSION. P. N. Physician, Kuling Medical Mission (Chinese), and Kuling Estate Hospital (Foreign)	385

*Year of arrival in China.

	PAGE
Chandler, Robert E., B.D., M.A. (1911) THE STATUS OF SELF-SUPPORT. A. B. C. F. M. General Secretary of North China Kung Li Hui, Tientsin	138
Chao, T. C., M.A., B.D. THE CHINESE CHURCH AND CHANGING CHINA, SOME CHINESE BOOKS RECENTLY PUBLISHED. M. S. Dean of College of Arts and Sciences, Soochow University, Soochow	131
Chu, Mr. Feng-ch'ih. CHINESE LAWS AFFECTING WOMEN. Educated at Hangchow Law School. Secretary to the Civil Governor and Head of the National Bank of Commerce, Hangchow	508
Chu, Mrs. T. C., B.A. SOME MODERN ASPECTS OF THE YOUNG WOMEN'S CHRISTIAN ASSOCIATION IN CHINA. Formerly Chairman, National Committee, Y. W. C. A. ...	167
Chuan, Mr. S. P. DAILY VACATION BIBLE SCHOOL. Office Secretary and Secretary of Publication Department of the National Christian Council of China, Shanghai ...	189
Chung, Rev. K. T., B.A. THE RURAL CHURCH AND ITS RELATION TO RELIGIOUS, EDUCATIONAL, MEDICAL AND SOCIAL WORK. Chung Hua Shen Kung Hui. Secretary of National Christian Council, Shanghai	127
Clark, J. C., B.S. (1911) WORK FOR RICKSHA MEN. Y. M. C. A. Secretary, Shanghai.	
Clark, Grover, A.B., A.M. (1920) MILITARISM. Professor of English Literature, Peking National University: Managing Editor, Peking Leader	22
Clayton, Rev. George A. (1895) THE RELIGIOUS TRACT SOCIETY FOR CHINA, NEW PUBLICATIONS IN CHINESE FROM OCTOBER 1st, 1922 TO SEPTEMBER 31st, 1923. General Secretary, Religious Tract Society for China, Hankow	448
Corbin, Paul L., D.D. (1904) GOVERNOR YEN AND HIS WORK IN SHANSI. A. B. C. F. M., Taiku, Shansi	486
Cressy, Earl Herbert, (1910) GOVERNMENT RELATIONSHIPS AND CHRISTIAN EDUCATION. A. B. C. F. M. S. Chairman National Committee on Government Relationships. General Secretary, East China Christian Educational Association, Shanghai	274
Davis, George L., M.A., D.D. (1902) RECENT DEVELOPMENTS IN CHINESE CHURCH LIFE (North China). M. E. District missionary, Peking City district; Secretary, North China Mission, Peking	106

	PAGE
Djang, Mr. Y. S., B.A. FAMINE RELIEF WORK 1921-1922. Associate Executive Secretary, China International Famine Relief Commission	410
Dovey, J. Whitsed, (1917) THE CHRISTIAN PUBLISHERS' AS- SOCIATION. Secretary, Christian Publishers' Association of China, Shanghai	202
Duncan, Kenneth, Ph.D. (1911) CHANGING INDUSTRIAL LIFE (South China). Professor of Economics; Dean of Faculty of College of Arts and Sciences, Canton Christian College, Canton ...	28
Fang, Rev. Liu, B.A., WORK AMONG CHINESE SOLDIERS. M. E. Church. District Superintendent Peking District	504
Fisher, Rev. A. J., (1902) RECENT DEVELOPMENTS IN CHINESE CHURCH LIFE (South China). P. N. Evangelistic work: Associate Executive Secretary of the Church of Christ in China, Canton, Kwangtung ...	114
Fryer, Mr. George B. (Born Shanghai 1877: returned to China 1898). WORK AMONG THE CHINESE BLIND. Superintendent and Secretary Institution Chinese Blind. Director Shanghai Benevolent Industrial Inst., Shanghai	430
Gilman, Rev. Alfred A., B.A., (Nebraska) S. T. D. (Philadel- phia), (1902) RECENT DEVELOPMENTS IN CHINESE CHURCH LIFE (Wuhan). (P. E. U. S. A.) President, Boone University, Wuchang	119
Goforth, Rev. Jonathan, D.D., (1888) SOME PROBLEMS OF EVANGELISTIC WORK (Of Itineration). C. P. M. General evangelistic work. Changtehfu, Honan	208
Grant, John B., (1918) THE PUBLIC HEALTH MOVEMENT IN CHINA 1922-23. International Health Board, Rockefeller Foundation. Associate Professor Hygiene and Public Health, P. U. M. C., Peking	358
Haass, Miss Lily K., (1914) CHRISTIAN INDUSTRIAL ENTER- PRISES. Y. W. C. A. Secretary, Peking... ..	394
Henry, R. T., (1919) THE COMMUNITY CHURCH IN CHINA. M. E. S. Kong Hong Institutional Church, Soochow. Acting Executive Secretary China Association of Com- munity Church Workers. Soochow, Kiangsu	143
Hodgkin, Henry T., M.A., M.B., (1905) THE FORWARD PROGRAM OF THE NATIONAL CHRISTIAN COUNCIL. F. F. M. A. Secretary, National Christian Council, Shanghai	147
Hoste, Mr. D. E., (1885) CO-OPERATION IN THE C. I. M. Director C.I.M., Shanghai	180

Houghton, Henry S., Ph.B., M.D., (1906) WORK OF THE PEKING UNION MEDICAL COLLEGE. Director P. U. M. C. Acting Resident Director China Medical Board, Peking	363
Hunter, G. W., (1889) WORK AMONG TURKI AND THE TRIBES IN CENTRAL ASIA. C. I. M. Tihwa, Sinkiang	235
Jolliffe, R. O., B.A., (1904) RECENT DEVELOPMENTS IN CHINESE CHURCH LIFE (West China). C. M. M. Chengtu, Szechwan	100
Keller, Rev. Frank A., B.A., M.D., (1897) HUNAN BIBLE INSTITUTE. C. I. M. Superintendent, Hunan Bible Institute, Changsha, Hunan	175
Lacy, Rev. G. Carleton, M.A., B.D., (1914) BIBLE DISTRIBUTION DURING THE YEAR. Agency Secretary, American Bible Society, Shanghai ...	432
Latourette, Prof. Kenneth, (1910) CHINA AS INTERPRETED TO THE OCCIDENT BY THE RECENT BOOKS. Formerly a member of Yale Mission, Changsha, and now occupying the Chair of Missions in Yale University ...	450
Lew, Dr. T. T., THE MOVEMENT FOR THE SCIENTIFIC MEASUREMENT OF EDUCATION IN CHINA. Dean of Faculty of Theology and Professor of Psychology, Peking University... ..	288
Li, Rev. Jung-Fang, M.A., B.D., Th.D. THE STUDENT VOLUNTEER MOVEMENT. M. E. Professor, School of Theology, Peking University, Peking	340
Lieu, D. K., B.A., F. R. S. A., SOCIALISTIC TENDENCIES. Chief of Investigation Department, Government Bureau of Economic Information; Technical Expert, Financial Readjustment Commission and Special Tariff Conference Preparation Bureau, Peking	16
Lobingier, Charles Sumner, Dr. Jur., D. C. L., Ph.D., WHAT IS EXTRATERRITORIALITY? Judge U. S. Court and American Judicial Superintendent in China, Shanghai	46
Lowrie, Rev. J. W., D.D., (1883) WORK AMONG THE SHANS. P. N. Chairman of the China Council, Shanghai	226
MacGiffivray, D., M.A., D.D., LL.D., (1888) THE CHRISTIAN LITERATURE SOCIETY. C. P. M. General Secretary, Christian Literature Society, Shanghai	446

	PAGE
MacNair, H. F., Ph.D., (1912) THE CHINESE ABROAD. A. C. M. Professor of History and Government, St. John's University, Shanghai 493	493
MacNeill, Miss Ella W., (1915) BOOKS ON SEX AND FAMILY LIFE. Y. W. C. A. Student Field Secretary, Shanghai 483	483
Malone, Rev. Carroll B., (1911) PAST AND FUTURE USE OF BOXER INDEMNITY FUNDS. Professor of History, Tsing Hua College, Peking 1	1
Marx, Edwin, A.B., B.D., (1918) PROGRESS AND PROBLEMS OF THE CHRISTIAN MOVEMENT SINCE THE REVOLUTION (1911). U. C. M. S. Professor of English, University of Nanking. Since 1922, Secretary, Treasurer and Chairman of Advisory Committee of U.C.M.S. 89	89
Mason, Isaac, F. R. G. S., (1892) CHRISTIAN WORK AMONG CHINESE MOSLEMS. THE MORAL WELFARE LEAGUE OF SHANGHAI. F. F. M. A., Editorial Secretary, Christian Literature Society, Shanghai 86	86
Mather, William Arnot, B.A., B.D., (1902) SOME PROBLEMS OF EVANGELISTIC WORK (In Rural Fields). P. N. Evangelistic work. Paoting, Chihli 210	210
Maxwell, James L., M.D., B.S., London (1901) INTERDENOMINA- TIONAL AND NATIONAL SERVICE OF THE CHINA MEDICAL MISSIONARY ASSOCIATION. E. P. M. Executive Secretary, China Medical Missionary Association, Shanghai 374	374
Molony, Rev. H. J., D.D., Bishop, (1900) THE CHINA CHRISTIAN LITERATURE COUNCIL. C. M. S., Bishop in Chekiang, Ningpo 443	443
Nieh, Mr. Elijah S., B.A., THE PRESENT SITUATION WITH REGARD TO CHRISTIAN LITERATURE. Editorial Secretary, Christian Literature Society for China, Shanghai 438	438
Nipp, J. W., (1913) CHANGING INDUSTRIAL LIFE (Chefoo). Y. M. C. A. Secretary, Chefoo, Shantung 41	41
O'Neill, Rev. F. W. S., M.A., (1897) RECENT DEVELOPMENTS IN CHINESE CHURCH LIFE (Manchuria). I. P. M. Evangelistic and Educational work, Fakumen, Manchuria 123	123
Onley, Rev. Frederick G., (1909) THE BANDIT SITUATION AND CHRISTIAN WORK. L. M. S. Tsaoshih, Hupeh 7	7
Pearce, Francis W., (1920) THE SALVATION ARMY IN CHINA. Commander of Salvation Army work in North China, Peking 490	490

	PAGE
Pyle, Miss Martha E., (1892) THE PRESENT SITUATION OF THE ANTI-FOOT BINDING MOVEMENT. M. E. S. C. L. S., Editorial Secretary, Shanghai... ..	419
Rawlinson, Rev. Frank, M.A., D.D., (1902) BIBLIOGRAPHY. A. B. C. F. M. Editor, Chinese Recorder	516
Reichelt, Rev. Karl L., (1903) THE NEW CHRISTIAN APPROACH TO BUDDHISTS. N. M. S. Christian Mission to Buddhists, Nanking	73
Reid, Gilbert, Rev. A.M., D.D., (1882) RECENT RELIGIOUS MOVEMENTS. Originally P. N. Since 1894 in International Institute, Peking	59
Roberts, Donald, M.A., (1915) GROWTH OF UNIFICATION IN EDUCATION. A. C. M. Professor of History, St. John's University, Shanghai	270
Roberts, Rev. W. P., (1914) RECENT DEVELOPMENTS IN CHINESE CHURCH LIFE (East Central China). A. C. M. Evangelistic Work, Nanking	103
Roots, Mrs. H. L., (1899) ROMAN CATHOLIC MISSIONS IN CHINA, Hankow	266
Sanders, Rev. William L., (1920) THE PRESENT SITUATION IN RELIGIOUS EDUCATION. M. E. M. Secretary, Sunday School Work in China, Nanking	278
Sarvis, Guy W., M.A., (1911) CHANGING STANDARDS IN MORALS AND RELIGION. U. C. M. S. Professor of Sociology and Economics, Nanking University	50
Severin, Miss Theresa, M.A., (1913) SOME MODERN ASPECTS OF THE YOUNG WOMEN'S CHRISTIAN ASSOCIATION IN CHINA. Y. W. C. A. National Secretary for City Work, Shanghai	167
Shedd, Chas. C., B.A., (1916) CHANGING INDUSTRIAL LIFE (Wuhan). Formerly Y. M. C. A. Secretary for Industrial Work, Wu-han. Now in Chungking, Szechwan	31
Shen, T. K., WHAT SHOULD BE THE PRESENT CONTRIBUTION OF MISSIONS TO CHRISTIAN WORK IN CHINA? Presbyter, Chung Hua Sheng Kung Hui, Nanking	242
Simpson, Miss Cora E., R.N., (1907) NURSES' WORK IN CHINA. M. E. M. General Secretary, Nurses' Association of China, Shanghai	378
St. John, Burton, THE MISSIONARY SUPPLY FROM NORTH AMERICA. Student Volunteer Movement for Foreign Missions, New York	252

	PAGE
Stobie, Rev. Wm. R., (1896) THE WORK OF THE UNITED METHODIST MISSION IN WENCHOW. U. M. C. General mission work, Wenchow, Chekiang ...	213
Strother, Mr. E. E., (1900) CHINA CHRISTIAN ENDEAVOR UNION. General Secretary, China Christian Endeavor Union, Shanghai	196
Stuart, J. L., B.D., D.D., (Born Hangchow 1876; returned to China 1906) THE FINANCIAL RESOURCES OF THE HOME BASE P. S. President, Yenching University, Peking	238
Tappan, Rev. David S., A.M., (1906) WORK IN HAINAN. A. P. M. Principal, Hainan Christian Middle School, Member of China Council, Kiungchow, Hainan Island ...	230
Terman, Mr. Earle L., (1916) PRELIMINARY SUMMARY AND REPORT OF THE NATIONAL EDUCATIONAL SURVEY. M. E. M. Professor in Yenching University, Director of National Educational Survey	297
Tewksbury, Rev. E. G., (1890) CHINA SUNDAY SCHOOL UNION. General Secretary, China S. S. Union, Shanghai	191
Thomson, Rev. Andrew, B.A., (1906) TENT EVANGELISM. C. P. M. Evangelistic work, Taokou, Honan	222
Thurston, Matilda C., (1902) UNION COLLEGES FOR WOMEN. P. N. President Ginling College, Nanking	307
Ting, Mr. Li Mei. SOME PROBLEMS OF EVANGELISTIC WORK (In the Church). Secretary, Student Volunteer Movement	205
Ting, Miss Shu-Ching, B.A., SOME MODERN ASPECTS OF THE YOUNG WOMEN'S CHRISTIAN ASSOCIATION IN CHINA. General Secretary, National committee Y. W. C. A. of China, Shanghai	167
Townsend, Miss Geraldine, A.B., (1919) THE EPWORTH LEAGUE. M. E. Secretary, Epworth League for China, Shanghai ...	198
Tsien, Mr. D. Y., B A., YANGTZEPOO AND OTHER COMMUNITY CENTERS. S. B. C. General Director of Yangtzepoo Social Center, Shanghai	422
Tsu, Dr. Y. Y., CHINESE STUDENTS ABROAD. A. C. M. Formerly professor of St. John's University, now General Secretary of the Chinese Students' Christian Association in North America	343
Twiss, George R., (1922) SCIENCE EDUCATION IN CHINA. Director of Science Education, Chinese National Association for the Advancement of Education, Peking	283

	PAGE
Wei, Francis C. M., THE PRESENT STATUS OF CONFUCIANIANISM. Chung Hua Sheng Kung Hui, Professor, Boone University, Wuclung	67
Woo, Dr. S. M., PHYSICAL CONDITION OF STUDENTS IN MISSION SCHOOLS. P. N. Associate Director, Council on Health Education, Shanghai	367
Yard, James Maxon, B.A., B.D., (1910) RECENT CHANGES IN MISSION ORGANIZATION. THE METHODIST CENTENARY MOVEMENT. M. E. M. General Secretary, Executive Board of Methodist Missions in Eastern Asia, Shanghai	247, 257
Yen, J. C., THE POPULAR EDUCATION MOVEMENT. Secretary, National Popular Education Movement, Y. M. C. A., China... ..	309
Yu, T'ang Lin, A.M. (Harvard), Ph.D. (Leipzig, Germany), THE MOVEMENT FOR AN ALPHABET AND FOR THE SIMPLIFICATION OF THE CHARACTERS. Professor of English and Comparative Phonetics, National University, Peking	318
Yui, Mr. David Z. T., B.A., PRESENT TENDENCIES IN THE CHINESE Y. M. C. A. Chung Hua Sheng Kung Hui. General Secretary National Committee of Y. M. C. A.'s of China	158
Zung, Miss Wei Tsung, PRESENT INDUSTRIAL OPPORTUNITY BEFORE THE CHURCH. Secretary, Industrial Department, National Committee Y. W. C. A., Shanghai	388

PART I

CHINA TO-DAY

CHAPTER I

PAST AND FUTURE USE OF BOXER INDEMNITY FUNDS

Carroll B. Malone

The Boxer Indemnity was exacted from China by the Powers in 1901 to cover their actual losses due to the Boxer Uprising. Chinese Statesmen seemed to be shocked by the aggregate of the claims which reached a total of 450,000,000 taels. This was then calculated at the current rate of exchange in the gold currency of each country and according to the Protocol of September 7, 1901, it constituted a gold debt bearing interest at 4% and to be paid in full during 39 years ending in 1940.

The table below shows the amount (in round numbers) due each country calculated in gold dollars at the rate of .742.

Russia... ..G\$96,735,000	BelgiumG\$5,285,000
Germany , 66,832,000	Austria-Hungary ,, 2,970,000
France , 52,591,000	Netherlands , 580,000
Great Britain... , 37,560,000	Spain , 100,000
Japan , 25,816,000	Portugal..... , 68,000
United States... , 24,440,000	International..... , 157,000
Italy , 19,749,000	
Total overG\$333,000,000	

In 1901 John Hay told Sir Chen-Tung Liang Cheng, the Chinese minister in Washington that he would bring to the attention of President Roosevelt the question of remitting to China a portion of the Boxer Indemnity due to the United States. President Roosevelt agreed to the plan but

Remittance of
American
Share

wanted to be sure that China would really use the money for the benefit of the people.

The Chinese minister wrote to his home government recommending that they tell the American Government that the money, if returned, would be used for education, as that would meet the American idea of the benefit of the people and would help in the negotiations. The powerful viceroy, Yuan Shih-kai, recommended that the money be first used to develop railways and mines and that the profits from these be used for education.

In 1905 Dr. Jeremiah W. Jenks, who had recently returned from investigating the currency system of China, talked with President Roosevelt about the possibility of using a part of this fund for currency reform in China and for the adoption of a gold standard, and part for education.

In 1906 Dr. Arthur H. Smith had an interview with President Roosevelt in which he urged on the President the advisability of making arrangements for the return of the surplus indemnity to China whereby China would use it for education instead of warships, as she might do otherwise. President Roosevelt later said that the return of the indemnity was largely a result of this conversation with Dr. Smith.

In 1907 the Chinese Minister was notified that the President would recommend to the next congress that the surplus of the Boxer Indemnity over and above the actual cost of the military and naval expeditions and the amounts paid out to private citizens and corporations, should be remitted to China. Congress accordingly passed a joint resolution dated May 7, 1908, authorizing the President to remit to China "at such times and in such manner as he shall deem just" the amount of G\$10,785,286 and interest at 4%. The Congressional resolution thus left the President free to make what arrangements he would with the Chinese Government.

No formal conditions were attached to the return of the money to China. The Chinese diplomats were well aware of the ideas of the American Government. Very graciously they expressed their gratitude and their desire to send students to the United States. They soon pre-

**Manner and
Amounts of
American
Remission**

sented a plan so satisfactory to the American Minister, Mr. Rockhill, in Peking that he recommended that the remission of the Indemnity begin at once, as was done in January, 1909.

The following table shows (1) the annual amounts due to the United States according to the Protocol of 1901, (2) the amount retained by the United States, and (3) the amount being remitted annually to China, by the President's order of December 28, 1908.

<i>Years</i>	(1) <i>Due from China to the U. S.</i>	(2) <i>Retained by the U. S.</i>	(3) <i>Remitted to China</i>
1909-10	\$1,022,683	\$539,588	\$ 483,094
1911-14	1,080,787	„	541,198
1915	1,264,582	„	724,993
1916-31	1,329,784	„	790,196
1932-39	1,919,967	„	1,380,378
1940	1,932,374	„	
Deficit	3,407		

The United States kept \$13,655,492 but of this amount: \$2,000,000 was held pending the settlement of certain claims in the Court of Claims. Of this amount over \$1,100,000 was returned to China in six instalments in the years 1914-1917. This makes a total of \$11,960,000 plus the interest, which the United States is remitting to China during the years 1909-1940.

The plan submitted by the Board of Foreign Affairs for the use of the remitted indemnity provided for sending to the United States a hundred students annually for four years, after which fifty should be sent each year. Tsing Hua College was established to prepare the selected students to enter American colleges and universities. Its authorities are responsible to the Board of Foreign Affairs, and have charge also of the students studying in America, of the granting of scholarships to girls and of fellowships to graduates of other institutions.

Of the additional remission made in the years 1914-1917, \$100,000 was given to the Chinese Social and Political

Science Association for its Library. The rest, over \$1,000,000, went to Tsing Hua College and was used for the splendid buildings which have been erected there.

A certain part of the annual remittances is being held in an Endowment Fund, of which the trustees are the Chinese Minister of Foreign Affairs, the Vice-minister, and the American Minister in Peking. It is believed that by 1940, when the remissions cease, there will be in the Endowment Fund enough money to keep the institution on the interest alone.

It is still much too early to judge of the full success of the plan as most of the returned students are still young. Plans to open the scholarships to graduates of other colleges beside Tsing Hua and to provide for sending more mature and experienced students are under consideration.

Cancellations and Postponements Due to the Great War When China declared war against Germany and Austria in 1917 payments on the German Austrian shares of the Boxer Indemnity ceased entirely, and by the treaties which ended the war China was relieved of all further payments to these countries.

In 1917 arrangements were made with the British, American, French, Italian, Japanese, Belgian, and Portuguese Governments to postpone payments on their shares for five years, thereby extending the date of the expiration of the payments due to those countries from 1940 to 1945.

Russia agreed to the suspension of only one-third of her share, but all payments to Russia were suspended in July, 1920, because there was no central Russian Government recognized by China. Although this deferred Russian share is being held in trust by the Chinese Government for the Russian Government, it was used as security for a domestic loan in 1922.

In October, 1922, after the cancellation of the German and Austrian shares, the remission of a part of the American share, and the postponement of payments on several other shares, the amounts still due to the Powers as calculated in pounds sterling by the Ministry of Finance were as follows:

Russian Gov't	£27,019,467	Belgian Gov't	£1,874,940
French „	„ 15,663,261	Dutch „	„ 141,981
British „	„ 11,186,547	Spanish „	„ 24,565
Japanese „	„ 7,688,867	Portuguese „	„ 20,486
Italian „	„ 5,882,046	Swedish „	„ 11,405
American „	„ 2,517,959		

The *greater* part of this seems likely to be remitted or used for purposes deemed beneficial to China.

The United States is the only country which has voluntarily remitted a part of the Boxer Indemnity to China, and the remission of the remainder of the American share has been proposed in Congress more than once. Japan, France, Great Britain and Russia also have plans for using the payments still due them for the *benefit* of the Chinese people.

The Japanese Government has definitely decided to use future Boxer Indemnity payments for the advancement of Chinese civilization. The money is not to be returned for China to use herself, but its expenditure has been entrusted to a Japanese Government Bureau. It will amount to about 2½ million yen per year. The details of the plan have not yet been announced, but at present some support from this fund is being given to Japanese hospitals in Tsinanfu and Tsingtao.

The French Government has made a conditional offer to the Chinese Government to use the proceeds of all future Boxer Indemnity payments for two purposes, which will be of mutual benefit to both countries. The first purpose is to satisfy the Far Eastern creditors of the Banque Industrielle de Chine by giving them 5% bonds payable in gold dollars in exchange for the bonds which are being offered them by the defunct bank. The second purpose is the benefit of Sino-French educational or charitable enterprises to be agreed upon each year by the Chinese and French Governments. The conditions of the offer are that the creditors of the Banque Industrielle shall agree to accept the gold bonds of the French Government in place of the franc bonds of the bank, and that the Chinese Government shall agree to pay the subsequent instalments of the Boxer Indemnity in gold francs in

conformity with the Protocol of 1901. The question whether China must pay in gold or may pay in paper francs at the current rates of exchange is still unsettled at the present writing.

The British Government has also informed the Chinese Government that it has decided in principle that further payments on the Boxer Indemnity should be used for purposes mutually beneficial to both China and Great Britain. The exact method of so using the money has not yet been decided upon.

The latest offer is that made by the representative of the Soviet Government, which has not yet been officially recognized, in answer to an appeal from the representatives of the Eight National Institutions of Higher Learning in Peking. The Soviet representative speaks of the Boxer Indemnity as having been forced by criminal violence on the Chinese people by the Tsarist Government in 1901, refers to the offer made in 1919 to give up the Boxer Indemnity, protests against the use of the money by the Chinese Government for diplomatic or any other purposes until there shall be some agreement between the two governments in the matter, but, in view of the danger threatening the Peking Institutions, he offers to allow China to use the money for their relief immediately, even before the formal conference between China and the Soviet Government.

*Special Plans
for the Future* Miss M. E. Wood, Librarian, Boone University, has a plan for the allotment of a portion of the next remission which the United States may make for the establishment of reference libraries in some of the chief cities of China.

There has been some discussion of the advisability of pooling the funds remitted by the various countries for the sake of the larger educational needs of China, if the various nations concerned could agree.

CHAPTER II

THE BANDIT SITUATION AND CHRISTIAN WORK

Frederick G. Onley

A leading article in a Chinese newspaper *Bandit Types* describes the prevalence of the bandits in China as "thick as hair". The term bandit, however, is loosely applied to what the Chinese call "Hsiao T'u-fei" (Small bandits) and "Ta T'u-fei" (Big bandits). The big bandits are of the type of the famous "White Wolf" who was the scourge of Honan some years ago. To this type belong the authors of the Lincheng outrage on the "Blue Express" in May 1923, and Lao Yang Ren (Old Foreigner) in Honan and Hupeh during 1922 and 1923. They loot, burn cities and take captives, and if these be foreigners, expect a large ransom, incorporation into the army for the rank and file, and high promotion for leaders.

The Small bandits or local T'u-fei are very widely distributed small groups of bandits and highwaymen of varied origin. Many are survivals of the movement which opposed the military and political policy of Yuan Shih-kai, who since they did not receive willing support from the democracy, began to levy forced contributions from well-to-do farmers, sometimes up to one half of a man's capital. Hence these bands became known as "Shang K'uan ti" (contribution raisers) or more euphemistically "K'uan Hsiensheng" (Mr. Sum of Money). These bands now are not political to any marked extent, but are recruited from the class of respectable-farmer-by-day, who turns bandit at night, and by deserters from local militia and from unpaid or defeated units of the army. These bands are from ten to fifty in number in the case of the small ones, and from two hundred to five hundred in the case of the larger bands, but such tend to become united as "Big bandits". Small bandits seem to be endemic in most regions, although there are some patches of

territory in bandit-ridden provinces where the resistance of the inhabitants has secured freedom for the last ten years.

Bandits in Honan

Not since the raids of White Wolf has Honan known such terror from bandits as was experienced in the autumn of 1922. The progress of the band was swift and terrible, and soon a long list of looted cities appeared, and the new feature was the capture of numbers of missionaries including women and children. In some cases the wives of missionaries were allowed to go free, perhaps in order to raise money for ransom. A typical experience was that of Mr. Ledgard of the C. I. M. in Honan who was forced to leave his looted home and wife and child, and was carried off for thirteen days until he effected his escape from stragglers of the band. During this time he saw five large cities taken and almost entirely burnt, and hundreds of villages and large market towns treated in the same way. Other missionaries suffered similarly, and in some cases children were captured and separated from their parents in different sections of the same band. The leader of these bandits was a man named Chang, whose bandit title was "Old Foreigner" (Lao Yang Ren). After this Honan outbreak, the big bandits in the company of Lao Yang Ren were paid ransoms, received into the army, supplied with arms, and ammunition, and uniforms, and their leader made a general. The following year, this same bandit broke out again, and surpassed his previous records for ruthlessness in the capture of cities in northwest Hupeh, and southwest Honan. It would be interesting to discover the cause of this further outbreak, whether due to arrears of pay, the prospect of disbandment, or of a tardy punishment.

The Big bandits subsided for a while, and the spring of 1923 passed with few alarms, although the city of Shang Tsai, from which Mr. Ledgard was taken in the previous Autumn, was again threatened by a band 2,000 strong, but the walls were manned by the people, and the band passed by. The Small bandits, however, were as active as ever, and in many parts of Hupeh, it was a common thing to hear of the ill paid bands of local militia turning bandit

and looting small towns. The same conditions were found in Shensi, Fukien, Shantung, Szechuan, Manchuria, Human, Anhui, etc. The provinces of Shansi, and Kiangsi were reported quiet.

On May 6th, 1923, the "Blue Express" Lincheng was wrecked by Shantung bandits at Lincheng. The date was that on which the Chinese government, after postponing it for a year, announced that it would be ready for an investigation as to its fitness for the abolition of extra-territoriality in accordance with the decisions of the Washington Conference. Twenty-four foreigners and 200 Chinese were captured and one foreigner was killed. All suffered great discomfort and hardship, most of the foreigners being unused to Chinese food and conditions outside a treaty port.

The ladies of the party were released before the men, the majority of whom spent five weeks in the bandit stronghold of Paotzuku. The Diplomatic Corps made strong representations to the Chinese government and practically dictated the means to be used to secure the release of the captives unharmed. The result was that the bandits were paid a large ransom, uniforms supplied, the men incorporated into the regular army, and the leader promoted to high rank. This action seems to have fixed the normal method of dealing with bandits who capture foreigners. Later activities of bandits seem to show that the mishandling of the Lincheng affair, according to the almost unanimous opinion of Chinese and foreigners, has been largely responsible for the subsequent efforts to capture foreigners in order to achieve a similar result.

In June a Honan bandit named Liu, an ex-lieutenant, raided northern Hupeh, starting from the *hsien* of Tungpeh in Honan. He penetrated as far as Yingcheng *hsien*, and captured Fr. Melotto, an Italian priest, and threatened Tsaoshih, but turned and returned to Honan after looting an out-station of Tsaoshih. Following this episode, the Chinese officials advised the missionaries at Tsaoshih, which is an unwalled town, to remove temporarily to the nearest walled city, or to take a holiday at Kuling earlier

Foreigners
Captured-1923

than usual. The missionaries of the London Mission complied and followed their families to Kuling, but the Irish Roman Catholic priests refused to leave, and relied on the soldiers sent to protect the town.

On August 16th, the same band which held Fr. Melotto descended again to the same region from Honan, and burnt Tsaoyang and Sungho on their way to Tsaoshih. On arrival at Tsaoshih, the first question asked was "Where are the foreigners? Lead us to them". This seems to have been the prime motive of the attack. The R. C. priest barely escaped by crossing the river on a door, and the premises of the Roman Catholics and of the London Mission were looted and burned, including residences and a part of the hospital. The Chinese doctor and assistants were taken captive, also a large number of men and women, old and young from the town, which was two-fifths burned.

Fr. Melotto refused to be ransomed by money, and when the soldiers sent to secure the release of the old priest got to close quarters with the brigands two and a half months after his capture, the leader of the band murdered the priest with his own hand and fled, and has not been caught.

On August 23rd, two C.M.S. missionaries, Messrs. Watt and Whiteside, were murdered by bandits at short range near Mienchow, Szechuan. At the end of the same month an engineer was captured by bandits in Yunnan. At this time there were also attacks on a Roman Catholic church near Laohokow in N. W. Hupeh, and also on a R. C. station in Chihli. Mienchih, 80 miles from Kaifengfu, Honan, was attacked. Early in September a French mission station on the borders of Fukien and Kuangtung was attacked by rebel troops (also termed by Chinese T'u Fei) the priest beaten, and the furniture of church and school smashed.

The end of September was marked by the capture on the 22nd of two lady missionaries of the C.I.M. at the sack of Sihua in Honan by a band of Shantung bandits under Fan Ming Hsin. They suffered great indignities and terrible discomforts as they were dragged over the roughest hill country for five weeks, before they were

released by the hot pursuit of soldiers under the personal direction of the Military Governor of the province.

In October a German missionary was captured in Hunan, and at the end of December was unreleased. November saw the capture of a R.C. Bishop and a priest in Shantung, the former was set free, but the latter was released by a trick. The soldiers pretended to join the bandits, and on entering their camp, opened fire on them. This followed an appeal by the Bishop in Peking to the government to use peaceful methods in securing the release of Fr. Frederick, who was reported to have baptised some of the bandits before his capture, and to have promised to try to secure their enrollment in the army.

Mr. E. W. Schmalzried, an American missionary, was captured on the western border of Hunan on November 21st. At the end of this month the notorious bandit of Honan, Lao Yang Ren, broke out of the army with his band of some thousands and crossed into N.W. Hupeh and attempted to attack Laohokow. He then went to Likuanchiao, over the Honan border and after sacking the town, put most of the males to death under conditions of the utmost barbarity. Some were tied up, soaked in kerosene and then burned. It is estimated that of the known persons, apart from floating population, 4,000 were killed. An unsuccessful attack on Yunyangfu, lasting three days and nights was beaten off and the next city of Yuinhsi hsien was treated in the same fashion as Likuanchiao.

Reports from South Hunan, West Hunan, and North Hupeh indicate that during December the Small bandits were active over wide areas. In many places church services were interrupted, and Christians molested along with the rest of their fellowcountrymen. They are bearing the "cross of perpetual insecurity".

Causes of Banditry To say that banditry is due to unpaid soldiery, is to begin at the middle of the chain. The soldiers are enlisted from those who are suffering from economic pressure in the poorer parts of China. The pay of a soldier is little inducement to enlist, and when this is withheld, the inducement to

become a bandit is great. The core of the bandit bands is formed of ex-soldiers. It is a common saying that the soldier of to-day is the bandit of to-morrow, and the bandit of this year is the soldier of next. The typically Chinese method of receiving bandits into the army is not so strange as appears. The men to become bandits must have some grievance. If an ex-soldier, it is owing to the smallness of the pay or its arrears over many months; if a farm labourer, it is the grinding oppression of the landlords in some parts of the country that drives them to desperation. In some parts of Hupeh, a rich province, fields lie untilled owing to the fact that many labourers have taken to the more profitable occupation of bandit. In many areas the local town elders employ poor men as militiamen at a monthly remuneration of \$4.00 Mex. These men readily accept bribes from the bandits to sell ammunition or to go over to the bandits with their guns. In some cases the bandits, on getting the guns have turned the deserters adrift. A careful investigation of the Lincheng bandit area shows that economic pressure was the chief factor in producing banditry in that area. This conclusion is endorsed by foreign and Chinese captives, and is published by some of those who shared in the negotiations for the release at Lincheng. In some cases, an existing band is joined by those who fear vengeance from enemies, and some use bandits to exact retribution for past injuries. In some parts of Szechuan the "Muddy Water members" of a Secret Society known as The Long-robbed Brotherhood are the Small bandits and practically control the whole of society. Even officials belong to the higher orders of the Brotherhood.

**Effect on the
Church and
Christian work**

In some cases Christians have been tempted to get into touch with bandits in order to secure immunity from attack. Some have acted as go-betweens in negotiating ransoms or the purchase of immunity. In one case known to the writer, an agent of the Independent Chinese Church with headquarters in Shanghai, has urged farmers to join this movement in order to secure immunity from attack. Bogus bandit visits have been organised to prove the statements, upon which subscriptions to the church have

been readily forthcoming. This became so notorious that the magistrate had to suppress the agents. Some testimony speaks of a moral decline of converts in bandit areas, but the majority speak of a strengthening of faith and fortitude owing to answers to prayer for the release of friends. One case is mentioned of the bandits leading a captive blindfolded back to his own farm and ordering the man not to remove the bandage until some time after, when he discovered himself at home. His fellow Christians had been engaged in unceasing prayer for his release.

Much mission and church property has been destroyed, and many Christians have suffered from captivity and some have lost their lives. In some cases, there has been a noticeable keenness to urge the missionary to claim compensation, and when this has been refused, some bitterness has been caused, but this has been modified when missionaries have refrained from claiming compensation for personal and mission losses. The opinion of Chinese outside the church has been that this is a sign of weakness, and some of the more ignorant have turned from the evangelistic appeal with scorn in consequence. This is probably due to a belief in the church as a help in litigation, and a survival from past methods of propaganda. On a full explanation of the reasons being given, the outsiders and church members have appreciated the point of view that inasmuch as indemnities in most cases come from added taxes placed on local people (who in most cases have themselves suffered from bandits with no hope of redress), it is a generous and Christian act to forego any claim on the Chinese government. The attitude of the Consular officials and business community generally is that indemnities should be claimed in order to force the government to protect the lives and property of foreigners.

On the part of the missionary community, opinion is divided. In the case of one mission, the L. M. S., the experience of the harm done to the evangelistic work by the acceptance of indemnities in 1900, has led them to refuse unanimously any claim for destruction of property at Tsaoshih. At Kuling in the summer of 1923 a resolution

at a meeting of missionaries looking to the relinquishment of the use of force and the exercise of extraterritorial rights found a majority against it, but it is said more might have been in favour had the wording been different.

The unrest of the country has much hindered the itineration of foreigners in most provinces, and many missionaries have been driven out of their stations for a time. The sale of Scriptures in the countryside has been reduced, and that of tracts and Christian books been much lower than normal. This is held to be a sure index of the state of disturbance. On the other hand, the experience of some has been that an evangelistic appeal based on the topic of "How to save the country" has been more than usually successful, especially where bandits have swept over the country.

Whilst most parts of the country have been affected by the bandit scourge, yet only a small fraction of the missionary body, say two percent, has suffered losses to personal or mission property, and still fewer have been captured by bandits, although many have been in danger of capture, or robbery. The chief danger zone has been the province of Honan, where, perhaps the strongest military forces of China are kept.

Towards a Cure The strength of the bandits is the possession of firearms. Where bandits have run out of *ammunition*, the peasants have been able easily to destroy them. Whilst a considerable amount of arms smuggling by foreigners has been brought to light, and probably much more is undiscovered, yet the chief source of supply of ammunition is the government arsenals of China, and the distributors of this to the bandits can be none other than the soldiers who sell it to supply the arrears of their pay. The bandits offer high prices, and sometimes pay with loot. In some cases soldiers have revolted when the usual supply of ammunition was curtailed.

It would seem that none of the soldiers of the army of the "Christian general", Feng Yu Hsiang, have turned bandit. They have been taught trades. That is one Christian solution. The reduction of the numbers of

soldiers, following instruction in improved agriculture and trades, together with increased attention on the part of the Christian movement to the problem of economic improvement of rural life, will gradually eliminate the causes of the present unrest. The full Christian programme is required as an amplification of the Christian Message to meet the whole need of the whole nation.

CHAPTER III

SOCIALISTIC TENDENCIES

D. K. Liets

Influence of
Socialistic
Teachings

Many Chinese students have recently been influenced by socialistic teachings. Some have even inclined toward bolshevism. In Peking, the students of the National University are much interested in the study of such questions, and have arranged for many special lectures on them. Mr. Chen Tu-hsiu, a former professor of the University, is a leading advocate of socialism. He was editor and publisher of the monthly magazine "La Jeunesse," which started some discussion of this topic, but his later publication—a Shanghai weekly called the Guide—is out and out socialistic (both publications are in the Chinese language). In fact, he attracted so much public attention that the Government issued an order for his arrest as a bolshevist. A socialistic publication was suppressed in Peking not long ago.

It is hard to tell whether the students are really converted to socialistic doctrines, or merely infatuated by them because they are new. There has been a tendency in the school population of China to embrace any and every form of innovation, just as women take to new fashions and fads. If *that is true*, they will quickly forget socialism when still newer ideas come to take its place. But, however that may be, at least a small number of them must have taken the matter very seriously, and advocated socialism with strong convictions that it is a good thing for this country to adopt. Exactly what percentage of the students of the whole country is among the real advocates, and how many of them are in favor of each of the many forms of socialism, it is very difficult to tell. It may be stated in a general way that the two forms of socialism most discussed in China at present are Marxian socialism and Russian bolshevism.

There were probably more strikes in the last two or three years than in all the ten preceding years. Labor has awakened to its unsatisfactory conditions, and is demanding higher wages, shorter hours and so forth. Many labor unions have been formed, especially among the seamen, the cotton mill hands and the railway workmen. Professor C. Yang, of South-Eastern University, Nanking, has compiled some interesting statistics about strikes during the last quarter of 1922, which are given in the following table. But strikes alone do not prove that socialism is spreading among the laborers. On the whole, Chinese laborers have not yet reached the stage of disputing about the inequality of wealth distribution and such broader and deeper economic problems. Their strikes having been concerned with problems of local and individual trades. Nevertheless, cooperation between the students and the laborers may some day make socialism a real force in this country.

Strikes during September-December, 1922

	<i>No. of strikes</i>	<i>Number of Strikers</i>
Kiangsu	19	53,180
Chihli	4	38,000
Kiangsi	1	25,000
Hupeh	4	11,500
Shansi	2	7,500
Hunan	7	5,700
Shantung	1	4,008,600
Hongkong	2	
Chekiang	1	100

Coöperative societies are being organized in many parts of the country. Fengtien has many savings societies which offer more or less easy facilities for coöperative credit. The China International Famine Relief Committee is trying to organize rural credit societies at Siangho (香河), Tangshan (唐山), Tinghsien (定縣) (all in Chihli) for experimental purposes. Coöperative book stores have also been established by students.

Early Chinese
Socialists

If we turn backwards and study the economic thought of the nation before Western socialism was ever heard of, we shall find certain doctrines and ideas which, though not known by this name, are nevertheless socialistic in nature. In certain respects, the Chinese people practise these doctrines very consistently, and some of them have produced good results, although these are hardly noticed by modern advocates of socialism. The earliest teacher of such doctrines, strange to say, was a patriarch who ruled the country even before the days of Hwangti.

Shennung (神農), who lived more than twenty-five centuries before Christ, was the first socialist in China. He may indeed be considered the first in the world. According to his teaching, nobody should consume any food which he did not himself produce. This doctrine applied more particularly to agricultural products. It was his ideal that every man should become a farmer. As late as the fifth century B.C. some of his followers — Hsu Hsin, Chen Hsiang and Chen Hsin — still upheld this doctrine and severely criticized the feudal lords for not attending personally to the cultivation of the land and the spinning and weaving of the fabrics which they wore. This, they contended, was most unjust, as it meant the sharing of products by people who did not produce themselves. A long discussion between Mencius and these socialists is recorded in the book of sayings of the former, by which the Confucian sage convinced Chen Hsiang of the necessity of division of labor, the exchange of products, and the value of immaterial services rendered by the feudal lords. How many more people preached Shennung's doctrine after this is not definitely known, but this socialistic idea of "no farming, no food" has had much influence on the Chinese mind.

Farm Laborers
Respected

Through tradition which had its origin at about the same time as Shennung, the Chinese people have been taught to have special respect for farm labor. This respect may not be outwardly shown to the farmers, but it is entertained toward agricultural labor in the abstract. Even very rich men, especially in the country districts, would feel a sense

of guilt, sometimes tantamount to sacrilege, if farm products were wasted by their children or their servants. It is a common saying in Kiangsu, where rice is produced in abundance, that each grain of that cereal has undergone seventy-two processes of labor, and is for that reason far more valuable than its market price indicates. Household servants in the south — sometimes even the masters and mistresses — always do their best to avoid wasting one grain of rice or one ounce of wheat flour, although meat and fish may be generously thrown into the garbage pan. And this holds true even in such cities as Shanghai and Soochow, where the people are accustomed to extravagant habits in other respects.

Another evidence of this respect was the age-old practice of the emperors to cut the sod personally with a plough at the beginning of every new year, and of the empress to attend to the silkworms for a short while. It was to show the common people that the task of producing food and clothing is an important one, and should be participated in by every body in the country.

Production and Consumption Under the Han dynasty, a great scholar, Chia Yi (賈誼) made the following remark to the emperor: "If one man in the country does not plough, somebody is going to suffer from hunger, if one woman in the country does not weave, somebody is going to suffer from cold." In addition he pointed out that production must proceed faster than consumption in order that all people might be adequately supplied. His ideal was that everybody must produce, and nobody consume a share larger than the average. In particular, he wanted the emperor to decrease consumption. This does not sound like a socialistic doctrine, but it is a truism, which, if universally practised, will to a great extent alleviate the kind of suffering which has caused the socialists to condemn the present economic organization.

Another doctrine having a similar effect on economic life is that of Laotzu. "If you do not find anything desirable, you have no craving to disturb your peace of mind. If rare objects are not highly valued, there will be no thief or robber." This goes a step further than Chia Yi's doctrine, and instead of controlling consumption, the

desire itself is to be held in check. As economics teaches us, both utility and want have a psychological basis. If one does away with desire, there will be no want and no dissatisfaction. If there is no desire for distinction, much useful labor would not have been wasted on the mining of diamonds and other precious jewels. The followers of Hwangti and Laotzu do not pretend to say that food and clothing are not necessary, but they mourn the waste of human energy for the satisfaction of wants which could be done away with.

**Unequal
Distribution of
Wealth**

“In the palace there was a super-abundance of food and delicacies; in the country people died of hunger,” was a poet’s criticism of certain uncharitable rulers. It is a picture of unequal distribution of wealth. Chinese historians and men of letters always condemn extravagant rulers, and all rich people who waste the products of labor, especially farm labor, share the same criticism. In fact, there is a general opinion against waste and extravagance, and even luxuries are usually condemned. Farming and weaving are considered the foundation of economic society; other industries and trades are of minor importance. Both the producers and the consumers of luxuries are not held in respect.

**Inequality of
Consumption**

The Chinese attack inequality of consumption more than that of distribution. One man may receive a larger share of the society’s products than another, because he is more able to make use of it for the good of society, but he is not entitled by any divine right to consume more than others. In respect of economic wants, all human beings are equal. Approximately speaking, what is enough to feed and clothe one man is enough to feed and clothe another under the same climatic conditions, and no one can ever argue that a rich man will die when he has no bird’s nest for one meal, while a poor laborer may live without the coarsest food for three days! God has made all men equal in such respects.

**Practical
Socialism**

There is also a good deal of practical socialism in China in connection with the family and the industrial guild. The “family” in China is far more inclusive than in Western

countries, so much so that the income of one well-off member is practically the common property of all members of a large family. He has to support his third or fourth cousins, and in some families a piece of land, known as Yi-chuang (義莊), is actually kept as common property for the support of all unfortunate relatives. The guild, too, provides for its members who are sick, and for their families when they die. The advocates of guild socialism are making a study of this Chinese institution with a view to utilizing it as the foundation of a new economic system.

The above is a brief account of socialistic tendencies in this country. How far China will go in the direction of Western socialism, no one can tell, but judging from the mental attitude of the whole nation, it is very unlikely that it will be stamped by the doctrines of communism or bolshevism.

CHAPTER IV

MILITARISM

Grover Clark

The Cause Though there is no enemy threatening her borders, though there is no real cause for civil war, though her people are naturally industrious and peaceful, China to-day has more soldiers in her midst than any other nation — and this in spite of the fact that the upkeep of the hordes of “armed coolies” draws off so large a part of the country’s financial resources that almost nothing is left to pay the legitimate foreign and domestic debts of China or to keep the most necessary administrative machinery running, to say nothing of there being no money for large constructive enterprises such as railway building or for the adequate maintenance and development of education.

Nor has this situation come about through any active desire of the great majority of the people of China. It is the result of the passive yielding of the people and the squabbling among various unscrupulous and purely selfish individuals to secure power and the perquisites of office. A few of the military leaders have perhaps been sincere in their desire to help China, even though they felt that such help could best be rendered by getting for themselves an increasing share of control in the nation’s affairs. Most of them, however, have thought only of personal aggrandizement and enrichment, and have hesitated at nothing — from cold-blooded poisoning of their superiors or associates down — to realize their desire.

Relation to Bandits Moreover, the unscrupulous struggles for power of these militarists have done more than load China down with a worse than useless burden of soldiers — i.e. of men nominally in recognized organizations and under responsible commands.

A large part of the bandits with whom the country is at present infested are former soldiers who, chiefly through the defeat of their commanders, have been expelled from the army. Having become used to the easy life of the soldier — who, in China, has everything provided for him in the way of food and housing without being called on, except in extremely rare cases, to do any fighting or actual work — many of these men were unwilling to return to their homes and the life of peasant farmers from which most of them had come originally. Therefore they turned bandits; and not infrequently they were allowed surreptitiously to take their arms and ammunition with them on leaving the army.

Sun Mei-yao's bandit gang, which was responsible for the Lincheng Incident, for example, was composed largely of ex-soldiers who had drifted into banditry in this way. And Lao Yang-jen's gang which has been terrorizing Honan for several years is made up almost entirely of men from the defeated armies of one or another of the former Tschun of that province.

The militarists also are responsible for the continuance of banditry in another way. Few of the military men on top to-day are sure of being able to keep their positions for any length of time; they may at any time have to fight to retain their offices; in that fighting it would be an advantage to be able to call on the support of fairly large bodies of ex-soldier bandits; in case of defeat — and this the common soldiers feel especially — it would be well to have the door left reasonably wide open for joining the bandits.

In many cases, too, the men at present on top in one way or another owe their positions partly at least to the help of these so-called bandits.

And besides all this, some of the provincial militarists are distinctly not on good terms with the Peking Government. But if foreigners suffer from the bandits it is the Peking Government, not the provincial leader, which must bear the anger and listen to the protests of the foreign Powers.

These are some of the reasons why many of the military leaders show so little energy in suppressing the bandits in

the territory under their control. In some of the provinces — such as Shensi and Szechwan — there is no one man actually in sufficient authority to enforce his will throughout the whole district. But in many of the others where either the bandits or the soldiers — and the soldiers not seldom do as much damage to the farmers as the bandits, if not more — apparently are left with practically no check on their depredations, the responsibility must lie directly on the military chief. Such is the case in Honan, Hupeh, Chihli, and Shantung, for example, where the authority of Tsao Kun and Wu Pei-fu has been substantially undisputed for some years. And yet perhaps the worst bandit area to-day is Honan, in which Wu Pei-fu's headquarters are located — and one of the principal winter rendezvous of the bandits is reported to be within a short distance of those very headquarters.

Even most of the military men themselves recognize that the hordes of soldiers and ex-soldiers create a grave problem in China; most of the civilian leaders, and some of the militarists, would agree that they are perhaps the most serious obstacle in the way of financial, economic and political order.

Exact figures of the number of soldiers duly enrolled are impossible to obtain, but semi-official and reliable estimates put the total at between a million and a half and two million. A Chinese army division contains, at full strength, 12,000 men. On this basis there are enough men under arms in China to form between 125 and 150 divisions. The monthly expense of maintaining a division is approximately \$450,000. Assuming that all the men under arms were regularly paid and the normal peace-time expenses of this "army" were met in full, therefore, between \$56,250,000 and \$67,500,000 *monthly* would be required.

But far short of this amount is available, with the result that the private soldiers are chronically behind in their pay and, in order to keep them pacified, the leaders are forced to get what money they can wherever they can. The consequence is that, for one thing, all sorts of special taxes and levies are imposed on the people in the districts

where the soldiers are quartered. In addition to this, as the amounts due their men have fallen more and more in arrears, there has been a growing inclination on the part of the militarists to take for themselves the receipts from various of the regular Government undertakings such as the railways, the salt monopoly administration and the wine and tobacco monopoly administration.

The diversion of funds from the railways — the Peking-Hankow line has suffered particularly in this respect — has meant that little or nothing is left even for repairs and upkeep of the rolling stock or the road bed, not to mention improvements.

The seizures by the provincial authorities of the salt and wine and tobacco receipts — this has been done most conspicuously in Manchuria, though some of the southern provinces also have held up the payments to Peking from these sources — have been in such amounts to jeopardize the various foreign and domestic debts secured on these revenues.

And even what money has found its way past the provincial leaders to Peking, or has come in from such sources as the Peking octroi, has been drawn on by the militarists to such an extent that the administration has for many months been forced to live on borrowed money almost exclusively. It has been able to provide for some of these debts by putting them under foreign supervision in the Consolidated Loan Service. But in spite of everything that could be done to get security, there are at present in the neighborhood of \$600,000,000 outstanding debts of the Peking Government *for which there is no security except the promise of that bankrupt Government*, besides enough more debts which are secured more or less adequately to bring the total to something over \$2,000,000,000. These figures do not include the amounts due for arrears of pay to civilian officials and soldiers, running probably to over \$500,000,000 more.

Disbandment The mere size of this debt, for a country like China, is no particular cause for comment. The seriousness of the situation arises from the fact that a large part of the debt is due directly or indirectly to the demands of the militarists, that

much of it has been incurred for no constructive purpose, and with no benefit to anyone except a few who grew rich at the public expense and that there seems to be little prospect that in the near future this militaristic drain will be stopped.

There has been, of course, a good deal of talk about disbandment. But though this talk has been going on with particular enthusiasm since the Washington Conference, nothing has been done. Instead, there is no doubt but that there are more—distinctly more—“soldiers” in China to-day than there were two years ago.

There are several reasons for the continued recruiting. Each leader wants to insure his own position as against possible rivals. Therefore he adds to his army on the slightest provocation. Seeing him do this, his rivals add to their armies. So the vicious round goes. Nor is any one of the men at present on top quite willing to start disbanding until after his rivals begin—though they all talk much about how good they think it would be for China to reduce the number of troops. Nor is any one of the leaders strong enough to force the rest to cut down their armies.

And the question also arises of what would be done with the soldiers after they were disbanded. They could not simply be turned loose on the country; this would mean only so many more bandits.

For meeting this problem of the disbanded soldiers various schemes are proposed. One is that they should be encouraged by Government grants of land and temporary financial help to settle in the unoccupied areas of Manchuria and Mongolia. Another is that a loan should be raised for railway and canal construction work, the labor to be performed by ex-soldiers.

But the obstacle in each case—aside from that of getting the militarists to agree to reduce their armies—is the difficulty of financing the undertaking, especially since, in addition to the funds needed after the men are out of the army large amounts would be required to pay even a part of the arrears due them as soldiers.

Merchants and Militarism Altogether, the prospect of putting an end to the curse of militarism in China does not seem very bright. Whichever way one turns, he is almost sure to find some selfish, unscrupulous military leader, backed by a horde of uneducated, armed coolies almost as unscrupulous as himself, at the bottom of the particular evil which needs remedying. And these military men are able to maintain their positions because, by hook or crook, they can get enough money together to keep the men under them satisfied.

Once the sources of revenue were cut off the armed hordes on which they rely would disappear and their power would be gone.

The final control of the finances of the country rests, of course, in the hands of the people of the country, and particularly in the hands of the merchants. They suffer much from the present conditions. Perhaps when conditions get worse and they suffer more they will be ready to take such action as will put an end to the militaristic domination of China's affairs. They could do this simply by refusing to pay taxes or in any other way letting money get into the hands of the authorities. Probably some of the merchants would be killed, in the beginning, in an attempt to force submission. But such murders would stir up a furor of popular protest, and if the merchants stood firm the militarists would very soon capitulate.

There are few signs that any such stand will be taken by the merchants in the near future, however. The chief difficulty is the lack of solidarity among the merchants, and the absence of any readiness to sacrifice for the sake of the country as a whole.

But whatever the reason, the responsibility for the present conditions — military and otherwise — must in the end rest directly on the people of China and specifically on the more intelligent and better educated part of the people who should be the leaders.

The militarists keep going because they can get money. They can get money because the people let them have it. They will not get money when the people stop giving it to them. When they have no money they will be forced to go out of business.

CHAPTER V

CHANGING INDUSTRIAL LIFE

I. SOUTH CHINA

Introduction of Modern Machinery It should be taken for granted that China will adopt, as soon as possible, modern machine industry and the business technique which has formed so conspicuous a feature of occidental civilization during the last century and a half. The economic advantages of capitalistic methods, seen in the multiplication of goods, in the most productive utilization of material resources, and in the benefits of improved transportation and communication facilities, are so obvious that it is certainly a matter of only a very short time before China, like Japan, will pass through an industrial revolution.

Industrialization is inevitable. The urban population may be expected to grow more rapidly than the rural, household industries will give place to factories, the personal relationships of proprietors and workmen in the small shop will become the more impersonal relationships between corporation employers and employees, workmen will be concentrated in industrial areas, class consciousness will develop, and probably a new chapter of the old struggle of capital versus labor will be enacted in China.

Retarded Development of Industrialism in South China Already industrialization has proceeded far in the eastern and central portions of China. In South China, however, the movement has been retarded by the continuance of an uncertain political situation, which has arrested all industrial activities to a greater or less extent. In spite of the wealth and progressiveness of the Cantonese, very few large factories are to be found in the Canton region, although there has been a remarkable increase in the numbers of smaller factories and establishments using light power machinery.

Factories in Canton

Match factories, cotton knitting mills, machine shops, glass factories, rice mills, tanneries, drug and chemical factories, silk filatures, cotton and silk weaving mills, brick factories, and the like — these are the industries which, despite war conditions, are springing up in great numbers in Canton and vicinity. Fuel costs are high, and until the rich coal resources of Kwangtung are made available it is not likely that many large mills, or heavy power factories, similar to those in the Yangtze region or in Japan, will be built. At present, power is generally developed by crude oil or producer gas engines, or by motors using electric currents.

In some of the factories, especially in those devoted to the manufacture of cloth, matches, and chemical products, machinery has been imported from Europe and America. In some cases modern factory buildings have been erected, but probably more frequently the new machinery is installed in old structures poorly adapted for use as factory buildings. Many women and children are employed in these factories, as skill rather than physical strength is required of the operatives.

Labor Organization

A number of fairly strong labor unions have grown up with the beginnings of the new industrialism in South China. Among those who are most effectively organized are machinists, printers, seamen, restaurant workers, barbers, workers in the oil-expressing shops, tobacco cutters, etc. Some of the unions have been able to secure for their members improvements in wages, hours of labor, and working conditions. The strike as an industrial weapon has occasionally been attempted, but with one or two notable exceptions has met with comparatively little success. The resources of the workmen or of their unions are seldom sufficient to sustain a prolonged strike.

Industrial Survey

A committee in Canton under the auspices of the National Christian Council is undertaking a survey of certain industrial conditions in and about the city. The committee is composed of Chinese and foreigners of the various Christian

organizations in the region. It is limiting its field of special survey to the silk industry (particularly the filatures), and to the machine shops and foundries. A general social survey of broader questions will be undertaken in the city at the same time, and it is hoped to use the material gained in a definite campaign for better conditions.

**Christianity
and
Industrialism** It has often been observed that the Christian Church has an extraordinary opportunity in connection with the problem of the industrialization of China. If by its efforts the Church can anticipate the coming of the industrial order in this country, provide those safeguards that will insure to the masses of workers just treatment and fair working conditions, and by its organized effort and the influence of its members humanize industry and foster relationships of brotherhood, coöperation, mutual respect and happiness, it will be a splendid achievement in Christian service rivaling in importance any other activity the Church can undertake. The Church has an opportunity, and indeed a responsibility, in taking the initiative in the intelligent study and solution of the labor problem that should challenge its finest talents, its broadest sympathies, and its most generous efforts.

It would be a great pity if the workman of China should have to engage in a long struggle, as has been the case in western lands, in order to secure for himself the simple privileges of honest wages, reasonable hours, safe and healthful working conditions, and a measure of security in his job. If possible, the factory worker here should be spared the terrible exploitation which European labor suffered. The Church should take the lead in cultivating an aroused and enlightened public opinion and in securing the enactment and enforcement of appropriate labor legislation that will prevent the oppression of the helpless in industry and will relieve industrialism from its more serious mechanizing effects. China should profit from the unlovely experiences of the West and be spared the flagrant evils that have characterized the rise of the factory system. The tremendous material gains from the

use of modern machine methods are apt to eclipse social and human values. To preserve and enlarge these human values in the transition to industrialism is the duty of all Christians and of the Church.

KENNETH DUNCAN.

II. THE WUHAN *

With our restricted perspective we can make but limited and partially accurate estimates of the changes that are taking place all about us. It is impossible for us to perceive changes that must be reckoned by decades and by centuries instead of by hours and by days.

What seems to be a great and lasting change may be only a snag in the river's bed that creates quite a disturbance, until it is either removed or the water rises above its influence, but the river flows on unceasingly. The tool that a workman uses does not necessarily mean a change in his home life — and yet it may. Anyone who has read Pound's "The Iron Man in Industry" cannot help but feel that power-driven machines do affect men in different ways from hand-power tools that require individual initiative and skill.

Rural
Districts

Very little information is at hand regarding the changes taking place in the rural districts, in which are living and working the vast majority of China's industrial population, and the ones wherein the most fundamental economic industry is carried on — food production. One wonders how much change really has taken place in the life of the Chinese farmer during the last 2000 years. Certainly there are the kerosene lamp, matches, tin and other metal made implements, and cigarettes, but these are of only minor importance. It is high time that more people face the

* In the preparation of this article the opinions of quite a varied group have been received, representing both Chinese and foreigners in business, government, and Christian service. The writer deeply appreciates and hereby acknowledges the kind and thoughtful cooperation given by the numerous friends who have assisted him. In some places exact words have been used but, to avoid monotony, quotation marks have been omitted.

rural life of China and look to the future, for here certainly China can compete industrially and render a real service to the world. Food stuffs and cotton are in demand everywhere and China can produce these things economically and can compete in the world's markets, if she only sets herself to the task.

Open Ports It is in the open ports and in the other steam-served cities of China, however, that the greater and seemingly rapid changes are seen. Modern machines are gradually but surely pushing the handicraft industries backward and outward. The old-fashioned spinning wheel gives place to a complicated power-driven machine, and the crude looms are being displaced by improved hand-or steam-driven ones, because the articles are more cheaply produced and the quality usually improved.

Home Work-shop The home workshop must step aside for the small factories with limited capital and a few workers, and these in turn gradually give way to big concerns employing thousands and backed by millions in capital investment. At present small factories are proving more successful than the large enterprises, due chiefly to the lack of leaders with sufficient ability and moral character for large responsibilities. In the larger concerns the salaried managers displace the managing-owners with the result that the intimate concern of the employer for his business and for his employees that existed in the smaller shops, is lessened. For like reasons it is also apparent that commercially owned enterprises are more efficient and more apt to make profits than those owned and operated by the government.

Disturbances The numerous strikes that are constantly disturbing industry in most of the larger cities show that many evils of the industrial systems of the West are being repeated in China before the country has developed the means of coping with the social and economic change which attend an industrial revolution.

The products of industry tell of changes of economic value, such as those aimed at eliminating the necessity of importing from other countries. Locks, valves, soap, brushes, leather, nails, and machine-knitted socks, in-

dicating new demands. In many cases these things are produced by methods purely manual, while in others manual-machine methods are used with apparent effectiveness. Methods and products are continually changing to meet the demands of commerce. The trend is certainly away from hand-work toward machine-work. The quality in many cases is becoming better. It seems impossible that any wide spread changes can come as long as the military strangles the nation. The surprising thing is that industry has been able to develop at all under such difficulties.

**Developments
in Banking** No account of industrial and commercial development in China is complete without mention, at least, of development in the field of banking. There is no single factor of greater importance in a society organized along modern commercial and industrial lines than a good system of banks. Credit is essential if the wheels of industry are to move smoothly and commerce is to expand.

Banks, so called, have existed in China for hundreds of years but many of these banks have been little more than exchange shops with only a few of the larger ones interested in long or short time investing for productive purposes.

Modern banks in China are largely a development of the decade since the Revolution. They are the product of many forces. The presence of foreign banks has proved a stimulus and scores of returned students, trained in the methods of Western banking, together with men trained locally in the foreign banks in China have provided a trained staff. But more important still has been the ever increasing volume of trade which has clamored insistently for more and better credit facilities. In the absence of strong Government control the advent of modern banking in China, as was to be expected, was not without signs of mushroom growth. Failures however followed and failures brought their lessons with the result that Chinese banks have more and more tended to eliminate the speculative element in banking. Reserves have been more carefully guarded and care has been exercised in the

extension of loans. The Great War saw the entrance of Chinese bankers into the field of foreign exchange, a field hitherto a monopoly of foreign banks.

Modern Chinese banks are to be found in all of the treaty ports and large cities with more than fifty in Shanghai alone. The bankers are fast becoming organized and, in the strength of organization, have adopted a non-co-öperative policy towards the Central Government in the matter of making loans to the Government, a factor which is not without great significance. As the movement towards modern banking in China grows the bankers will be in a position to bring ever increasing pressure to bear on the Government. The bankers represent a large force making for peace and security within China and progress in modern banking is among the most hopeful signs in the country to-day.

Human Factor The movement from individual to mass production is accompanied by a concentration of population into small areas. The more crowded the district, the more difficult becomes the enforcement of sanitary and health measures. The fresh air and the freedom of country life is lost in the rush and the congestion surrounding the mill worker.

Many view these changes with deep regret and concern while others see in them, however bad they are, the promise of the better day. They view these changes as inevitable and bound to come whether we want them or not—transients on the road to progress.

The regrettable thing is that modern industry seems to carry an accompanying increase of poverty, at least poverty is here seen in its more objectionable phases. Closely related also are: a greater insecurity of work, more unemployment, children doing men's work, and women becoming wage-earners instead of home-keepers. Many men are therefore being pushed out by the lower paid women and children; some of whom take this chance to go into more remunerative occupations, while others see in it a chance to loaf allowing the wives and daughters to support the family, the percentage of men in this parasitic class being alarmingly high.

**Women in
Industry**

The chief cause for women entering industry is the stringent economic demand of the home, in some cases they merely supplement the family incomes but often the mother is the only bread winner. The present wage scale for ordinary labor is such that one bread winner in each family can hardly hope to bear the entire burden. A very careful study made in Wuchang showed that \$12 a month is the *least* a family of seven (allowing four children and one dependent relative) of the laboring class, requires for the lowest grade of living. The same study gave \$25 as the wage such a family *ought* to have for a moderately decent living.

Highly skilled mechanics to-day receive a wage higher in proportion to the cost of living than they did a few years ago. Ordinary mechanics receive more in actual cash but living costs have gone up as rapidly resulting in almost no improvement. The unskilled and transient laborers have a harder time because their incomes have not kept pace with the advance in cost of living.

**Skilled
Tradesmen**

In the homes of the skilled tradesmen conditions are better. In some, the children are given educational advantages where formerly it was considered sufficient that the son become an apprentice and work his way gradually into the skilled class. A combination of education and hard work is a change of real worth. There is an evidence of thrifty living on the part of some of the more highly skilled. For instance certain groups have accounts in modern savings banks and others in the postal savings. To our knowledge no definite coöperative plan has been worked out in any of these groups except a sort of a consumer's coöperative idea in a small way, such as combining in the purchase of rice when the prices are favorable. Extravagance is a tendency noted more frequently than thriftiness, but that must be expected as more money comes into the hands of those who are not trained in its proper use.

Women and children have always been workers in China but in occupations that do not require great speed and usually confined to piece work in their own homes. Handicraft shops, even with longer hours, injure children

far less than factories in which they are little more than parts of the machinery. A wider field of employment for women is now opening, and continues to grow as old industries are altered and new types started. Naturally there is some opposition on the part of male workers to this so called intrusion of women. For instance, the telephone operators in the Wu-Han cities have set up such a protest that the authorities dare not bring in women to be trained for switch-board work.

**Social Status
of Workers**

Although the Chinese Classics put the laborer high up in the social scale, it is a fact that workers have been looked down upon by the merchant, student, and official classes. A change of this attitude is evidenced by a growing recognition of the worker's place in society, and a more adequate provision being made for his welfare. The change in viewpoint is all too slow, and in many cases has come only through pressure. But a slow march is more likely to reach the goal than a forced and hurried one. The demand of thoughtful Chinese for educational facilities for the laborer, is a phase of this advance. The wide spread Popular Education movement (an evidence of this demand), is especially hopeful because it combines with the teaching of the most used characters, a foundation for intelligent citizenship.

There is in Hanyang a machine shop owner who feels strongly the need of a middle group of mechanics, with some technical and some practical training, to bridge the gap between the highly trained engineer and the ordinary mechanic. He wants men who are capable of becoming foremen through their ability both to think and to do the task better than those working under them. Leadership by doing instead of by talking is sorely needed in all shops. This owner has had poor success with technical middle school graduates for their educated heads seem to have produced impotent hands. He feels that the only efficient way to train such men is to give some technical training in his shop and to that end has worked out a very worthy system of promotions and certificates in recognition of passing certain stages in their development. He has found the human factor to be the most important element in successful shop management.

He has found that a nine hour day, and four free days a month, pay in better workmanship and bring larger dividends.

Foreign Supervision Common practice seems to prove the opinion that really important concerns cannot succeed without some foreign supervision because of the difficulty in controlling those that find capital and those engaged in production. This does not mean that there are no good engineers and mechanics, for there are some that rank with the highest anywhere, but their number is so hopelessly inadequate. Skilled workmen object to working under those that are untrained or wrongly trained for their tasks with the result that proper respect and discipline is lacking.

Comparing this period with what the future is bound to be, the change at present is slow. Now is the time for employers to plan carefully for the future. Everywhere a great need is expressed for men who, when working for other people, will be honest and ready to put their hearts into their work. This requires a change in the spirit of both the employer and the employee. An engineer of long experience in China, seems to think all too true the old Chinese saying, "Only a foolish man is honest and honest only because he is not clever enough to be dishonest," but adds, "I consider that those who are clever enough to be dishonest are often paid so badly that they cannot afford to be honest". The solution suggested by this engineer is not so much emphasis on education as upon conversion to Christian principles.

Labor Organizations Organized labor is not a new thing in China. Her guilds have exerted much influence throughout her industrial history. Many guilds include both the employer and the employee while most of them are employer's guilds in fact if not in name. The purpose of most guilds can be expressed as follows, "One product, one price, one principle, and protection." The changes in guilds tend toward more selfishness than formerly. The regulations are being altered, for instance, in the barbers' guild; the barbers in a shop formerly kept a record of the shaves and haircuts and a wage was calculated accordingly, this being merely a piece

work system. Now the barbers are on a day wage thus guaranteeing them a regular income; but perhaps the service to the master and to the customers is less efficient and of poorer quality.

More recently a new group consciousness on the part of the workers has grown up. This has come partly from within and partly from without the laboring classes. Much of the latter influence has been due to professional agitation by men who have never worked with their hands and whose motives have not been proved worthy of a following. It cannot be denied, however, that some of this new group consciousness is due to a natural uprising against unfair odds and unjust treatment.

More than ten years ago there were some people in Wuchang who promoted a labor union. It failed not so much because of its uselessness or from official opposition, but because the chosen leaders did not understand their duties and maliciously squandered the funds contributed. Since that glaring failure the laborers have been very cautious. For instance, in the Hankow rickshaw parleys of 1922-1923, the rickshaw pullers demanded twenty "listeners" at the meetings for they did not trust their three official representatives.

The flourishing rise of labor unions, following the successful seamens' strike in Hongkong in 1922, came to a sudden ending when the Hupch governor used powder and shot to put a number of railway union leaders out of the way and subsequently executed Mr. Shih Yang, the lawyer-leader of most of the labor movements in these cities. He has left behind some leaders and certain activities are still carried on by the remnants of the unions but most of the activities are secret and not connected with recognized organizations. A few head men may meet quietly together at an inconspicuous place and reach a common mind, but their influence is naturally limited. Some students and a few newspaper men are also at work though their activities are closely watched and severely restricted, and therefore ineffective.

Women Labor
Organizations

Formerly where both men and women were employed, the men usually represented the women when parleys were necessary, but the

female workers have found that they cannot trust the men to play fair. For instance, the money granted as a part of the settlement of the British Cigarette Company strike, was put into a savings bank and a seal in eight sections was required to draw upon this fund. A few men contrived to secure all eight parts of this seal and made away with some of the money but this set up such a disturbance that a change was made whereby no money could be drawn unless the seal was presented at the bank by four men and four women.

Head Men Another form of labor leadership is growing up that is extremely insidious and difficult to control. Especially in unskilled groups, such as the stevedores, there are the head men (liu mang they are called in this district) who are bold, fearless, unscrupulous fellows, who control by force, intrigue, and crooked scheming; in fact they are the very worst sort of men. They are not chosen leaders, but gain their places by physical strength, cunning, and cruelty. They are only recognized because their victims fear them. If the workers do not obey they are brow-beaten into submission or are caused bitter suffering until they knuckle under or get out. The result is that only rotten or weak willed men can work in such occupations. Morality and humanity are at the zero mark in such groups. As high as fifty percent is extracted from the worker's pay by these head men, the amount being regulated only by the comparative strength or weakness of the men under their power.

Similar conditions exist in the employment end of most of the larger factories. No job can be secured unless the employment men with inside pull are given their commissions, then they will exert their influence in the applicant's favor. The percentages demanded are unbelievable and often are not limited to the first month's pay.

In the old monarchical days these head men were strictly controlled, and very severe punishment was given by the officials when these head men became too powerful and too unjust to those under their control. Executions frequently did away with this unfairness until a new leader worked his way into power.

Not only do such laborers suffer to-day but the travelling public is their special victim. They force the strangers to pay "all the traffic will bear" and forbid reasonable men entering the trade. Foreigners can get by with a modicum of injustice, but all Chinese travellers suffer because of the influence of these unscrupulous bosses of unskilled, unorganized labor. This system includes not only the stevedores, baggage men, and others connected with the transportation systems, but also most occupations in which large numbers of the so-called coolie class are employed. The system often has the support of silk-gowned underlings in the transport companies thus making it most difficult to uproot and almost impossible to control.

We must expect to see many more unions spring up. Undoubtedly the workers will sooner or later get together. Some far-sighted industrial leaders are preparing for these changes, but very few are facing them fundamentally. Superficial preparations are all too common; while the majority of the people still ignore the future.

In these days of great uncertainty and travail it is highly important that all who desire to render the greatest service to China must face frankly and fearlessly these industrial changes. We must apply ourselves to careful study, not only of existing conditions here in China, but also of industrial developments in Hongkong, Japan, and India where Asiatic labor is at work and similar conditions exist, and where modern industrialism is farther advanced.

CHAS. C. SHEDD.

III. CHEFOO

The extent of the changes that have taken place in the industrial life of China has often been greatly magnified. Sometimes the few million dollars' worth of machine-manufactured goods largely exported to foreign lands, loom larger in our eyes than the supply required by the 400,000,000 Chinese which is in large measure still being produced and distributed by the old methods of industry.

**Type of
Changes**

On the other hand it would be utter blindness to fail to take into consideration the tremendous influence of these changes upon the whole life of China. These are far beyond their comparative magnitude as the influence of the port cities filters back into even the most remote villages. But for the rapid changing of the structure of Chinese industry, we must wait for the coming of coal on a large scale and for its accompanying corollaries of steel and railroads or for other newer materials and methods which will replace them. Besides the unmeasured weight of custom, industrial changes have against them the economic pressure of the masses. Old type industry provides employment for enormous numbers for which they receive enough to subsist. Until vast, undeveloped resources are opened up and provision made for their rapid transportation no comparatively large changes in the industry of China can be reasonably expected. The one outstanding problem is to increase production and facilitate transportation on an equitable basis so that the benefits will go to the mass of the common people and not merely into the pockets of a few already well to-do. China possesses sufficient material to support her own people on a reasonable standard of life, but these materials must be opened up, developed and equitably distributed. It is not only a matter of changing the industrial life of China but changing it in the right direction so as to bring the benefits to those who really need them.

**Causes of
Changes**

It is sometimes remarked that the industrial changes now taking place in China are analogous to the changes that took place in England and the West from 100 to 150 years ago. While there are some aspects and results of these changes that are similar, the underlying causes are from almost opposite sources. In the West the changes came with the coming of coal. The industrial revolution in the West developed rapidly as a spontaneous movement from within. At that time it would have been possible to have established modern industry on a coöperative Christian basis. It is here that the Church lost the opportunity of centuries. In China the changes that have taken place have come from pressure

exerted from the West. This competitive economic pressure has driven the Chinese either to adopt the method and system of western industry or to allow the industry of their own country to go into foreign hands. They have evidently decided upon the former course. So long as this influence of the West directs and dominates the industry of China, will it ever be possible to establish any other industrial system or to avoid its consequences?

The other day a Chinese returned student from America, now a successful business man in China, in a discussion group of English-speaking Chinese business men, declared that China never would have established modern industry if it had not been forced upon her from the West. They resented the fact that not only the system but all of its methods and evils had been transplanted to Chinese soil and that China was helpless to free herself from the strangling hold of the modern western system.

**Extent of
Changes**

There are two main types of changes noticeable in the industry of China to-day, one of which is the coming in of purely modern industry, the other is the change taking place in the old industries as a result of the new. The former type is limited to a few of the great centers most accessible to foreign influence and to a limited number of industries. The latter is a varying element reaching and affecting to some extent nearly the whole industrial life of the nation and resulting in a semi-modern type of industry in which there is constant strife for supremacy between the old and the new. Two local firms have recently dissolved as a result of this conflict and the Chinese Chamber of Commerce is divided into these two contending camps. The feeling of many of the ablest and most energetic Chinese business leaders is that foreign competition has made the purely old type impossible, but that custom, habit, and precedence equally prevent the sudden establishing of the new.

New Problems In both the pure and semi-modern types a number of changes are transpiring that are creating a new world with new problems which can only be rightly solved by a new system and a new spirit. Consider the changes wrought by the introduction of machinery and the factory system. Work that formerly required hundreds

or even thousands of hand workers can now be done by a score of men manipulating levers and wheels. Unless the undeveloped resources of the country are opened up how is provision to be made for those left out of employment? Almost every phase of life is affected by these changes but perhaps the most far-reaching results are in the social life.

No other one thing so seriously effects and so quickly tears down the old family life upon which Chinese civilization has been built. The old family home is broken up in its native place by the departure to the industrial centers of many of its younger and more enterprising members. In these centers the home life is revolutionized by the entrance of the women into factory work and by the removal of industry from the home to the factory.

Women in Industry The status of women in Chefoo has been radically altered by their employment in hairnet and lace factories. The wages they receive gives them something of a sense of economic independence and this in turn creates a realization of self-respect and freedom. The social contacts with large numbers of both men and women fellow-workers develops a group consciousness, greatly widens their vision, broadens their view of life, creates within them a dissatisfaction with present conditions and a real desire for a better way of life. Large numbers of girl workers have broken the marriage arrangements made by their parents and others are refusing to follow the desire of their parents to make such arrangements for them. They know too well the place of a daughter-in-law in the Chinese family and prefer the regular hours of factory work with their semblance of freedom and independence.

Hairnet and Lace Factories In this section the comparatively attractive opportunities in the hairnet and lace factories are causing great dissatisfaction amongst the working class of women. Domestic service has no appeal in the face of these factories and even such women as nurses are being attracted to this work. Living conditions at once become a serious problem involving great changes in the manner of life and fraught with extreme perils.

Large numbers of these women workers come in from the villages. With no adequate provision for living quarters or for leisure time, this first breath of freedom creates dangers too evident to need mention.

Employer and Employee Another outstanding change is that of the personal relationships between employer and employee. Under the old handicraft system the workers are often the members of the family or friends of the employer. They work side by side in the most intimate relations. Under the factory system this is all changed. The workers are hired, driven and fired by foremen who are subject to the owner and there is little or no personal contact between the owner and the average workman. In the minds of the workmen the owner is a far off impersonal being whom they seldom if ever see and from whom they receive their sustenance. In a recent conversation with the owner and manager of six silk filatures, he prided himself on the fact that he rarely ever steps inside one of his factories. In questioning the workers they have repeatedly stated that to their knowledge they had never seen the owner. This separation divides the interests, gives rise to misunderstandings, destroys sympathy, breeds suspicion, contempt and hatred and paves the way for open conflict and strife. By thus separating the owner from his workmen and segregating the workers in large numbers by themselves, there is created a group consciousness and a realization of their united strength, and labor unions in embryo are formed. Employers on the other hand naturally drift together for mutual protection against the workers, and manager's associations are brought forth and the fields prepared for battle.

There can be no doubt that momentous changes in the industrial life of China are in process. The greatest challenge to our Christian forces to-day is not only to be conscious of but to understand and to direct these changes. Let us not forget that movements and systems are directed most readily from their source, and that the source of this industrial system is in the West. We hear a great deal these days about avoiding the mistakes and evils of our

Western system in China as though it were merely a matter of a few small changes here and a little shifting there. How long will it take us to learn that it is impossible to avoid un-Christian results from an un-Christian system, that a corrupt tree will inevitably bear corrupt fruit and that it is the system which must be changed in order to avoid the evil consequences which we fear and hate. We must not only recognize the changes which are taking place, but we must direct them from their source.

J. W. NIPPS.

CHAPTER VI

WHAT IS EXTRATERRITORIALITY?

Charles Sumner Lobingier.

Definition The Editor has asked me to write, in answer to the above question "a brief, succinct statement of where extraterritoriality originated and what it actually means, particularly with reference to Christian work in China. Of course, its relation to merchants should also be noted." I shall try to meet these requirements, confining myself to a definition of the subject and a discussion of its historical development, without attempting to treat of its merits or demerits.

Extraterritoriality, or more properly "extraterritorial jurisdiction," is a system under which a sovereign power retains full control of its nationals in territory outside its own. This necessarily excludes the exercise of control over the same national by the sovereign power of the territory in which he is located. In other words the national remains under his own laws and institutions instead of becoming amenable to those of the locality.

Origin Contrary to popular belief, extraterritoriality is neither novel nor, historically speaking, exceptional. It is in fact the result of a legal conception which was once nearly, if not quite, universal. For whereas jurisdiction is now generally territorial it was once almost if not quite universally personal. Ancient law, in other words operated upon individuals wherever they might go and was not, as is generally the case now, limited by territorial boundaries. In reviewing Brown's "Foreigners in Turkey", Dean John H. Wigmore, a very eminent American jurist, observes:

"We venture to suggest, with diffidence, that the naturalness of the exterritorial privilege, as explained by the author, might be more emphatically illustrated by the 'personality' of all law, as distinguished from

its 'territoriality,' which prevailed throughout the vast Carolingian empire till nearly 1,000 A. D.; i. e. instead of saying, with the author, that extraterritoriality was 'in accordance with usage which became generally recognized with the gradual extension of commerce,' we should prefer to believe that it was in accord with a universal prior custom prevailing in the first half of the Middle Ages".¹

Another distinguished author has said:

"The conception of sovereignty as territorial is relatively modern, and extraterritoriality is a surviving form of the earlier prevailing conception that it was the duty of a sovereign to protect those who swore their personal allegiance to him".²

This glimpse of its origin may serve to correct certain misconceptions regarding extraterritoriality. When we find that it was once a universal system, observed by the strongest as well as the weakest, powers, we need no longer think of it as an invasion of sovereign rights. Again, under the former conception of sovereignty as personal, it is easy to see how one nation might not care to be responsible for the subjects of another, though residing in the former's territory. Thus as early as 1687, it is recorded, a Chinese official suggested that an English offender in China be punished by his own nationals.³

From Roman Law But extraterritoriality did not originate in China nor even during the Middle Ages. For the germ of it we must resort, as in the case of so many other important legal ideas of modern time, to the Roman Law.

"The so-called system of personal law, of the earlier Middle Ages," declares Von Bar,⁴ "is only a development of the system which the Romans had already observed."

The system was continued under the barbarians who conquered Roman territory and who, though introducing

1. Illinois Law Review, X, 451. Cf. Hinckley, American Consular Jurisdiction in the Orient, 17.
2. Piggott Exterr. (new ed. 1907) p. 5.
3. Fames, The English in China, (London, 1909), 40.
4. Priv. Int. L. (Gillespie ed.) p. 15.

their own laws, allowed their Roman subjects to retain theirs. Similarly the Italian states of the early Middle Ages permitted foreign officials and tribunals in their midst to handle the affairs of their own nationals; and so in Spain, France and even England.⁵ All this existed for the most part independently of treaty and because of the recognition of law jurisdiction as personal rather than territorial.

In China CHINA has not been different from other nations in this regard, though one who studies merely the treaties might acquire that impression. But extraterritoriality existed in China centuries before it was mentioned in any treaty and probably before China had negotiated any treaties with foreign powers. Thus it is said that about 720 A. D. a maritime tribunal similar to that of the admiral in Europe, including the function of deciding causes among foreign merchants, existed at one of the ports of China.⁶ We have already noticed the instance of 1687 and the importation of the "factory" system from India by English merchants⁷ necessarily brought with it English laws and officials functioning for the "factory". In 1834, a full decade before the recognition of extraterritoriality by any treaty, an English "Act to Regulate the Trade to India and China" provided that the superintendent of British trade in China might be empowered by orders in council to create a court of law for trying offences committed by British subjects in Chinese territory.⁸ So when Caleb Cushing came from America to negotiate its first treaty with China he found the system of extraterritoriality already in existence wherever foreigners were located, although the treaty of Nanking, signed less than two years previously, makes no mention of it.

For the distinguishing feature of the treaty of Wanghia was not that it originated extraterritoriality — that is a popular misconception — but that it frankly recognized

5. See the writer's article "Extraterritoriality", *Corpus Juris*, XXV, 302, 303.
6. *5 Journ. Asiatique* p. 40 (citl Miltitz *Manuel des Consuls* (1837) p. 162 note).
7. Hunter, *Fan Kwae at Canton*, 20.
8. *The Weekly Review*, October 14, 1922.

the system, defining and regulating it in specific terms. The treaty of Wanghia, in other words, was a voluntary pact between equals. No force or coercion was employed and no undue advantage sought. America received and China granted, privileges which other nations had long enjoyed but which in this instance were hedged about by certain restrictions and balanced by certain obligations.

System of Reciprocity For extraterritoriality is a system of reciprocity and operates with success only when each contracting party observes its respective undertakings. The nation granting it is relieved of all responsibility for the misdeeds and disputes of the other's nationals; but this responsibility is merely shifted; it is not cancelled and the power enjoying extraterritoriality assumes a burden even greater than that which exists in its own country. For there any failure to enforce its laws and adjust rights and wrongs affects its own people alone. But in an extraterritorial country such failure affects also the people of that country as well as other foreigners who reside there. Thus extraterritoriality, like any other mutual or contractual relation, requires the utmost good faith on the part of those adhering to it. Whether we like it or not, we who are nationals of powers enjoying extraterritoriality, have the duty of seeing that, so long as it exists, the spirit and purpose of the system is observed with scrupulous care. Criticisms of it arise more often from its non-observance and from the lack of good faith in carrying out its purposes than from inherent defects. Each one of us can help to make the system less objectionable and more workable by recognizing and remembering that we have an individual — yea a patriotic — duty to see that the obligations of our respective governments, operating as they must through their nationals, are carefully and conscientiously observed.

PART II

CHRISTIANITY AND THE RELIGIONS
OF CHINA

CHAPTER VII

CHANGING STANDARDS IN MORALS AND RELIGION

Guy W. Sarvis

Basis of study The writer, as a teacher of Sociology and Economics, comes into contact chiefly with students, although it is also his business to investigate social facts of all kinds. The conclusions of this chapter are based not only upon his own observations, but upon the judgment of some of the leading men in China, supplemented by the opinions of a large number of students. There is a surprising unanimity of judgment among these persons in very diverse situations.

Confucianism Has there been progress or the reverse in Confucianism and Buddhism during the last twenty years? With reference to Confucianism there is practically complete unanimity of opinion that its force as a standard of conduct has greatly and rapidly declined. One business man says: "That it has been on the decline especially for the last twenty years is a patent fact." He explains this fact by saying, "With the abolition of state examinations one of the most powerful incentives to the study of Confucian books was removed, and it has become a common occurrence to find a school boy who does not know what the Four Books are The next formidable cause of the neglect of Confucianism and its books is in the introduction of foreign languages and Western ideas and religions. No struggling young man of the present day can afford to devote himself solely to

Confucianism if he wishes to get a living. He has to follow the general trend and fashion, and when noted scholars like Kang Yu-wei, Chang Chien, and Liang Chi-chao, having attained eminence by their intellectual excellence, do not inculcate the Doctrines, Confucius must for the present remain in vague respect, and an empty name." These opinions are shared by all, although there are not lacking those who believe that a reaction has already set in, and that Confucianism is destined to enjoy a revival. Nevertheless, the general opinion is that Confucianism, being autocratic and absolutistic in its nature, will be unable to serve the needs of a dynamic, democratic society. A study of current writers confirms this judgment. The leaders of China are indifferent, contemptuous, or actively opposed to Confucianism. These new attitudes affect chiefly the educated classes, and particularly those living in cities, but they are by no means confined to these. Testimony from rural districts confirms the opinion of those from urban centers, that Confucianism is gradually losing its hold upon the common people of China as well as upon the educated.

Buddhism With reference to Buddhism the testimony is almost equally clear. Buddhist practices, superstitions, and temple worship are generally held to be declining somewhat. And even though they may not be actually decreasing, their hold upon those who do practice them is less absolute. Probably fewer people are becoming Buddhist priests than was formerly the case. Buddhist and Confucian temples have been used in large numbers in recent years as schools and as barracks. Although there are isolated reports of building and repairing, the number of temples is decreasing, and the number of worshipers is likewise less than formerly. The question as to whether more or less is being spent for incense, candles, paper money, and other materials for worship does not receive a unanimous answer. Some are of the opinion that these things are very evidently on the wane. Others are of the opinion that they are increasing. It is a significant fact that in times of prosperity more money is spent for these purposes than in times of adversity, even though the intensity of the belief which

gives rise to the practices may not vary. It follows that judgments about the changes in religious beliefs based on the amount of money spent in religious ritual are somewhat untrustworthy.

On the other hand the principles of Buddhism are attracting more attention than formerly as evidenced by the output of Buddhist publishing houses in Peking, Nanking, Hangchow, Shanghai, Chengtu, and other places. There is general agreement that this revival of Buddhism, while due to a number of other causes, is to a considerable degree the result of social and political unrest which causes men who are by temperament or training idealists to turn from the transient and unsatisfactory things of the present world to the philosophical abstractions of speculative Buddhism. This renewed interest in Buddhism has not, however, resulted in many organized movements. Nothing corresponding to the Buddhist revival in Japan has taken place.

**Eclectic
Movement**

Aside from these changes in Buddhism and Confucianism there are a number of other significant changes in the religious life of the country. On the one hand, there is the anti-religious movement among a certain section of the "intellectuals." It seems to be the general opinion that the opposition to Confucianism is, to a considerable extent, atheistic and materialistic in character. Religion itself is felt by many to be merely superstition. The revolt against historical religions does not, however, exhaust itself in atheism and materialism. There has been a remarkable increase in various eclectic sects and organizations. One of these, the Tao Yuan, has been described at length in the "Chinese Recorder." I am informed that there are twenty-three religious organizations in Nanking which use the planchette (fu chi) as a means of communicating with the spirit world. Most of these sects are attempting to combine the good in all religions. They are in general promoted by scholars, ex-officials, and members of the middle class. Most of them practice some form of social service. Many of them conduct schools and profess to heal diseases, and almost all of them claim to be in communication with supermundane spiritual forces. They are unquestionably

the outgrowth of the disorders of our times, both in China and in the world in general. So far, there is little promise that these movements will exercise any important influence on conduct among the Chinese people. The question whether Christianity is or is not gaining in influence is one on which there is much disagreement. It is quite evident that among the people as a whole there is less opposition than formerly, but while some are turning wistfully to the religion of Jesus, others are turning away from all religion. Again and again the answers to my questions indicate that the Chinese people are largely indifferent to spiritual religion.

The answers to the question "What type of religion do you consider best suited to the Chinese temperament," are quite inconclusive. The one significant attitude revealed is that Confucianism must be the basis for any successful religion in China. Some advocate a socialized Buddhism. None feel that Christianity and the older religions in China are mutually exclusive. There is a strong tendency to emphasize the ethics of Christianity as opposed to Christian philosophy or theology. Among students who are Christians, Christianity is unqualifiedly accepted as the best; but among business and professional men of greater maturity, not one believed that Christianity as traditionally presented was best suited to China.

Philanthropy One of the marks of religion in all lands and ages has been philanthropy in one form or another. There may be philanthropy without religion, but there has rarely been a religion without philanthropy. There seems to be fairly complete agreement in the opinion that organized philanthropy is on the increase. The writer above quoted says, "There are more organized charities than before, but undertakings of a permanent nature and of great magnitude are still lacking. It is gratifying to find some educational institutions, started and maintained by single individuals, running more smoothly than publicly supported institutions."

One teacher ventures the following opinion, "Formerly it was much easier for the beggars to secure help from the people, who regarded this kind of giving as morally meritorious. At present most thinking people

would regard this kind of private charity as cultivating dependence on the part of the poor." This statement doubtless reflects the student rather than the popular point of view, but is indicative of a trend in public opinion that is of some significance. On the whole there is little change in the matter of charity except in the large centers where great philanthropic organizations are being built up, and in the case of famine relief, and similar organizations. There has been little progress in the development of the essentially religious attitude involved in group conscience and coöperation, and expressed in organized benevolences.

Superstition In the matter of increase or decrease of superstition we find no certain reply. It is true that among educated classes superstition is somewhat on the wane, yet, as is pointed out by several, the degree to which even Christians and graduates of western schools cling to superstition is somewhat surprising. The opinion of one writer is as follows: "Boys and girls at school seem to be now less superstitious, but to look at the numerous physiognomists, fortune-tellers, geomancers and quacks, who are still able to earn a living, and the increasing consumption of joss paper money, I cannot say that superstition is on the wane, for the general people are still very credulous." Here again we conclude that a criterion of change which at first sight would seem very reliable is after all untrustworthy. Superstitious practices may persist, or even increase long after their power has largely disappeared, (witness our prevalent superstition about 13, spilling salt, and similar matters). There can be little doubt that the strength of superstition has greatly waned, even though its practice continues as before.

Old Religious Practices With reference to religious practices in general it may be said that among the great mass of the population the old practices continue with little change. That they are being gradually forced out by the pressure of high standards of living there can be no doubt. A smaller and smaller *proportion* of expenditure goes into such practices except where they are identified with display of one kind or another. In the case of weddings, funerals, and other practices that are partly religious and partly social in their nature, they tend to

become more elaborate and more expensive. The motive for their continuance, however, is decreasingly religious, and increasingly social, namely, the desire not to be out-done in expenditure by one's neighbors. This element of social fellowship and competitive display has always been prominent in these matters, and it is entirely possible for a ceremony which was originally religious in motive to continue long after all religious elements have disappeared. Among westerners marriage and burial ceremonies in many cases illustrate this fact.

Business Ethics In the matter of business honesty there is again conflicting opinion. It is evident that Chinese society is passing from status to contract. Commercial agreements are valid if written or published, but verbal and informal agreements are not observed as formerly. The break-down of the family system leads to greater individualism in business, and the family is no longer responsible for fulfilling the obligations undertaken by its members. More and more, shops have fixed prices and guarantee their goods. In the more progressive cities the old fashioned standards of business honesty have been largely swept away in the case of large dealers, and in their place modern commercial practices are being substituted. The process is by no means complete, but is rapidly taking place. In connection with the change, however, many abuses and much confusion are arising. Times of change are times of opportunity for the rascal, and business men agree there are many such abroad in China to-day.

Classic Virtues There is no question that filial piety and loyalty and the other classic virtues are greatly weakened. It is becoming the fashion for young people to declare their independence from their elders. The traditional conceptions are sharply criticised by some as tending to servility on the part of the young and those of low estate, and absolutism and arbitrariness on the part of those in authority. In some quarters the break-down of the traditional loyalties is gradual and more or less unconscious. The idea that all parents are infallible, and all kings beneficent, is no longer seriously entertained by thoughtful people. It is impossible in a brief statement to indicate the grave significance for Chinese society of the

break-down of these ancient attitudes. They are at the base of Chinese family and social organization, and their weakening is like the removal of the mortar from a brick wall. Yet this weakening is inevitable. In this "as in other innovations in China, we may expect a turn for the worse before a good result can be obtained," as a Chinese correspondent remarks. No greater problem confronts China to-day than that of building up standards and loyalties that will take the place of those that are crumbling away.

Sex Morality In the matter of sex morality generalizations are likely to be untrue. Perhaps the most obvious thing to say would be that China is repeating the history of other nations. The flaunting prostitute along the main lines of communication is witness to changes in standards if not in practice in these places. It is a well known fact that in communities where all members are known to each member, the control of sex impulses is much more certain and complete than in situations such as we find in modern cities where personal relationships are reduced to the minimum, and where anonymity is the rule rather than the exception. There can be no doubt that the modern hotel, the railway, and the steamship have greatly increased commercialized vice. Likewise city life always tends to the increase of loose relationships between the sexes. The whole question of marriage, courtship, concubinage, and equality between men and women is too complex to be dealt with in this paper. All agree, however, that in each of these particulars there is a loosening of old standards and an absence of new ones which constitutes an unusually serious problem.

Lawlessness There is complete agreement that the people are less law-abiding than they were before the beginning of the Republic. Official proclamations are universally disregarded unless some visible manifestation of power is invoked for their enforcement. Public criticism of officials, in newspapers and by word of mouth, has become common. In some cases students and merchants have refused to accept officials appointed by the central government. The disorganization and weakness of the government at Peking is to some degree responsible for the

conditions mentioned, but the ideas connected with democracy, bolshevism, and free thought have undoubtedly had great influence over the people. Brigandage, piracy, and constant revolution have contributed their share. It is difficult to see where these tendencies will lead in the absence of any government which the people are compelled by custom or fear to respect. Local government continues relatively efficient, but even there the forces of disintegration are active.

**Family
Morality** The question as to whether families are providing for their helpless members is raised because the answer will reveal the extent to which the old family morality is breaking down. Statistical replies are, of course, impossible. It is unquestionably true that in rural districts and in those parts of cities which are populated by old families the care of defectives and dependents is still assumed by the family. Many institutions for the care of these classes which are necessary in our individualistic western countries have not been developed in China because the family system made them unnecessary. There is very much to be said in favor of this family responsibility, but in this particular, as in others, we cannot escape the fact that, at any rate in the great cities where changes of moral and religious standards are made and disseminated, the public is being compelled in constantly increasing measure to assume those functions which were once performed by the family. In other words, the old family system with its mutual repression and its tendency to develop parasites on the one hand, and its mutual responsibility and tendency to protect society from the criminal and the weakling on the other, is crumbling under the impact of modern industrialism and urbanization which make necessary the separation of working men from their parents and the old home.

Summary The situation is succinctly summarized in a letter written October 27, 1923, by the late Dr. K. S. Liu, Dean of South Eastern University: "There is a general break-down of traditional standards and values. In place of the filial attachment there is a more individualistic tendency, and at the same time a social emphasis. Superstitious practices are disappearing, but

due to lack of general education they still persist among the illiterate classes, though it should be said that, due to habit perhaps, even people with some education, and especially men of the older type, still have some faith in geomancy and the like. At the same time, clairvoyancy and theosophy are spreading among certain classes of people in certain places, but this I attribute to the unsettled political conditions which make men crave for another world, or some sort of spiritual situation.....The most deplorable thing is the break-down of the old standards of moral worth."

The conclusion to be drawn from this study is not pessimistic. New wine cannot be put into old bottles, yet human nature is such that the attempt is inevitable. The necessary result is the destruction of the old bottles and the provision of the new—in the form of altered social attitudes, values, faiths, loyalties, and organization. It must be apparent to any clear-thinking person that this disintegration of ancient faiths and morals will continue for an indefinite period in the future and that the supreme task of Christian leadership is somehow to build up the new faith and new morals for a new age. It is a constructive task. Destructive forces spring up spontaneously, constructive forces must be created. The creation and organization of such forces is the mission of all who are interested in the welfare of China.

CHAPTER VIII

RECENT RELIGIOUS MOVEMENTS IN CHINA

Gilbert Reid

Of late there have arisen many new movements and associations devoted to matters moral and spiritual. Three characters represent these associations (會, 社, 院). None use the special characters denoting some religion. However, in the principles and practices of most of these associations recognition is given the five religions, namely, Confucianism, Buddhism, Taoism, Christianity and Islam. Of these five, Confucianism is generally accorded the pre-eminence. In matters of form and ceremony Buddhism takes the lead.

In describing these various associations, I shall divide them into four groups.

For Promotion of Righteousness L. In Group One the emphasis is placed on *righteousness*, first in the heart and then in conduct.

(1) The first one is the Society for Purifying the Heart (洗心社). This movement originated a few years ago in Taiyuan, the capital of Shansi, "the model province" of China. The movement was encouraged by Governor Yen Hsi-san and was promoted by one of his Staff. The source of political reform was seen to be in the individual, and, as to the individual, in his heart. In carrying out this reforming idea the following methods have been used:—

(a) Use has been made of the printed page and (b) the lecture method, or preaching, has been adopted. The Governor, as a part of his statecraft, has also adopted these two methods in establishing a stable government and caring for the people. He has a lecture-hall in his own *yamen* and has erected a larger hall for lectures open to the public. Proclamations exhorting to right living, sheet tracts and "good books", are all made use of, in direct or indirect connection with this Heart-Purifying Society.

(c) Those who are linked with this Society have kept the Confucian Temple in best repair of any in China, and this because the halls and courts, besides being set apart at stated times for worship of the Sages, are turned into a modern educational enterprise with library, reading-room and an attractive educational exhibit.

(2) Two other Societies devoted to "works of righteousness" are almost alike in name (同善社) and (悟善社), the Association for Advancing Goodness. They have their headquarters in Peking, and branches in a few provincial towns. The former was started about six years ago, and the latter two. There are four characteristics. (a) One is devotion to deeds of charity. (b) A second feature is that of exclusiveness, or secrecy. This is more in connection with certain rites and aims. It is somewhat like the mysteries in Greek and Roman religion. (c) A third feature is the use of silent meditation in the spiritual training of one's self. (d) The second society mentioned also makes use of the planchette to receive responses, like the Greek Oracles, from favorite divinities: it also uses spirit photography. These features are also seen in another prominent society, which will be dealt with later on.

To Promote Moral Ideals II. Group two consists of movements centered around morals or moral-ideals, with which there are religious and spiritual principles and rites. The Chinese words (道德), translated "morals" or "truth and virtue", are near in concept to the English word "religion", or the words "being religious". There are four of these organizations. Moral character is made the root of all things.

Universal Moral Association (1) The Universal Moral Association (萬國道德會). The organization only began some three years ago in Tsinan, but the movement or its moving ideas had been in existence a decade before. The following are the chief features of the Society and the movement:—

(a) It has prepared and distributed many books, explaining in simple language the meaning of the classics, both Confucian and Taoist, and adding exhortations to do the right. It is planned to interpret the Classics of the other religious Faiths.

(b) The movement is largely eclectic, recognizing the universal good in all religious teachers. The leader at present is a student in a Christian school, and is enrolled as a catechumen in the Methodist church.

(c) The movement had its origin in a young prodigy Chiang Hsi-chang (江希張) who began to expound the Classics before he was ten years old. In Chinese conception such a person is under enlightenment of the gods, and is spoken of as (神童). Like prodigies in other lands, he has lost his abnormal qualities, as he grows into manhood. However, this element of the unusual, the odd, or what many view as the supernatural, attracted many of the religiously-disposed. The followers are of the simple peasant class, without guile or pretense. On the other hand, the highest officials in the land have patronized the movement and have aided in the wide distribution of its literature.

(d) During the period of the Great War, as well as civil strife in China, books have been written against war and in support of peace. Herein it is akin to the Taoism of Lao Tzu, and to the main import of Jesus the Prince of Peace.

(e) Since the movement developed into an organization, it has had in mind to go beyond the bounds of China to other lands. For financial reasons this has been impossible. It has succeeded, however, in spreading throughout China, though each branch is a law unto itself.

(2) The Society for Moral Instruction (道學社). Its headquarters are in Peking and a few branches are found in the provinces. It differs slightly from the previous society.

(a) Like all the new movements it lays stress on sound morals.

(b) From the use of the word for instruction or learning (學) it makes morals or ethics a part of sound learning. The learned as well as those who are lovers of good deeds have joined the movement and helped in its maintenance.

(c) By selecting a particular worthy man as the head, to whom the rest show reverence, the old ceremonial

customs of respect to superiors are duly conserved. The Society represents Old China rather than the New Culture.

(d) Importance is placed on self-nurture and quiet meditation.

(e) Meetings are held for receiving the exhortations and enlightenment of moral teachers.

(3) The Tao Yuan (道院) or Ethical Society (道德社). The latter name was used first and is still used, but the former name is the one more commonly used, as being commanded from out the spirit world. As an organization it had its beginning in Tsinan in 1921, but in two years it has extended to Peking, to most of the capitals in North China and along the Yangtze, and to many of the cities in the province of Shantung. It is composed of the official and educated classes and has made remarkable progress, one branch being started in Japan.

The following are some of its leading features:

(a) Self-cultivation (內功, 或內修) by means of silence and meditation (靜坐). It is believed that through such a process good influences from the spirit world will help to mould the human spirit. Such training of one's self is regarded as the root of all worthy activities.

(b) The outward expression of the inner and better self (外功, 或外修) in deeds of mercy (慈善事業). Some of these deeds of mercy are homes for the crippled and unfortunate, giving medicine to the sick, relief to the famishing, and starting savings banks for small deposits of the poorer people.

(c) Recognition of the Spirit of the Great First Cause or the Primeval Ancestor of all mankind (至聖先天老祖). In the center of the main building is a tablet on which is inscribed characters telling that this is the seat of this Great First Cause (青玄宮一玄真宗三元始紀太一老祖). He is regarded as the True God. At the bottom of the tablet are the names of the founders of Confucianism, Taoism, and Buddhism, (項先師堯, 太上老君, 釋迦牟尼) and signs for Islam and Christianity. That for Jesus is a triangle, standing for the

Trinity (Δ). That for Mohammed is a curve, a sign of the True Lord () . Messages from the Primeval Ancestor are also indicated by a sign (\oint).

(d) The Society has a small book, which was delivered through the medium of the planchette by the Great First Cause and gives instructions as to the processes of Silence and Meditation.

Planchette (e) The particular feature of the Tao Yuan that has the greatest hold on its followers is the daily use of the Chinese form of a planchette (扶乩), by means of which messages are received, sometimes from the Great First Cause, sometimes from the Founders of the Five Religions and sometimes from others. One of these is Lü Tsu who lived in the Tang dynasty, one of the Eight Taoist Immortals. The planchette is used in two ways. It consists of a stick about a yard long, in the center of which is attached at right angles a curved stick less than a foot long. One man on one side of a table holds the stick by the left hand and another man on the other side with the right hand. The planchette traces characters in sand placed in a tray on the table. The two men are only the medium for the spirit to give its messages. In another form of the planchette a brush is attached to the curved stick, and characters are traced by it on paper. Most of the messages are dictated in good Chinese style, and, what is most striking, there is no message, as far as I know, that orders one to wrong-doing.

Spirit Photography (f) The Tao Yuan also makes use of spirit photography (圓光). These photographs, at first indistinct, are produced by a camera directed against a black cloth or turned towards the open air. One of these photographs is that of the Great First Cause. Another has been thus taken of the deceased head of the Tao Yuan at Tsinan and is true to the original likeness.

(g) The Tao Yuan is divided into five rooms or courts, each being set apart for some form of spiritual development. They are the Court of Worship (壇院), the Court of Scriptures (經院), the Court of Charities (慈院), the Court of Meditation (坐院), and the Court of Preaching (宣院).

**Court of
Worship**

It is the first one that is the largest and most important. In the center is the shrine for the Primeval Ancestor and the Founders of the Five Religions, as described above. On the right are two shrines, one for the Papal Seat of all the Tao Yuans (總院總壇) and one for the attainment of Scholarship (文字壇). On the left are also two shrines, one for the local Tao Yuan in Peking (兆院統壇) and one for Petition or Inquiry (問事壇). In the Court of Scriptures there is a shrine for pictorial symbols (書畫壇), and in the Court of Charities there is a shrine for asking cure in time of sickness (求方壇). At each of these shrines the planchette is used as medium for the Spirits to make response.

(h) Another feature of the Tao Yuan is the synthesis of the Five Religions. As most of the adherents are devotees of Buddhism, Taoism and Confucianism, these three receive the most attention and are interpreted the most intelligently. Still, Christianity and Islam are treated with an open mind.

**Swastika
Society** (4) The Universal Swastika Society (世界紅卍字會). This Society is in imitation of the Red Cross Society. The character for Swastika (卍) is current in art and religion not only in China but in many of the countries of Asia. The Society was formed in the summer of 1922 in Tsinan at a gathering of choice delegates from different branches of the Tao Yuan. It is the outgrowth of the Tao Yuan, as the Red Cross Society is the outgrowth of Christianity. It was started under orders from the Primeval Ancestor, of mankind as made known in one of the worship-ceremonies at the Tao Yuan in Tsinan. It has already done much to render relief to the distressed. It carries out the special functions of the Court of Charities. As thus organized it issues a daily paper in Peking (卍字日日新聞). This Swastika Society is not separated from the Tao Yuan but seeks to carry out the principles of the Tao Yuan.

III. Group three consists of two Societies that put the emphasis on religion (宗教) instead of morals (道德) or goodness (善).

For Unity of
Religion

(1) The most noted is the Universal Association for the Unity of Religion (世界宗教大同會). This originated in Szechwan by Tang Huan-chang (唐煥章) who had come in contact with Christianity. When a branch was started in Peking, the principles announced were beyond criticism. Very soon it became known that this Society was sending out thousands of pamphlets telling of a great catastrophe to descend in the month of September, much like the Christian prophecies of the end of the world. The effect on the credulous was astounding, and the authorities found it necessary to close down all branches and warn the people against all such vain prophecies. On the good side this Society was absorbed in the search for truth and goodness, but on the bad side there was lack of an enlightened conscience.

(2) Quite a similar movement originated in Yünnan. It was named the World's Association for Unity in the Holy Religion (全球聖教大同會). The founder was Wang Chia-shu (王嘉樹), who having travelled all the way to Peking proclaiming his doctrines, sought to establish a branch at the capital. He showed an acquaintance with the Scriptures of all the Five Religions and was evidently a sincere truth-seeker.

IV. Group four represents the Old Learning of China. There is one outstanding society. It is called The Learned Society of Four Traditions or the Society for preserving four principles (四存學會). These four principles were first formed into a system at the opening of the Tsing dynasty by a noted scholar Yen Hsi-chai (顏習齋). The four principles were, preserving the doctrine of Man (存人), preserving the doctrine of (moral) Nature (存性), preserving the ancient learning (存學), and preserving government (存治). These ideas were incorporated into a Society and Institution in 1921 in Peking under President Hsu Shih-chang. A branch was started in Kaifeng. The central idea is more that of scholarship than of morals and religion, but as with the learned men of China in the past, so now, ethics and even spiritual truth are inseparable from true learning.

In a word, these various movements and organizations show that there is a stir in the religious aspirations of all classes of the Chinese. Everywhere there are those who are religiously-disposed, or as St. Paul said of the Athenians, "very religious," though groping in the dark and needing the true Light "that lighteth every man coming into the world." Others are also seeking after the truth and are amenable to reason and still more to the touch of sympathy.

CHAPTER IX

THE PRESENT STATUS OF CONFUCIANISM

F. C. M. Wei

Confucius. A more confusing expression can scarcely be found in the Chinese language than Kung Chiao (孔教), a translation of the English word "Confucianism" which has, during recent years, found its way into common usage. A considerable amount of unnecessary controversy has been caused by the equivocation of this term over the question whether Confucianism is a religion or a mere system of ethics. The answer depends of course upon our definition of religion and the meaning of the word Confucianism.

It is obvious that Confucius is not in the same class as Siddhartha of the Sakya clan and Jesus of Nazareth. Confucius preached no new religion, nor did he found a new church. He made no claim even to the glory of being a religious reformer. Religion was not one of his primary interests, which were almost entirely in the field of politics and ethics, subjects closely linked together in ancient times. His best parallel in Western history is found perhaps in Socrates who was born in Athens just a decade after the death of the Chinese sage in Shantung. A great deal that can be said of the one can also be said of the other. In religious questions, however, the attitude of Confucius was by far the less positive. But the two sages were alike in their loyalty to the existing religious institutions and practices of their respective fatherlands. Hence, it is not only improper to speak of any religion *in connection with Confucius*; it is even difficult to find a religion *of Confucius*.

Confucianism What, then, is the meaning of the current word "Confucianism" or of its translation Kung Chiao (孔教)? There are three conceivable meanings. First, we may mean by Confucianism the "Religion of

the State" that existed in China before Confucius' time as ascertained at present from the Book of History (書經) and the Book of Odes (詩經) which according to tradition were edited by Confucius and the religious ideas of which may therefore be said to have received his endorsement. The chief features of religion as there set forth are simply those of the faith of an agricultural people in an early polytheistic stage of religious development. The conception of nature is animistic. The spirits are vague and formless. A great god has emerged, but a hierarchy of deities is not yet formed. The objects of worship are the natural phenomena which are of the greatest concern to the farmer, namely, Heaven and Earth, Sun, Moon, and Stars, Mountains and Forests, Rivers and Seas, Cold and Heat, Flood and Drought, the Four Seasons and the changes of Weather. These are worshipped at proper times, if good crops and prosperity are desired. This religion has certainly shown a wonderful tenacity. It has persisted through all the centuries down to our own. However, changes have already set in. The annual sacrifice to Heaven which was formerly the greatest feast of the religion has ceased to be a great state occasion, and no one could now visit the Temple of Heaven in Peking, that colossal and glorious achievement of Chinese architecture, without being impressed by the fact that the classical religion of China is dying a natural death, and that perhaps without a mourner. It is one of the relics of ancient China. Its gradual disappearance seems inevitable, and so far no attempt has been made to postpone its exit from the stage.

Worship of
Confucius

The second possible meaning of the word Confucianism is the "worship" of Confucius in the Confucian Temples and in the schools. In the schools of the olden days, the ceremony took place twice a month as well as on special occasions such as the opening and the closing of the school each year. Incense and candles were burnt and the master and pupils prostrated themselves before the tablet of the Sage. There was no regulation about this, but people did it spontaneously. When schools along modern lines were established towards the end of the Manchu Dynasty, the

same ceremony was held on the first day of each month in the hall specially set aside in each school for the purpose. Since the establishment of the Republic such a hall is still found in most of the educational institutions which receive government grants or public support. But in a large number of these the ceremony is not observed even though the hall is there, and where it is observed, attendance is not compulsory for either teachers or students as it was under the old régime. In a few schools not even the hall is found and honour to Confucius occupies no particular place in the life of the school except the observance of a holiday on the anniversary of the birth of the Sage which is prescribed by the regulations of the Ministry of Education in Peking. This negligence of the "worship" of Confucius together with the abolition of the study of the classics as a required subject in the elementary and secondary schools effected in 1912 is for some people indicative of the decay of Confucianism. This feeling is enhanced when it is observed that the semi-annual ceremony of honouring Confucius in the Confucian Temple in the cities in the second and eighth months of the year generally referred to as Ting Tze (丁祀) is only performed by the officials as a matter of mere routine with but little of the spirit of reverence that characterized the occasion in days when the literary competitive examination was the main road leading to a political career. It is out of place here to discuss whether or not these ceremonies are religious in nature. But what concerns us at present is to point out that if the "worship" of Confucius is Confucianism, it certainly has its days numbered as far as people in the cities and in the modern educational institutions are concerned. As to the situation in the country districts, a word will be added later.

Political and Moral Tenets Thirdly, Confucianism is sometimes taken to mean particularly the system of political and moral tenets together with the social institutions and practices presupposed by them, as handed down from the remote past by Confucius and embodied now in the Confucian Classics. It may be summed up in the doctrine of the Five Relationships and the Eight

Cardinal Virtues, which are too well known to students of the Chinese Classics to need any further explanation here, and which though enshrouded in many rules now obsolete are yet the flowers of Chinese civilization that the world at large should not willingly let die. It is no part of any religious system. The worship of Confucius is not necessary to it. With the worship of ancestors it has only a collateral relation. Failure to realize these points has caused considerable commotion during the early years of the Republic. Alarmed at the change of attitude of the educational circles towards the worship of Confucius and the study of the classics in the schools and perhaps to a large extent irritated by the religious liberty clause in the Provisional Constitution adopted in 1912, a few of the Confucian zealots took the situation to mean the moral deterioration of the nation and measures were at once taken to launch a propaganda in the first year of the Republic, to establish a Confucian Association and to found even a Confucian Church in order to restore the Confucian *Kultur* to its former vantage-ground. A monthly magazine was published for a period of less than two years under the able editorship of Dr. Chen Huan-chang, author of "The Economic Principles of Confucius and His School," a two volume book edited and published by the Faculty of Political Science of Columbia University. Efforts were also made to have Confucianism adopted as the state religion of China, and having failed to accomplish this end by 1914, a new attempt was made in the period from 1916 to 1918 to secure in the would-be permanent constitution, then under consideration, government sanction for Confucianism as the basis of moral education in the schools. On account of the postponement of the adoption of the permanent constitution, the problem was held in abeyance, but it has not been entirely without effect, for in the new constitution promulgated on October 10, 1923 we find a clause to the effect that "citizens of the Republic of China shall have the liberty to honour Confucius and to believe in any religion," obviously a compromise intended to satisfy two contending parties in the Constitutional convention when the clause was considered and debated.

In 1914 the Confucian Association Monthly stopped its publication, and since that year not much has been heard of the Association itself. Here and there one may still find the sign-board "Confucian Association" hanging over the door of a building, but one might be disappointed to find little Confucian activities inside.

New Thought Movement In the meantime the New Thought Movement is directing its merciless attacks upon the social and moral teachings of old China, and few have come to the rescue of Confucius in his greatest distress. Now that the first wave of the New Thought Movement is apparently over, there is emerging in Hongkong and Shanghai a new Confucian Association bearing the title of Chung Hua Sheng Chiao Chung Hui (中華聖教總會). It is rather moderate in size as well as in influence in comparison with the older association. The latter was headed by some of the best known men of the country and had branch associations in almost all the important places in the Republic, while the former is even now scarcely known to the public and seems to have only a modest programme. The new association has also a magazine published fortnightly. It is called the Ngai Kuo Pao (愛國報) and has reached its fourteenth issue, but gives the impression of being only a feeble attempt. Another Confucian magazine, published by an individual under the title Shih Chieh Chong Ming Pao (世界昌明報) was started last September and is of about the same quality and influence as the first one.

As a whole this recent Confucian movement is rather insignificant when compared with the New Thought Movement with which it tries to cope. In the great centres and especially among the students, Confucianism, not only as the religion of the state or as the "cult" of Confucius, but also as a system of moral and political tenets, is rapidly losing its vantage-ground and looks as if it were threatened with complete extinction.

The situation in the interior is however, different. There in the country districts and as a rule in places where contact with the outer world is slight, new ideas imported by the New Thought leaders are not only not in vogue but not even heard of. There the old moral

system is still upheld as any moral system is ever upheld by a community. The Confucian institutions are still untouched by outside influences. Confucius is worshipped as before in the schools, although the regulations of the Ministry of Education have excluded the study of the classics from the school curriculum. By far the majority of people are still Confucian. This does not mean, of course, that they are all princely men (君子), but their professed ideal is still that of the Confucian classics.

But even in the interior this state of things is not to remain unchanged. Forces are at work to bring about some change before long. The leaven fermenting in the metropolises is bound to spread to the country districts. Further, it is significant that few of the leaders before the public eye are eminent in Confucian scholarship or pronounced in their enthusiasm for Confucianism. Naturally this cannot help exerting important influence upon the rising generation. In view of these circumstances our problem is not whether Confucianism will eventually have to make room for something new, but rather how its best may be conserved in order not to lose from the world that which has been fondly cherished by a great nation for a period of not less than three thousand years.

CHAPTER X

THE NEW CHRISTIAN APPROACH TO BUDDHISTS

Karl Reichelt

In dealing with this great and live theme I wish to draw attention to some of its most important principles as shown in the work of the Christian Mission to Buddhists, Nanking.

Principles of Approach

I. *The Approach is Christian.* We therefore stress what is most essential in Christianity. What is that? Nothing more and nothing less than Christ. Christianity is not in the first place a fine system of dogmas and masterly definitions, although these are also very helpful. Christianity is a person, a living, working person, the unique revealer of God our Father and Creator, who through his holy, unique life, his precious death and glorious resurrection has obtained eternal redemption for us all.

Therefore this new work among the Buddhists is from the very beginning and from the very bottom *Christo-centric*. The great aim is to *help our Buddhist friends see "the glory of God in the face of Jesus Christ"*.

II. *We must give the Buddhists the whole Christ.* This must be done not only in pointing out to them God's wonderful preparations in the Jewish people for the sending of His Messiah; not only by telling how Christ was born in Bethlehem and how he lived and died and rose from the dead, and now gloriously reigns at the right hand of the Father sending his merciful and omnipotent Spirit to all living beings in the universe. All this is very essential. But it is not enough. In the present Christian approach to Buddhists, Hinduists, Taoists and Confucianists, something very essential and important is lacking.

Scriptural Foundation

The scriptural foundation for the special principle to be explained here is to be found in many passages throughout the whole Bible, but is stated most clearly in the New Testament.

The apostle Paul refers to them in many places in his epistles, one of the best references for our purpose is Colossians 1:15-20 where he deals with the personality of our Lord, Jesus Christ.

But the principal passage is the famous introduction to St. John's Gospel, 1:1-5, 14.

There we see that Jesus Christ has been very real, very active from "the beginning". All that has been created has got its form, its life and its glory through him as the eternal word of God, the logos from above.

Furthermore you will notice that the significant word in the 5th verse is "The Light". "Life" and "Light" are used in the fourth and fifth verses. The "logos" as Light is said to have a wonderful aim and function.

"The light shineth in the darkness; and the darkness comprehended it not."

The Logos Here is the history of religion through all ages given in a nutshell. Christ is the "word". The logos has been shining from the very beginning and shines through all eternity. This is His permanent function from the first days of creation, when God's will was manifested in the mighty works: "Let there be light and there was light".

It means that the special and unique revelation of God in the Old Testament originates in Christ as logos. But it means more still.

According to the context of St. John's Gospel it means that this light is forcing its way through religious systems all over the world; that everywhere He has not left himself without witness (Acts, 14:17). And so great is our God, that he could afford to give not only his chosen people, but mankind everywhere, *holy men, prophets*, men like Melchisedec of old, Laotzu, Confucius, Buddha, Zoroaster, who could receive the logos and reflect His beams through holy and devoted lives and through holy writings. When we study these books we find in their obscure words many beautiful and divinely inspired passages, just as St. Paul the tenderhearted missionary of old found such expressions in the Greek classics. For instance in Athens when, in that famous sermon given in Acts, 17, he quotes from the

neo-platonists Cleanthes and Aratus: "For we are also his offspring". The same was the case when he walked round among the temples in Athens. He met many things which grieved his heart. But lo, among the many images and shrines he found in a corner "an altar to the unknown God." This he used as a starting point in his sermon. It was a beam from the logos, now incarnated in a historical person, whom he loved from the bottom of his heart. And a beam from my most beloved Friend and Master can not but fill my soul with joy.

This is what Justin Martyn calls the *λόγος σπερματικός*. The word, which like the seed is lying hidden within the systems of religions all over the world and which brings forth refreshing green leaves and fragrant flowers in the great desert of superstition and heathen darkness.

Many missionaries are frightened, when they find anything good and true and noble in non-Christian religions and worship. They try to explain it as nicely veiled diabolic delusion.

But there are other missionaries who with sincere and wholehearted joy receive these beams for what they really are, tokens of the omnipresence and omnipotence of the eternal logos, Jesus Christ, who is the source of light and life from eternity to eternity.

This attitude will enable us to do *justice to all men*. "*By manifestation of the truth commending ourselves to every man's conscience in the sight of God*" (II Cor. 4:2). It will open our way to the conscience of all truth-seekers, Buddhist, Taoist, Confucianist, or whatever they may be.

A few words about the development and progress of the Christian Mission to Buddhists are in order. I laid this scheme before Christian Chinese leaders and interested missionaries gathered in Shanghai in connection with the China Continuation Committee meeting of 1920. The scheme was heartily approved. A number of letters of introduction were given me as I started home for furlough.

Most of my furlough lecturing, in Scandinavian countries, the north of Germany and in the United States dealt with this topic. Everywhere I met with interest and

Christian
Mission to
Buddhists

sympathy. But the financial depression is felt everywhere and friends will naturally hesitate to give large sums in such times.

We have not the working machinery in running order at least in Scandinavia. My own home board decided to set me apart for this special work and a young and very able man, Mr. N. N. Thelle, was sent out with me to assist me as manager so as to enable me to plunge into the real work as soon as possible. The Swedish State Church Mission has pledged itself to stand behind this work and will send out a pastor later on to join us. The Danish Missionary Society will do the same and will send an expert architect to be in charge of the building of our institute, which we hope to erect.

Mr. Thelle and I came back to China in October 1923. We have already, by God's wonderful grace, got a place in Nanking, where we have opened the work in a humble and simple way. Monks are daily coming for conversation and reading. I have had some very interesting experiences with them. Also lay Buddhists devotees, Chü-sī, and people belonging to the vegetarian sects have met with us in devotion and worship. In the monasteries we have been received most cordially, and many of the leading abbots have been with us at our vegetarian meals; for we, of course, are all vegetarians here.

Social Intercourse and Training But we may go further. In addition to cordial intercourse, we must get some of the earnest and most religious monks under constant care and instruction. With this in view we have extended our little place in Nanking so as to make room for a school and "hall of hospitality". Sixteen young novices, mostly coming from the small temples in the neighborhood of Nanking have been given over to us and get daily Christian and secular education in our school. Two monks have already been baptized and a few others are preparing for baptism.

At our Sunday services we have fairly good audiences of monks who come from the monasteries and temples. Some very interesting men have come from some of the religious associations in Nanking, the Tao Yuan etc. Pilgrims are allowed to stay in the "Hall of Hospitality"

for three days. If we find that they are of the special religious type, we invite them to stay for longer periods.

Of course some of the bad type also come. But they do not like to stay here and depart very quickly, not finding the earthly gain they sought.

Beside daily worship, morning and evening, we also have a special hour for meditation and prayer. One of our helpers sits quietly in the "hall of hospitality" and gives about half an hour to explaining religion.

It is very touching to see how pious Buddhist and Taoist monks like this hour and how of their own will they continue to study the Bible and perform their private meditation in our prayer room or elsewhere. We have succeeded in purchasing a fine hill about one mile outside one of the eastern gates of Nanking. There we hope after a few years to erect the institute. Some of our Buddhist friends have done agricultural work out there.

Later we hope to start a small industrial plant in connection with our place in the city. We must help those of our Buddhist and Taoist friends, who are becoming Christians, to learn something whereby they may secure a living.

The hill we have bought in the country is called *Ching Fong Shan* (景風山), these words are taken from the Nestorian monument. They mean the "illuminating wind" (spirit) which blows from above, stirring up the heart to new religious life.

CHAPTER XI

CHINESE ISLAM AS AN ORGANISM

Mark E. Botham

To the visitor, as to the home student of missions, and even to some residents at coast ports, the word "China" conveys the idea of a crooked coast line, great cities such as Peking, Shanghai, Canton, a long river coming from somewhere beyond Hankow, and a vast unknown region to the West. Whether or not this idea of the vast Republic be either just or correct politically, one would not venture to decide, but a few years residence in that mysterious interior of the North-West, followed by a journey through a number of the Provinces of the East and Centre, has convinced the writer that it produces an entirely false impression of Chinese Mohammedanism, which judging by ideas gathered at the coast ports, has been placed in the category of those sects that are of some interest but need hardly be taken into consideration in the missionary programme.

Uniting Influences

Although in the East and Central districts one finds in the Moslem communities such modern movements as result from contact with the Western world, the real uniting forces of Islam, springing from the essential characteristics of its organism, and the religious divisions common to all Moslem countries and communities, find their source in the far North-West, where China Proper is linked with that vast region of Central Asia, inhabited by a conglomeration of little-known Moslem tribes. In Nanking a school was founded for the instruction of theological students in Arabic, Persian and Islamics. The ahung (or mullah) who taught Arabic was from the extreme North-Western province of Kansu. A sect whose beliefs constitute a division in the fabric of Islam, and whose followers are considered by the majority of Chinese Moslems as heterodox to the point of

infidelity, has branches throughout Eastern, Central, and Southern China. The traveling ahung whose mission it is to encourage them comes from Kansu, where resides the leader of the sect. In short the actual, though not necessarily the recognized center of the Mohammedanism of China is in the West and more particularly the Northwest. When this fact is kept in view some curious anomalies are explained.

Chinese Islam Islam in its Chinese manifestation has often been considered a counterpart of the Christian Church in China and there is much to support this view. Comparatively small communities of Mohammedans live in the Chinese cities, their religious life centers round the mosque, they have their own clerical caste and their own religious tenets, of a completely different character from those of the heathen populace among whom they find themselves. In these respects the analogy is striking, and largely true. Another aspect however has probably not been sufficiently emphasized, namely that a racial as well as a religious distinction is made between Mohammedans and other Chinese. When the name of Republic was given to China, a new flag was adopted, consisting of five colors typifying the five races of which China is composed, i.e. Chinese, Manchus, Mongols, Tibetans and Moslems, the government thereby demonstrating that it recognizes Moslems as belonging to a distinct race. This race-consciousness is also prevalent among the Mohammedans themselves. A pupil in a mission girls' school asked a Christian friend whether it were possible for one whose parents were Moslems to become a Christian. As a racial characteristic Islam entered and continues to enter, the land, by way of the Northwest from Central Asia and it is only where the impact of Western thought is felt in the East, that it is otherwise conceived.

Moslem units or parishes are found scattered throughout the vast area included in the Chinese Republic, and investigation has proved that Chinese Islam is closely united within itself, and against aggression from without. During the journey above mentioned I had opportunity to visit several Moslem centers in North China, and then

made a rapid journey to Hankow. I was surprised to find on arrival, that rumor of my coming had preceded me to that place, and that my visit was expected by the ahungs. The following is an interesting illustration of the swiftness with which news relating to themselves is transmitted from community to community — When Dr. Zwemer was in Honan his visit was reported in Kansu, and the faithful were warned against this dangerous enemy!

The manner in which the Moslems unite to prevent secession to Christianity is also remarkable. A somewhat unsatisfactory Moslem in one Northern district, became an equally unsatisfactory Christian. So strong was local feeling that it was threatened to burn the mission compound of the town, should the man continue in his profession of Christianity. Similar cases could be multiplied.

A Moslem General Advance Movement was founded in Peking in 1911. Within a few years it had no less than two to three thousand branches throughout the country. It is somewhat difficult to know whether this is a cause or an illustration of the present unity of Chinese Islam. It is probably the latter, for the real causes lie deeper.

Islam and Idolatry First may be mentioned the essential difference between Islam and the idolatrous religions of China. Much has been said of the influence of Confucianism on Islam. But one must ever bear in mind that whatever superficial modifications Mohammedanism may have undergone in China, it is still primarily and essentially Islam. The religious difference of outlook knits every Moslem to his brother Moslem against the infidel beliefs of these pork-eating sons of Han. The social cleavage between Mohammedan and Pagan results in certain trades coming largely into the hands of Moslems. The trade in sheepskins in Shantung is practically their monopoly. The curio-dealers of Anking are nearly all Moslems. So are the chair-bearers who carry pilgrims up the sacred Tai Shan.

Organization There is further the essential similarity of each Mohammedan parish to its counterpart in any other place. Each one has its recognized leaders or "District Elders" who elect their own Imam (who in

China is generally responsible for the business affairs connected with the mosque) and muezzin. These in consultation invite an ahung, often from another district, to become the "Ahung who opens schools." This man acts as pastor and theological instructor and often brings with him several students who assist in the conduct of minor ceremonials connected with births, marriages and burials. Such is the organization throughout China and its very similarity is a strong binding power. For wherever the Moslem travels he finds such parishes and feels himself at home immediately, even apart from the fact that the members of the community all hold the same beliefs as himself.

Again the power of the ahung class is a factor which binds the various communities together. The laity openly profess ignorance of the content of their faith. Again and again in widely separated parts of the country laymen have said to me, when brought face to face with the need for a salvation not provided by their religion "We do not understand these things, but our ahungs know." One man added, "We expect them to lead us in the heavenly road, we can only follow blindly." A class of man grossly ignorant of all but the narrow system of doctrine and ceremonial that gives to them their power, is bound to do all possible to maintain that power, by allowing no one over whom it is exercised to stray beyond its limits.

Moslem
Travelers

There remains yet another factor that goes towards welding the Islam of China into an organic whole. The Mohammedans are of a considerably more enterprising spirit than their fellow countrymen of other religions, and this fact has its expression in the proportionally larger number of them who travel. There is a constant movement not only throughout the districts in which large communities are found, but across the length and breadth of the land, from Kashgar to Shanghai, and from Peking to Yunnan. In accordance with the demands of his religion, in every place along the main caravan routes, Moslem inns, restaurants and mosques are to be found. In Hankow the mosques themselves are fitted for the entertainment of guests. There are couches in the bath-houses, tables and chairs in the rooms attached

to them, one end of the very prayer hall itself of one mosque has the appearance of a small clubroom. The same is true of Shanghai, where I have met Moslem travelers from Kansu and Shensi. It will be readily understood what a power this constant movement is in binding together all the scattered units of Islam. The principal travellers are of three kinds—the merchant trading sheep, wolf and fox skins from Kansu and Tibet, who brings with him the sterner Mohammedanism of his home, which is an incentive to spur on his laxer co-religionists of the East to stricter observance of the commands of their faith. Then there are from fifty to one hundred pilgrims going every year to Mecca, for the most part from the West of China. Formerly the journey was made by way of Central Asia, through Persia, and consumed the better part of two years. But improved methods of transport have changed the route, and the pilgrims now travel by sea. The zeal of outgoing pilgrims, and the fresh ideas with which they return, are both conducive to revival and cohesion.

The third type of traveler are the ahungs in charge of the mosques. These are often “called” from far-distant districts. Throughout Kansu, Shensi and Szechwan, ahungs from Hochow in West Kansu are to be found holding office. An ahung met in Changteh, Hunan was a native of Yunnan and had held office in Canton. In the same city was another who had studied in Kansu.

Propaganda Occasionally I came across the tracks of Moslems from Turkestan and India who had done some propaganda in widely separated parts of China. But it would seem that the effect of such visits has been over-estimated. Usually the men were considered rather heretical and in one instance at least their books had been publicly burned.

Schisms The foregoing will suffice to indicate some of the causes for the existence of a unity among Chinese Moslems which has not been fully recognized hitherto. It will be noticed that union is organic rather than organized, and does not depend on any recognized central authority or formulated cohesion, between mosque and mosque, community and community. At the same

time the obverse of the picture must be recognized. The same schisms and rifts that one learns to connect with Islam everywhere are also to be found in China. D'Ollone has pointed out the almost complete isolation of the mosque-parishes from each other. But not much emphasis can be laid on this admitted fact, for as indicated above, the union that exists does not depend on ecclesiastical centralization of authority. Of far greater importance are the sects that divide and subdivide Chinese Mohammedanism into innumerable more or less hostile factions. There has not yet been sufficient investigation of this subject to make any authoritative pronouncement. Suffice it to say, that the recognized division into "Old" and "New" Sect is quite inadequate. Indeed it is almost impossible to discover which of the numerous recent manifestations are in the "New Sect." One mystical sect interested me greatly. It is known as the Djheriya (or Djherinya). The leader lives in Kansu. His followers are found in Manchuria, Chihli, Shantung, Kiangsu, Kweichow, Yunnan and probably other provinces. Everywhere they are spoken of as the most despicable heretics by the more orthodox sects. I was always received with the utmost friendliness by them. In Peking one of their ahungs said to me in effect, "We are condemned as heretics, but we feel with you that if man is to come to God, there must be the MAN who will lead us to Him." Verily a vast departure from orthodoxy, and one not unfraught with promise!

Throughout Northern and Central China, I found tombs of Moslem saints, each one a center of pilgrimage, and each group of earnest pilgrims constituting another sect in potentiality, and sometimes in fact. These tombs from one point of view form a connecting link between communities in different parts of the country, and at the same time embody and typify a schism in the camp of Islam—a contradiction strange but easily understood.

Modern Movements The impact of modern thought is producing results, the tendency of which is to cause a breaking away from orthodox Chinese Mohammedanism. In one center three brothers have all broken away from the faith of their fathers because they felt that Islam was unable to meet the demands of modern life. In

another town two brothers have confessed their belief in Christianity and opened a school in which it is taught. Attempts have been made to meet the "tide of modern thought" by means of education and general literature, some of it definitely anti-Christian. But although in some centers notably in the northwest, schools of primary grade have been founded and are carried on with some success, attempts at higher education have failed completely, and in the case of such students as I have met, it seems rather the "race-consciousness" before mentioned, than any strong religious convictions, that holds them true to their religion.

From what has been recorded of the General Forward Movement, it might be imagined to be a rather successful power, revivifying and reuniting the Mohammedanism of China. Without denying some truth in this view it should however be realized that in a large number of instances it has been a partial or complete failure. I have seen the name of the movement placed conspicuously over doors of mosques in which its activities had produced no results and had long since ceased. In one town was an ambitious notice of a bookroom opened under its auspices to which all were invited; on entering I found closed doors, thick dust, and broken windows, with no sign of books or papers or any living thing.

Evangelization In closing one cannot but make some reference to the missionary attitude and responsibility towards the whole question of the evangelization of Chinese Moslems. It was with not a little disappointment that I found an almost complete absence of sustained interest in this problem in all the centers visited, with a very few notable exceptions. Some of those whose names we had long connected with sterling work done for our Moslem friends, had been called to Higher Service, and no one had stepped forward to fill the gap. Some have retired. Others were on furlough and will no doubt soon return. The reasons for the lack of active useful interest are not difficult to find. The claims of missionary work on any sincere man or woman are many and various, and this one form has many peculiar difficulties which tend to its neglect. In some centers one found complete, one might almost say studied, indifference. One missionary in a

center where there were two or three thousand families of Mohammedans claimed that they were quite adequately reached by ordinary methods, such as are used for the heathen; in that center there were precisely two ex-Moslem Christians one of whom had been converted elsewhere. Another missionary treated the whole idea of special work for Moslems with open contempt, as a freak fad that was unworthy serious consideration. Moreover much of the literature prepared by the Committee on Work for Moslems is lying idle, orders for it being limited to some half dozen persons.

It surely should be unnecessary to have to urge upon those who are Heralds of the Gospel of Salvation the claims of some nine million souls, who constitute a widely scattered, largely united, distinctly anti-Christian force that is using every means within its power, from open persecution to boycott, to prevent its adherents from receiving the benefits of the Gospel; and that shows by its very divisions and failures that the time is ripe for an organized advance upon it by the Christian Church.

I would venture to appeal most earnestly to all Christian readers to pray that the Church as a whole, and each one of us individually may realize our responsibility, and that effective methods may be discovered and used, the result of which will be the liberation from the thraldom of Islam of many darkened souls.

CHAPTER XII

CHRISTIAN WORK AMONG CHINESE MOSLEMS

Isaac Mason

Number Working There are probably eight millions of Chinese Moslems scattered throughout the country, but the efforts put forth to reach them with the Christian evangel are disappointingly few. The present writer has never heard of any work undertaken by Roman Catholics for Moslems, and only about one in a thousand of the Protestant missionaries in China can be regarded as being set apart definitely for work among them. Probably not more than a dozen missionaries are giving serious attention to Moslems, whereas at least a hundred should be doing so, in view of the proportion of Mohammedans to the total population. Many missionaries come in contact with Moslems among the general population, and some distribute the special literature which has been prepared, and in other ways seek to influence them.

In Kansu, medical and other work specially intended to benefit Moslems is undertaken, and a few missionaries in that province are studying the problems, and seeking to make contacts: but such work is still in the elementary stages. The death, during 1923, of Mr. M. E. Botham, has removed a devoted and able missionary to Moslems, who is sorely missed.

Greater Effort Needed Mr. F. H. Rhodes has worked quietly and steadily for many years, making contacts by correspondence, and by judicious intensive efforts for individuals, as well as in stimulating foreigners to more interest in the Moslems. Dr. S. M. Zwemer's visits to China a few years ago roused much interest, and a Committee on Work for Moslems was formed. This Committee has been instrumental in increasing the special literature for Moslems, but thus far it has not done much at the problem of evangelizing Islam's millions in China.

This problem, like many others, awaits a rising tide of faith which shall bring in the workers and the funds necessary for an effort commensurate with the needs. Until the Churches, Chinese and foreign, awake to the responsibilities and the opportunities of the Moslem situation in China, the Committee appointed will find it difficult to do very much. Quite recently a travelling Secretary has been appointed, and it is hoped that a forward movement may soon be possible. There are many important centers where organized work should be undertaken. The argument sometimes heard, that such work is hopeless, should not be allowed undue weight; it is being disproved in all Mohammedan lands, and also in China at times. No record exists as to the number of Moslems in this land who have become Christians, but such conversions do take place. We know at least two valued Christian pastors who were formerly Moslems. While it remains true that in China Mohammedans are more approachable and more friendly than in other countries, yet it is difficult for a Moslem to change his religion; the traditions of the past, and the strong influences of family and friends, make it hard to change openly, even where there has been conviction of the Truth.

Literature

In Christian work for Moslems, the use of suitable literature is of great importance. In China we are now, fortunately, in a better position than ever before in the matter of literature; there are no less than 60 titles of Christian books and tracts which have been prepared for believers in Islam. Many of these books pay no attention to the special terminology used by Moslems, but within the last few years a number of books have been prepared which use such terms, and more is contemplated along this line. The B. and F. B. S. has issued some attractive Gospels and other portions of Scripture in Chinese and Arabic. Most of the books available are very small ones, and there is need for larger works. The problem is how to get the literature into the hands of those for whom it is intended, and here coöperation of missionaries is urgently needed; thus far the requests for literature have been utterly inadequate.

A large number of Chinese Moslem men can read, and they are usually glad to have gifts of books, and when these are given with discretion, they may be of immense help in preparing the ground. But personal contact and friendship offer the best hope of influencing our Moslem friends; arguments are of little use, and if they lead to disputes they are harmful. Love and forbearance, and patience and tact, are valuable at all times, and they are indispensable in all Christian work for Moslems.

PART III
THE CHURCH IN CHINA
CHAPTER XIII

PROGRESS AND PROBLEMS OF THE CHRISTIAN
MOVEMENT SINCE THE REVOLUTION (1911)

Edwin Marx

Within the limits of this article all that can be done with the subject is to summarize the results of study and present the salient conclusions. The sources of information have been books and periodicals dealing with the general history of the period; general missionary publications of the time; files of the China Mission Year Book, and of the Chinese Recorder; the Survey Volume (Christian Occupation of China), and records of the National Christian Conference; and, finally, correspondence with Christian workers in various parts of China.

The dark side of China's history since the inauguration of the republic is well known. Her problems, failures, shame and sorrows have been proclaimed to the world: ignorance, poverty, official corruption, social evils, militarism, lawlessness, internal strife and external pressure; "to cap all, floods, famines, and plagues to add to the distress and perplexities of the people." No one can ignore or minimize these sinister facts. However, the forces of evil and havoc have been matched with constructive influences which, if not yet predominant, are making headway. There are unmistakable signs of new life welling up, of new branches shooting out of the old stem. Space permits only to hint at a few; such as language reform, the literary movement, the feminist movement, growth of the press (practically all since 1911), experiments in modern and better city government, rising self-consciousness of labor, growth of public opinion,

development of education, creation of industries, extension of self government, growth of Chinese leadership, and a new intellectual awakening. The outcome of the efforts for improvement is not in doubt if the forces of progress do not waver or weaken. The sky is dark enough, but it is streaked with light — the light of dawn, not of sunset — and one of the rays is the Christian movement in China.¹

I. THE CHRISTIAN MOVEMENT²

The Christian movement may be said to include all the forces and influences in any way contributing to propagate in this nation the life of God as revealed in Jesus Christ. In the beginning this had to be done through the efforts of foreign missionaries. These have been reinforced, ever since the first convert was won, by the increasing body of Christian Chinese. There are other influences assisting the progress of the Christian movement, such as the general advancement of knowledge and communications with the west, although these latter influences have also their retarding effects. These various factors are in some ways separate, with distinct sets of problems and lines of progress. The foreign mission organizations, integral as their share has been in the Christian movement, are not the whole of the movement; and in the ratio that their offices have been well performed they will bulk less and less in the future. The Christian Chinese community, "the Chinese Church," has come to self-consciousness and is destined to develop more and more, until it can decisively dispense with its *paedagogue*, the foreign mission body. As yet, however, the Chinese Church, even should it be regarded as having arrived at full maturity, is not the whole of the Christian movement in China, and to assume that it is and act on that assumption would invite disaster. Christ's kingdom embraces many constituent parts and, axiomatically, is greater than any of them. The Christian movement has not so nearly attained its final goal in this country, nor indeed in any country, that it can dispense with a single possible ally. Its spirit and fellowship should be as comprehensive as the heart of its Leader, who counted among his helpers all that were not against Him.

II. PROGRESS.

After the birth of the republic, it was widely asserted that the Christian movement did more than any other single force to prepare the way for the revolution and to make possible its successful consummation; and reciprocally that the revolution brightened the prospects of the Christian movement.³ At the end of 1923 Christianity was pronounced the most steady factor and the most optimistic feature in the total situation in China.⁴ Between these two points of time, lies more than a decade of steady achievement. The progress may be traced along the following lines.

1. *Numerical Growth.*⁵ The number of communicants increased from 207,747 in 1913, to 366,000 in 1920, an average of more than 6% annually. At the same ratio, the number is now well above 400,000, thus doubling the membership since the beginning of the republic. Aside from members added to the Church, there has been a remarkable growth in reaching adherents. Sunday schools increased twice as fast as communicants, or about 12% annually from 1914 to 1920. From 1906 to 1920 communicants increased 105%, students in Christian schools 332%. During the last two years the movement has established contacts of great potentiality with three special groups,⁶ students (noted in the World Student Christian Conference in Peking); laborers, through the interest of the church in industrial problems; and to a less extent with political leaders.

2. *Leadership.* In 1913 the number of missionaries in China was approximately 5,565,⁷ and in 1923 it was 7,820,⁸ an average yearly increase of about 4%. During the war about 350 new missionaries a year entered China. This numerical growth has not yet stopped, though it is slowing down, due to the conviction that the need for rapid extension of foreign workers is past. In the future the numbers will be limited, with insistence on the highest standards of qualification and training.⁹ The increase in Chinese workers has been amazing. In 1907 the Chinese salaried workers outnumbered the foreign workers 2 to 1; in 1913, 3 to 1; and in 1922, the last figures we have, the ratio was 6 to 1. In seven years

preceding the conference of 1922, while the missionary force increased 25%, the Chinese force increased 95%. Evidence could be presented to show that these Chinese workers have developed in spiritual apprehension and in general ability to discharge their responsibilities, quite as truly as they have been augmented in numbers.¹⁰ "The reaction of the Christian teaching and experience on the Chinese gifts and character is producing men and women who stand beside any in the world".¹¹

3. *Domestication.*¹² Each year has seen Christianity striking firmer roots into the Chinese soil and being recognized as a permanent addition to the landscape. It is no longer, as formerly, unknown or ignored. Among its known members are officials and gentry all over the country, and individuals of national prominence. The patriotism of Christians as such is not now impugned. The atmosphere of Christianity begins to permeate the nation, and in every phase of life is exerting influence out of all proportion to its small part in the total population. The Christian Church has an acknowledged position, and is now recognized as not antagonistic to Chinese life, thought, customs, ideals and interests. It has its adversaries, but the most active ones resist it not on the ground that it is alien, but because they are opposed to all religion. There are protests against its western dress, but not professedly against its essential message. Christianity may be said to have become domesticated in China. References are beginning to be made to "the four religions of China." One writer who is in a good position to know declares that the other religions are beginning to fear Christianity will usurp the place previously occupied by them.¹³ In 1922 the center of gravity of the movement was shifted from the missions and foreign Christian workers to the churches and the Christian Chinese.¹⁴ Christianity has obtained a strategic position in China. This does not mean that the movement has no further obstacles. It has! But they are the impediments that Christianity meets everywhere, "the world, the flesh and the devil," . . . indifference, selfishness, sin in its myriad forms, . . . rather than the hostility formerly directed against it as exotic.

4. *Deepening Spiritual Life.*¹⁵ There is abundant testimony that those in China professing the Christian faith have secured a firm grasp on its essential meaning, and have acquired a real personal experience of it. The message issued by the Chinese at the Conference of 1922 was characterized by "concentration on big essentials, deep reverence, strong facing of the larger issues of the time, and demand for unity and courage in handling them." The same witness who thus described the message said further: "The hope of the church is not merely in the ability, nor even in the moral character of its leaders. It is in the fact that there are many people, often quite ordinary people, who have themselves come into a personal knowledge of God through Jesus Christ . . . Now I can say after spending a year and a half in fairly continuous travel here, that I have repeatedly met men and women who show the mark of such a personal experience. They are not copies, they are the real thing." The Christian experience with them is not merely a passive acceptance of teaching or emotion, but a strong desire is manifested for applying the principles of Christ to the problems of life:¹⁶ for establishing schools, hospitals, Red-Cross work, famine and flood relief and prevention. True, their energy and strength in these lines may not seem great if measured by Western standards, but the stream of activity is taking the right direction, and its volume will increase. Christians have coöperated heartily in movements against opium, alcohol, lotteries, gambling, and commercialized vice. They have assisted to develop play grounds, reading rooms, hygienic lectures, and institutional and community churches. They have given support to creating and maintaining new moral standards in regard to the home, business, politics, international relations, in fact in every relation that touches the life of the people. "A new religious climate is being produced, a different religious atmosphere is being created, and this cannot be described in tables of figures."¹⁷

5. *Coöperation and Unity.* A study of "Progress of Church Union and Coöperation in China," based on a study of the Survey Volume and reports of the five commissions

to the National Christian Conference, 1922, was made and published a few months ago.¹⁸ The conclusion was summed up thus:

“To one who believes in Church Union, this study has brought disappointment. The conclusion of it may be put in one sentence thus: the last fifteen to twenty years in China show much progress in coöperation on specific tasks, especially educational; less progress in more general Church coöperation; and very little progress in real Church Union. Beside the China facts of achievement or its absence, as found in the Survey Volume, there are also hopes, longings, and purposes. These too enter into the present situation. Some have been put into deliberate and significant statement. This sort of material is found abundantly in the Commission Reports and elsewhere. It is valuable for our study, and it is hopeful for further progress.”

In addition to the above, three specific manifestations of growing unity may be pointed out. (a) The relations of the foreign missionaries with the Chinese Church during the period of the republic, involving as they have constant readjustments, increasing recognition of the Chinese churches with corresponding retirement of the missionaries from positions of control to positions of advisers and helpers; relations fraught with constant possibilities of friction and misunderstanding, due to international as well as local causes; . . . these relations have continued on the whole most fraternal and agreeable, and have every promise of so continuing.¹⁹ (b) Nation-wide Christian surveys; and (c) the National Christian Conference, and establishment of the National Christian Council.²⁰ During 1922 four outstanding events focused the attention of the world on China, and all were manifestations of the unified Christian movement. They were the publication of the Survey Volume;²¹ the World Student Christian Federation Conference;²² the National Christian Conference; and the Survey of Christian Education²³ by a special Commission representing “the Mission Boards and Societies conducting work in China.”

III. PROBLEMS

Encouraging as are all the lines of progress noted above, they are only the roads along which the Christian movement is traveling. It has not yet arrived at the terminus of any one of them, and at every step lurks the possibility of the road suddenly stopping or branching off into a devious by-way.

Excellent as the numerical growth has been, it has yet to reach 999 out of every thousand of the population. Splendid as the response to the call for workers has been, yet over 90% of the Survey correspondents testified that the inadequacy of the occupation of their fields is due to the insufficient supply of Chinese workers.²⁴ There remain vast unoccupied (even if officially "claimed") areas, and untouched masses of the people, including nearly all of the rural 80% of the population.²⁵ The Christian movement is confronted with gigantic challenges, which if not accepted and carried off victoriously will finally defeat or neutralize the movement. Some of these are challenges growing out of its own life needs: How to promote self-reliance, both financial and spiritual; how to emphasize more adequately work by and for women;²⁶ how to develop a Christian literature that is of, by and for the Chinese people;²⁷ how to deepen the spiritual life of the Christian community, . . . that is, how to promote stewardship, Bible and other devotional reading, and in fact to evolve to a higher level the whole system of religious nurture that shall produce all the fruits of the Spirit, all the virtues and graces of Christian character. Other challenges to the movement grow out of the needs of the society of which it is part. It should engage as in a life and death struggle to help Chinese society meet the possibilities and dangers connected with the new industrial development;²⁸ to deal with the complicated problems arising from the changing family life,²⁹ as well as from the passing of some ethical standards and the coming of others;³⁰ to combat the menace of vice³¹ and drug³² traffics and the socialized cancers, such as gambling, bribery, polygamy and concubinage, that gnaw at the vitals of the nation.

However, it is not these challenges that most threaten the movement. The direction of duty with respect to them is fairly clear, and the whole movement can proceed in that direction unitedly, even if through toil and sweat, fire or flood. They appear as heroic tasks to be accomplished, where the whole force can apply itself with single purpose, and where failure or adversity encountered together does not weaken but strengthens the *esprit de corps*. The more critical situations arise where the way of duty or expedience is not clear; the consequence of which may be division of counsel, confusion of practise, or even deflection of the entire movement into a wrong course. The most conspicuous examples of this type now before the Christian movement, and the crux of each appear to be as stated below. Some would add to the list the relations between Chinese and foreign workers. But that matter seems to have taken care of itself fairly well hitherto, as indicated before; and we see no good reason for anticipating a different trend. It is one of the lines to progress to be *maintained*.

1. Influence of the New National Spirit.³³ It is inevitable and certainly proper and desirable that the appearance of better internal conditions and signs of progress should arouse in the Chinese people ever growing pride in their civilization and all things pertaining thereto. The process is now going on. The point to safeguard is: will the Christian movement in the face of the rising tide of nationalism maintain its catholic spirit and its universal outlook? China can from her spiritual heritage and genius make a noble contribution to the interpretation of the Christian religion, by which the Church universal will be enriched. But this will hardly be done if the spirit of nationalism should beget a narrow and proprietary attitude toward the Christian Church within her borders. The world is surfeited with "national" religions. The present age cries for faiths and attitudes that transcend national boundaries. The assumption that the gospel or any part of it belongs to any group less than universal . . . whether a denomination, a nation, a race or a hemisphere . . . to do with as it lists is a pernicious fallacy. The need of our time is not for more adjectives

to qualify the noun Christian, but for the adjective Christian to be prefixed to more nouns; not Chinese Christians, but Christian Chinese. The Christian movement must take possession of the nation, not the nation take possession of the movement. The appeal to the Christians of China is not to emulate the nations of the West, much less to retaliate upon them, but to excel them in this respect.

2. *The Naturalization of Christianity in China.*³⁴ By this is meant the assimilation of Christianity by Chinese life and thought; "a Christianity that has possession of the Chinese spirit and expresses itself in Chinese fashion"; "an interpretation of Christianity by the people of the country through statements of doctrine, through ceremonial forms, through architecture and music, which are the result of their own experience rather than taught them by the leaders from the West." If any foreigner questions the right or the need of such interpretation, he should go to a denomination other than his own and see how congenial he finds it. Will Greek and Roman Catholic, or Catholic and Protestant, or within the latter lines Baptist and Anglican, interchangeably declare each other's forms and statements sufficiently satisfying? If the Westerner himself will not bear these different yokes manufactured by other men of his own racial stock, and in some cases of his own nationality, how can he expect the Chinese (with natural temperament and spiritual inheritance more widely divergent from the West than those Western groups are from each other, assuming that such is the case), to be satisfied with the Western interpretations? "An interpretation of Christianity by the people of the country" there should be and must be. Yet, this is fraught with hazard to the Christian movement. It is one of China's boasts that she is a sea which salts every stream flowing into it. Will this Life-Giving Stream perhaps be transformed into a polluted and stagnant marsh, even as it has some times in the West? Or, to change the comparison: many Chinese express the wish, quite legitimately, to free the Christ from his Western garb, and present him in apparel more appropriate for China. If they will do this and leave him clothed only in His own simple, seamless robe, fit for every age and clime,

the whole world will acclaim the achievement with reverent gratitude. Cannot China here again excel the West, and after relieving Jesus of his Western regalia, spare Him the ordeal of being tricked out in mandarin garments ?

3. *Too much emphasis on the intellectual expression and the institutional features of Christianity, rather than on the creation of new life in the believers.* Christianity is primarily a way of life. Life, at least as we know it on this planet, does not function apart from concrete embodiment; hence some form of institution is indispensable. But life is ever greater than scientific statements about it, or the vessel which contains it, and the latter must never usurp the sole nor the primary place of solicitude. But to do and to say is so much easier than to be; and it is so much easier for "leadership" to perform in the realm of organization—that is, by ruling or directing—than in the sphere of humble service and spiritual attainment! Perhaps this is precisely a point at which the East will make one of its most helpful contributions in the interpretation of Christianity to the world.

REFERENCES

NCC : The Chinese Church, 1922, National Christian Council.

IRM : International Review of Missions.

YB : China Mission Year Book.

CR : Chinese Recorder.

FMC : Foreign Missions Conference of North America — Report.

- (1) For general situation, see: NCC 161-173; YB 1912-1923 inclusive; IRM Jan. 1922, 3-29; CR Dec. 1923, 701-708; Jan. 1924, 1-8. For Renaissance, New China: NCC 156-161; CR Aug. 1923, all; Apr. 1921, 257-267; May 1921, 303-323.
- (2) The Christian Movement: NCC 30-38; 177-242; 675-683; FMC 1923, 200-210; CR Sept. 1923, 503-510; Oct. 1920, 704-709; Dec. 1920, 851-856; Jan. 1920, 9-12.
- (3) YB 1912, 96-112.
- (4) CR Nov. 1923, 633 and 698.
- (5) NCC 144-147.
- (6) CR Jan. 1923, 4-5.
- (7) YB 1916, 1.
- (8) (9) CR Sept. 1923, 505.
- (10) NCC 179, 220.
- (11) CR Jan 1923, 35.
- (12) YB 1912, 25; 1913, 40 and 116-136; 1915, 31-35; 1923, 12-17, and 66-69; NCC 134, 603; CR Jan. 1921, 6; Jan. 1923, 3; IRM Jan. 1922, 13; CR Dec. 1923, 708.
- (13) CR Nov. 1923, 673.
- (14) CR Jan. 1923, 8.
- (15) CR Jan. 1923, 7; NCC 138-142.
- (16) CR Jan. 1923, 35; Dec. 1923, 708; YB 1912, 25; IRM Jan. 1922, 22. NCC 146.
- (17) IRM Jan. 1922, 16.
- (18) CR Sept. 1923, 511-520.
- (19) YB 1915, 33; IRM Jan. 1922, 24-25.

- (20) NCC, contents; YB 1923, 54-65; on Nat. Chr. Coun. espec. NCC 635-74.
- (21) NCC 41-77, esp. 64; YB 1923, 34-41.
- (22) YB 1923, 315-317.
- (23) YB 1923, 155-165; NCC 65; "Christian Education in China," Report.
- (24) NCC 221.
- (25) CR Oct. 1920, 696-700; Feb. 1923, 100-102; Apr. 1923, 231-232; NCC 360-365.
- (26) NCC 137; YB 1915, 33; NCC 240-242.
- (27) NCC 411-461; CR Dec. 1923, 713-718; China Bookman, Dec. 1923, 3-16.
- (28) NCC 323-339, 461-471; YB 1923, 18-29, 225-235; CR Dec. 1923, 737-739. CR Dec. 1920, 826-837.
- (29) CR Aug. 1923, 439; Sept. 1923, 564; Dec. 1923, 709-712; Jan. 1924, 24-27.
- (30) NCC 339-346; 472-479; YB 1923, 260-270; CR Aug. 1920, 524-525; CR Nov. 1923, 631; Jan. 1921, 3-4.
- (31) YB 1923, 236-241. (32) YB 1923, 216-224.
- (33) CR Jan. 1921, 4-7; July 1923, 391-396; Aug. 1923, 456-459; Nov. 1923, 634-636; FMC 1919, 188-212; 1922, 88-141.
- (34) NCC 246-251, 495-534, 664-674; CR Sept. 1920, 628-630; 636-639; Nov. 1920, 768-772; Dec. 1920, 817-818; Aug. 1923, 443-444, 445-446; Dec. 1923, 705-707; Jan. 1924, 38-39, 57-58. YB 1915, 34; 1923, 56-57.

CHAPTER XIV

RECENT DEVELOPMENTS IN CHINESE CHURCH LIFE

I. West China.

Szechwan
Christian
Council

In the province of Szechwan itself probably the most important movement within the Chinese churches during the past year was the organization of the Szechwan Christian Council. Since 1913 there has been an Advisory Council of the churches corresponding in a general way to the West China Mission Advisory Board. During the past year it has been reorganized as the Szechwan Christian Council with headquarters in Chengtu.

The objective of the S. C. C. is to develop methods of evangelism, to promote a spirit of coöperation and to foster friendly relations between the churches. It is composed of six representatives from each of the participating churches, two each from the Y. M. C. A. and the Y. W. C. A., one from the Bible Societies, three from the Union University and two from the Educational Union. All of the churches represented in the Advisory Board, except one, are at present represented in this body. The work of the former 'Province-wide Evangelistic Committee' was merged into the Evangelistic department of the S. C. C.

'City'
Christian
Councils

In harmony with a recommendation of the S. C. C. that where two or more Missions are at work in one city, local union Councils be formed, Kiating and Chengtu have fallen in line and organized 'city' Christian Councils.

Evangelistic
Campaigns

Special Evangelistic campaigns have been conducted during the year in a number of cities. The immediate results of these campaigns, conducted under the leadership of the Secretary of Evangelism, Rev. H. J. Openshaw, testify to their

intrinsic value, but from the standpoint of the development of Chinese leadership they have a particularly important significance. Each church represented on the S. C. C. releases one of its strongest Chinese preachers for a period of two months in the year to accompany the Secretary on his campaigns, visiting as a rule cities outside the sphere of the church to which the Chinese preacher in question belongs. Thus, under the most favorable conditions of association and work, a great interdenominational brotherhood of leaders is, we hope, developing.

Endowment Societies

One activity of the Chinese church, along financial lines, as evidenced in at least three of the churches, is seen in the establishment of 'endowment societies' for the purpose of furthering self-support. These societies are being organized for the support of hospital, educational and evangelistic work; in some cases quite large sums being raised. While some might question the spiritual value of the method, others point to it as an outstanding development of the year.

New Movements

Szechwan is not true to herself if not initiating something. During the year the new 'World Religion' or 'Six Religion Society' sprang up and through its drastic prophetic messages soon spread its influence through all China. Coming out as it did from the very midst of the Christian churches and accompanied by distracting political conditions, it profoundly influenced the thinking of the Christian groups throughout West China. That it weakened the faith of many goes without saying but on the whole the final effect was probably beneficial. It compelled the Christians to think, to put out tracts, to oppose something definite, and in church pulpit and street chapel to define both to themselves and the non-Christians, their real conception of Christianity.

Independence

Signs are not wanting here and there of independent churches springing up around strong Chinese leaders who for one reason or another think that Christianity should not center round the 'missionary' type of church alone. These apparently weak

beginnings of indigenous Christianity may eventually prove to be the most important of all developments.

Home Missions While the contributions of the West China churches to the missionary work of the Chinese church in Yunnan are probably small, denominational missionary developments are not lacking. The West China Baptist Chinese Convention has opened up work among the 'aborigines' to the South. Chinese missionaries have been sent in, the task surveyed, funds collected and preparations made for the full establishment of the work during the coming year. The Home Missionary Society of the church in connection with the Canadian Methodist Mission has added two women (Chinese) missionaries to the staff already at work among the 'hill tribes' to the west and has purchased a valuable property at Wei Chiu looking to expansion in that direction.

Union While efforts are still being made in some directions to foster the spirit of unity, and while the standard of inter-recognition of church membership between the churches is still in general being maintained, it would, nevertheless, be difficult to point to any new and specific development among the churches (or Missions) which might be interpreted as taking seriously the 1908 proposal of "One Protestant Christian Church for West China."

Student Volunteer Movement The Student Volunteer Movement within the student body of the West China Union University has shown special activity during the year. This was largely the result of sending three delegates to the National Conference at Kuling, 1922. There are about thirty members and they publish a Quarterly. The movement as such has unfortunately as yet no direct connection with the Chinese churches, though efforts have been made by the Christian Council towards linking them together.

Statistics Reporting for the Province of Szechwan only we find a total of 17,497 communicant members. In 1920 the total was 12,954, which allows for an increase of about 35% in three years. During 1922 the increase was 1,200, over 900 of which was within the

work of the Eastern section of the China Inland Mission; the balance of the 300 increase was divided among four churches, two societies reporting a decrease. In 1920 there were 30 ordained Chinese pastors; there are now 45, an increase of about 50% in three years.

School for the Blind A School for the Blind in West China has been on the program of Union activities for over ten years. Finally the American Baptist friends have undertaken the task and are running a school with an enrollment of 12 students in connection with their Social Service Club. It is opened to serve as far as possible the other churches in caring for this needy class.

Conditions As illustrating the conditions which handicapped campaign work and work in general during the year we might quote from a report in the West China News of the Union meetings at Chinese New Year in Chengtu. "The day after the meetings began the city was attacked and the city gates closed. More than one address was given to the accompaniment of machine gun and rifle bullets, while an occasional shell thrown into the city added variety." . . . "Under such circumstances to gather from 250 to 400 Christians together from all parts of the city every morning and hold a meeting for outsiders with an attendance ranging from 300 to 600 every afternoon is an achievement for which we may 'thank God and take courage.' Could it be done by any other organization except the Christian church?"

R. O. JOLIFFE

II. EAST CENTRAL CHINA

Progress Most of the churches in East Central China report favorable progress during 1923. There has been increased openness to the Christian appeal on the part of the people at large, and if there has been any anti-Christian propaganda it has been limited to the intellectuals and has not infrequently proved a spur to the Christian movement. This has proved the case in several government schools. The churches have kept well at their tasks, with

only a set-back here and there. North of the river and in parts of Chekiang, the churches have suffered with the common people from bandit raids but East Central China has, on the whole, suffered the least in such matters.

In Christian work it is still impossible to consider the work and life of the Chinese Church apart from the activities of the western workers. Except for various unrelated units the work is still done by the combined efforts of both Chinese and westerners. Some of the recent features of the church life in this section of China may be summarized as follows:

Community Church *There is a movement towards the institutional or "community" church. Attempts of all kinds are being made to relate the church life to certain needs of the community and in the larger cities such as Nanking, Soochow and Shanghai institutional churches have been erected in which the busiest time of day is the period between four in the afternoon and ten at night. Surveys and investigations, industrial work, community-centers, night classes, health campaigns, clubs for young men and women, dispensary work, vacation schools,— these and other activities are the order of the day. A new type of church worker is asked for, one trained not to hold preaching-hall meetings but to carry on social welfare work. Noted visitors from abroad have come to investigate the social conditions in Shanghai and other industrial centers of China, and mass meetings have been held to promote movements against evil factory and living conditions. Child-labor has been abolished in some factories as a result of the movement and other good results have been effected. During the summer a spirited conference on the "community church" was held in Shanghai and only the community church was held to be the "live" church.*

Self-Support *Special efforts have been made to maintain the work of the church with Chinese money. Several localities report churches erected entirely from funds raised by the Chinese Christians. Education in Christian stewardship has been promoted systematically in various missions and brought good results. Some attempts have been made to raise money through industrial ventures — not always with success. Church schools still prosper and often bring*

in enough money to maintain the work of the church. Self-support on the part of the mass of churches is still very far off and can only come when the Chinese people see the real value and importance of the Christian church. Progress is, however, being made.

Education *The churches are giving attention to elementary education.* This has two aspects: (1) the churches are working towards literacy among women. The phonetic has been used with success, especially in some country stations, but during the latter part of the year the popular movement towards learning at least one thousand of the most used Chinese characters seems to have supplanted the interest in phonetics in the larger cities. Nearly all the churches report attempts to teach illiterate women and children. (2) Attention is being given to the primary schools and efforts are being made to train up a better class of teacher and to organize and supervise the work. The higher educational centers are giving courses in the training and supervising of teachers and by the help of the East China Christian Educational Association a standard is being generally recognized for such primary school work.

Indigenous Church *The younger Chinese workers are talking much about the "indigenous church."* To some this has meant a desire for complete control of the church life by Chinese and a growing impatience with the western workers. To others it has meant the quiet acceptance of the responsibilities of church government and gospel propagation. The prominence of young Chinese in positions of leadership is noteworthy, as for instance, on the National Christian Council, on church boards and committees, in mission hospitals and in the general work of the church. The word "indigenous" is being used without clear definition. The more scholarly are pondering what the contribution of the Chinese mind and civilization to the Christian Church of the Ages really is or could be, but up to the present it may safely be said that no real contribution has been offered either to credal statement or to church polity. Some compromises in thought with Buddhism have been indulged in, but this seems to be regress rather than progress.

Missionary *The foreign workers are pondering more than ever their real contribution to the work in China and their relation to the growing native church. Many are making special effort to pass responsibilities over to the Chinese. Others have gone on about as before, but realizing more than ever that their aim must be to decrease while the native control increases.*

Coöperation *Increased willingness to coöperate with others is expressed by most churches. In Nanking a city Church Council has been organized for some years, but in Hangehow for the first time an effective organization of all the Christian activities in the city has been brought about. The churches express sympathy with the National Christian Council and welcome suggestions from it. The earthquake in Japan gave an excellent opportunity to the Chinese churches to show their brotherly spirit to the Japanese churches and the response was very satisfactory.*

W. P. ROBERTS

III. NORTH CHINA

Free from Disturbances *The year 1923 should go down in the records as one remarkably free from the disturbances which have hindered the work of preaching the Gospel for the last few years. The regular staff has not been turned aside from their preaching duties to serve tables on account of famine or flood, and the people have enough to eat as their harvest was a good one. Neither has there been any fighting on a large scale between the armies of the Chihli and Manchurian parties. These two things alone are a source of great thanksgiving, for the poor people no matter what may come in the future have had a chance to recuperate from past devastations. Because of the splendid work that was done in famine relief and in establishing safety zones after the war, and the way in which the work was carried on, the reputation of the church has been greatly enhanced among all classes, and the thinking public have come to realize more nearly what the purpose of the church is. It is not the old despised foreign institution. It is not the servant of the foreign governments that compelled obedience to its wishes with a*

threat of foreign intervention as was the idea after 1900, but it is an organ that is trying to help the best interests of the people in every walk of life.

While there have been no great wars, the country has been sadly afflicted with bandits and marauding soldiers, and in this general desolation which exists nearly all over China, with the exception of the province of Shansi, the church has been very seldom molested. There have been cases where missionaries and pastors have been carried off for ransom, but they are very few considering the fearful unrest.

**Spiritual
Needs** There has come during the last year in all of the churches a realization of the fact that the great need of the church in North China is a spiritual uplift. The fearful competition in business, the absolute loss of all ideals in politics and the craving for amusement that has spread all over the country has threatened to engulf the spiritual life of the new church in China, and there is a realization on all sides that these tides must be stemmed. The only hope of China is in the living, vital, Christ-filled church. The organization of a few foreigners or Chinese when not led by the Master himself is absolutely useless and will not aid in any way in stemming the present downward tendency. How is the spiritual life to be deepened? The answer is not far to seek. The missionaries and pastors must be willing to pay the price. It will not be brought about through committees nor campaigns, but only through agonizing prayer on the part of individuals and groups of individuals who will carry their newly acquired strength out into the larger life of the church. The living Christ is as willing to give his spirit to the church now as at any time in the past, and His power is sufficient for all even in the most trying circumstances of modern life, if we as a church are only willing to seek that power and to live the life He would have us live. There is need not so much for great campaigns as for intensive work among the present membership of the churches that they may understand their relation to God and their responsibilities as Christians to their families and their neighbors and go out to fulfill those responsibilities. The new tendency to give more of the administrative work

over to the Chinese will release some missionaries we hope, so they can devote all their time to developing the spiritual life in the church.

Christian Prestige In the days gone by when there was so much objection to Christianity the question of bringing people into the church for false motives was one not to be thought of among the better classes. But now there is a certain prestige about being a Christian in many quarters, and men will join the church who can pass any examination on the Bible that is set up for them, and still lack entirely the essence of Christianity. They can read and pray and sing, but do not know Christ, and after all that is the great demand for the Church at the present time. A new emphasis must be placed on the efforts of the church. The old churches which have been built simply to serve as meeting places once a week must be adapted to the present needs of the people or must be rebuilt so they can be open every day in the week to serve the people in a variety of ways. Following the example of the Salvation Army several large and well-built modern churches have been placed on some of the great streets of the city of Peking during the last year, and it will be interesting to see whether these modern buildings, adapted for a great variety of work, will be successful in developing a real living and working church more rapidly than the old type of building. They do attract a new class of listeners, and the fact that some of the leading officials in our great towns are now actively Christian is having a very marked effect on the feeling toward the church. We need to pray most earnestly that all of the men who have become Christians shall dare to show their colors on all occasions.

The institutional church has come to stay and is proving its popularity and success. Whether we have lectures on health or general subjects, or organize the members for work among the poor, or in clubs for boys and girls, they are well attended and there are sufficient people who are willing to help if they are properly directed. But there certainly is a need of highly trained Chinese and foreign specialists along this line.

**Supply of
Preachers**

The supply of preachers in North China is far from adequate. Although one of the leading theological seminaries has raised the standard to that of middle school graduates, even these men while they are able to cope with the situation in many country towns and villages will not be able to meet the situation in the cities, and there are not nearly enough of them to supply the demands. For the day has gone forever when a common servant or man with a lower primary school education can be trained in a few months to actually lead the people in spiritual things. The larger posts in the cities must be filled by the university theological school men. But how the four or five men who graduate each year can supply all of the present demands it is impossible to see. This problem needs the most earnest thought and prayer by all the workers in this area. There are countless opportunities everywhere, but the responsibility has shifted from the missionary to the young Chinese leaders. Will these young men who are graduating from our universities hear the call of the Lord Jesus to help their countrymen and will they be willing to pay the price of serving churches with rather difficult boards of deacons or stewards, or, when the situation becomes tense will they resign and satisfy their consciences with the fact that they have been driven from the hard work of the church to the more remunerative employment outside, by the church members themselves?

Self-support

The matter of self-support is one that must be solved. While the people are giving large sums of money for educational and medical work, they are not contributing like sums to the support of the church. On the other hand we are demanding a better class of pastor and he must be paid a very much higher wage as the necessities of life have increased at least 100% during the last six years. It is evident that while the people are getting under the educational and medical burden, they have not yet seen the vision of the self-supporting church as they should. Whether we would all turn to a voluntary ministry is a question that has been seriously discussed and has been tried out by some of the larger churches. What the result will be after a period of eight or ten years we are all earnestly waiting to see.

There seems to be an earnest determination that church members shall be better educated. Some of the large churches are insisting that all the membership shall be trained to read and write. In the city this is not a hard thing to bring about, but in the country if it were not for the new Chu Yin Tzu Mu it would be absolutely impossible. We find everywhere men and women who were absolutely hopeless as far as education was concerned now being able to read the Gospels without difficulty. But still the demand for the regular Chinese characters is very apparent and all who are able to learn it prefer the regular characters.

Student Work The special student work department in connection with the churches and the Y. M. C. A. in Peking has had another successful year, and has proved beyond doubt that this is the best way to solve the student work. One building has recently been erected especially for the work near the Higher Normal School, and the young men from that institution are taking a great interest in Bible Class work and other departments. It will be of interest to see this year when they have so much leisure on account of the failure of the government schools to run full time, if they will make the most of this opportunity to study the Christian life and to do Christian work. Up to the present time very few Christian workers have come from the government schools, but with the opportunity of working in the church from the time they first enter the government schools until they leave, there should be an entire change in this respect. The missions should be able to appoint a few able, consecrated men to so impress the young life of the government that they will be willing to devote their lives to this work as willingly as young men and women from the state universities of America.

On all sides the members and students are reading and studying as never before. There is a great demand for books, — books on philosophy and books on the modern situation. The Renaissance movement has certainly aroused an interest not only in Christianity but in all of the older religions of China, and it is probably true that the higher classes of China are studying Buddhism at the present time as never before. This is a fair challenge to

Christianity to enter the field with the best of modern literature and prove its worth. While the average missionary has not the time nor ability to prepare such books, the church must face these facts and the books must be prepared.

(GEORGE L. DAVIS.)

IV. FUKIEN

The territory covered by this report is the northern part of Fukien province.

Disturbances Every district sees its work with a background of bandits and soldiers, plunder and war. One writes;—"This year there has been almost constant requisition of load men, so that there has been very little traffic of any kind. Official demands for money have also been a great burden to the people. It is hard to picture the misery of the poor people. During July there was an unexpected outbreak of hostilities. Three battles took place in or near Yungan city. A number of people were killed and a section of the city burnt down. Looting was common. The loss suffered through fire and looting amounted to about \$200,000. Eight times in two weeks the people had to make heavy payments to the soldiers. The suffering was terrible. Some men were compelled to sell their wives; others their children to meet these extortions, while others committed suicide. The suffering caused by the soldiers has fully equalled that caused by the bandits.—The past year has been the worst since the beginning of the Republic."

Special Evangelism In spite of the above, in several places special evangelistic meetings have been held. Sometimes a campaign with carefully planned program, speakers and personal workers, as at Yenping and Futsing. In one place "over ninety men and one hundred and fifty women signed their names thus expressing their desire to learn more about Christianity." In another place over 10,000 heard the Gospel.

In other places the church leaders from several churches have gathered two or more times during the year

with each church in turn, and thus the whole district has been covered more than once during the year. This method has been used in Diong Loh.

In other places, notably Ing Tai, students have been used during the summer vacation to go into new villages. As a result at least ten large centers are calling in this one field for Christian workers, and they are offering to bear a large part of the expense if only the Christian workers can be found.

On Easter or on Christmas in Kienning and in Foochow the Christians have had a procession. At Easter they visited the graves and held family services. They distributed leaflets telling about the resurrection. At Christmas leaflets about Christmas were distributed. As the procession passed a Christian's house or a church, firecrackers announced the fact.

New Building In spite of the looting, burning and extortion, several centers report unprecedented advance in the building of churches, schools and social centers. The C. M. S. of Hing Hua reports;—"In material things there is more progress than in any time I can think of. Several churches are being built." The money has come almost entirely from the Chinese. Kutien reports:—"In three centers large new churches have been erected. In each case the enterprise was initiated by the local Chinese church members; all the funds were raised by them with no help whatever from the Missionary Societies, and very little from any foreign sources at all. The Chinese church members are beginning to take a share in the educational burden. In two centers they have built boarding schools for Higher Primary grade pupils, and are making themselves responsible for a greater part of the running expenses of these two new schools. "Much the same could be written of the Ing Tai field and of the Funing field. Yenping reports ten new churches, and other places less numbers. The material growth in church buildings and buildings for schools, hospitals and social centers is very gratifying. Is the spiritual growth keeping pace? One writer says; "I should say that real solid, spiritual work has been at a discount.

That is, there is no large number coming on for baptism or confirmation. Congregations of ordinary folk are smaller than usual, and the spiritual atmosphere seems lacking in power." I have watched the great expansion in land purchasing and in building by the missions here in north Fukien for the past decade with intense interest, and the spiritual is not keeping pace with the material. Is this inevitable? The reasons for the great increase in building this past year are (1) more contributions from the Chinese, (2) the lessened influence of the world war.

Devolution All speak of increased responsibility assumed by the Chinese in the departments of finance and administration and in a general interest in the success of Christianity in China. "The younger workers are definitely more willing to think in wider terms than the older and are more willing to take risks. They can picture the conception of a Chinese church in a way the older men don't wish to." From lack of men and money "the mission has had perforce to withdraw a good deal; the Chinese church rose to the occasion; she has not suffered at all; on the contrary, with the necessity of discovering her own powers and relying on her own resources, she has developed in a very marked degree."

Moral Welfare The Moral Welfare Association, an undertaking in which all the missions in Foochow co-operate, has for the first time engaged a full time Organizing Secretary, the Rev. Hu Ing-huang, a Methodist pastor. He began his work on Jan. 1st., and has been fully engaged ever since. He attended and spoke at the Preacher's Conference at Amoy, and afterwards visited among other places, the districts of Futsing Hinghua, Funing, Ningteh, Loyuan and Lienkong and branches of the Moral Welfare Association have been started in each of these centers. In most cases the co-operation of the local gentry has been secured.

The membership campaign of the Foochow Association resulted in the enrollment of some two thousand members, and the program against gambling, sexual vice, opium, wine and cigarettes was brought before the whole city. The Foochow press was most cordial in its help.

Opium The whole region has felt the insistence of the militarists to tax opium and to force the planting of the poppy. In one place the church leaders met on Saturday evening in special session and decided to try and stop the planting of the seed which had been distributed. Sunday morning an official proclamation was issued to the effect that the seed need not be planted. Not all places are as brave.

Methodist Jubilee The first missionaries of the Methodist Church North arrived in China and began work in Foochow September 1847. Their Jubilee was held in November 1923. Delegates were present from every one of the China Methodist Conferences and from Korea, Japan and America. Dr. H. H. Lowry of Peking was present. He came first to Foochow in the early days of mission work and went soon to help open the new station in Peking. His life in China almost covers the history of Methodism in China.

Church Union The Congregational churches in Foochow and in Shaowu have voted to become integral parts of the new church union, The CHURCH OF CHRIST IN CHINA. Last November and December the Foochow and Amoy branches of that church exchanged fraternal delegates for their Annual Conferences.

WILLARD L. BEARD.

V. SOUTH CHINA

Our subject assumes that there is development. This development is understood as progressive. It should also be noted that we are discussing, not individual Christian life, but the corporate life of the Chinese Christian Church.

Self-consciousness The most conspicuous and also the most important development of the Chinese Church life is a CONSCIOUSNESS THAT THE CHURCH IS CHINESE. With this 'consciousness' there is a certain amount of self-assertion as the Christians begin to realize that the Church is their very own. This is, of course, a sign of a healthy growth and should be

encouraged in every way. It is not in opposition — in any way—to those who planted the Church. On the contrary, those coming here from foreign lands are heartily welcomed as fellow workers when and if they work for the upbuilding of the Chinese Church — not the transplanting of the Church from the West. It is the feeling of a son in the home becoming of age and desiring to stand on his own account that they have.

This spirit of self-assertion manifests itself most conspicuously in the desire for SELF-GOVERNMENT. Time was, and not so very long ago, when all government as well as initiative and forward steps taken, were in the hands of, and led by, the foreign missionary. This is entirely changed now. Most of the church courts are being presided over by Chinese and no forward steps are being taken nowadays without the Chinese being in the lead. Not that the foreign missionary is discounted, but that the Chinese feel it is their right, their privilege, and their responsibility to take the lead.

The writer has in mind one church that was started entirely independent of foreign support or control, yet a foreign missionary was asked to sit with the church council as an adviser; the pulpit also is often occupied by a missionary. The idea of "China for the Chinese" has, however, taken firm hold of the Church, and must be recognized. To oppose it is futile if not wrong. If understood and done in a brotherly fashion there can be no harm in it; it is, on the contrary, fraught with the possibility of great good.

These things make one feel that the Church is in process of becoming INDIGENOUS. On this subject we desire to quote from an Editorial in the Jan. 1924 "Chinese Recorder."

"The 'Indigenous' Church is the China Christian's Castle in the air. For many years its glowing ramparts have gleamed afar. It is, therefore, no new subject of discussion. The past year has, however, registered widespread questioning as to what is really meant by the 'Indigenous Church.' That it stands for something that both the Chinese and the Western Christians want is generally agreed

Becoming
Indigenous

on. But they do not seem to want the same thing. Many Western Christians think of the 'Indigenous' Church as an Institution made up of Chinese, it is true, but conserving certain type elements in the Western Church of their experience. When the Western Christian is a strong denominationalist he is apt to think of the 'Indigenous' Church in China in terms of the supremacy of his type of church. Some Western church leaders at the home base are not sure that the 'Indigenous' Church should have as much freedom in development as some Chinese leaders are asking. Chinese Christians are not as articulate as their Western colleagues. The articulate Chinese group, though small, must be taken as representative of the present tendency of Chinese Christian thought and as indicating the direction of the thought of the mass of Chinese Christians when they have likewise become articulate. The articulate Chinese group asks for sufficient freedom to express its Christian life in Chinese thought form, and to some extent in Chinese symbols. None of them knows yet just what is needed. They are feeling their way. Those who are thinking into the problem have, during the past year, come more clearly against the fundamental difficulty in the establishment of the 'Indigenous' Church. This difficulty is the over-shadowing and overpowering influence of the diplomatic protection of Christianity in China, and the financial dependence of the Chinese Church on the generosity of the Western Christians. They do not know what to do. It has been stated by some Chinese Christian leaders that the expressed desire for an 'Indigenous' Church can be achieved only by the starting of a new type of Christian Church, that is, a Church from the foundation up really Chinese. No suggestion has come our way as to how this is to be secured. The hesitancy of the Chinese Christian to sacrifice self and means is said to be due, in part at least, to the chill cast on the Chinese Christian spirit of adventure by the shadow of the existing system of protection and support."

Self-assertion There is also a tendency to self assertion in the matter of *Theology*. The Chinese who said "I feel that ¹ I spent too much time in studying books written by Westerners about the Church and about Christ, and not enough in the study of Christ Himself" voiced the sentiment of many of the younger and aggressive Church leaders. Most of the old time preachers were only echos of their foreign missionary teachers—which was of course a very natural thing and not necessarily to their discredit. But now among the younger leaders there are those who are trying to interpret Christ from the standpoint of Chinese thought, or dressing the TRUTHS of the Gospel in Chinese ideas. One need not be too much concerned over this. The same "SPIRIT OF TRUTH" is leading the Chinese that led saints and scholars of the West to express these same truths in the thought of their own day.

Self-support There has been great development in SELF-SUPPORT. Every year the number of self-supporting Churches increases. This in spite too of the political disturbances of the past few years. The Southern Baptists have perhaps made the greatest advance along this line. In their Hakka Mission the Chinese Churches have organized a Home Board, for carrying on evangelistic work among the Hakka people, and a Board of Education for the care of day schools in connection with the chapels. A Sunday School Secretary is employed for the promotion of this work among the Churches. The middle schools for boys and girls in Canton are almost entirely independent of the mission.

The Church of Christ in China is making rapid strides towards self-support and self-propagation. It is entirely autonomous and self-governing. The annual observance of "Church Sunday" in which the work, its history and its glory is set forth is a great stimulus towards self-support. Contributions are annually made to the middle schools both for boys and for girls. Special scholarships have been subscribed for training young men in the Union Theological College. An effort is now being made to raise an

¹ See Chinese Recorder, January, 1924, page 8.

endowment fund of \$20,000 for the Union Theological College. This shows that the institutions started by the missions are considered by the Chinese as worth while and worthy of support.

CHURCH BUILDING has received a great deal of attention during recent years. Several new and up-to-date church edifices have been built. One church of the institution type, costing over \$70,000 Mex., has just been completed. A great deal of the money for these building projects has been gathered from Chinese abroad. As a rule the architecture used is the Western type.

Expressional Life There has been considerable development in the **EXPRESSIONAL ACTIVITIES** of the Chinese Church. This is indicated by joint efforts such as health campaigns, purity campaigns, and works of mercy, such as Red Cross work among the soldiers, and relief for destitute people in the war region. The Federated Churches in Canton have established a school for poor boys. A group of Christians has established an Old People's Home. The Baptist Church in Shiu Chow has organized an Orphanage. They also control a hospital in Ying Tak which was started by the mission. The Church is the recognized leader in reform as well as in works of mercy. Surveys of social and labor conditions are being undertaken and welfare work is considered a type of activity that the church should undertake.

Social Life With reference to the question as to how far the Church is influencing the social life of the Chinese several points should be mentioned as indicating tendencies.

First of all is the fact that non-Christians will often admit that there is something in the Church that is alive and "up and doing."

The observance of the Christian Sunday is making headway. Though this is one of the weak points in Kwangtung we can register progress made in the last few years. Whether or not Sabbath observance, as our fathers in the west knew it, will ever become a rule in China may be questioned. However this much may be said, that Sunday is more and more winning favor as a day of change and rest, not necessarily as one of religious observance.

Government offices and Government schools observe Sunday as a holiday. Many of the workshops are giving part holiday on Sunday, some give the entire day. The big department stores give a half day's holiday and also provide religious services. In the country churches spending a few hours in the Chapel is considered as “keeping the Sabbath.”

In some instances the Church has taken the place of the Ancestral Hall which is the center of all village, social, political and religious life. While these cases are few in number they show what may happen in the future when we shall see clans as a whole coming into the Church.

“Native Color” The Chinese Church is taking on “Native color”. In this we rejoice for it is the crowning glory of the mission. There have been real progress and development and we believe, on the whole, along the right lines. What a grand institution the Chinese Church may become! The churches of the west, the south and the north have given China their richest gifts. The Chinese Church can choose the best of each and mould it into one complete whole, which may yet become the model for the Church Universal. I believe the Chinese Church desires, not to stand aloof from the churches of other nationalities, but to take her rightful place among them. The Chinese Church is a vital organ for the regeneration of the social life of the Chinese, because of the Spirit of God which is in her and because of “the one foundation” on which she is built. May she glorify him who for her life died, until the day when she shall be presented before God “without spot or blemish or any such thing.”

A. J. FISHER.

VI WU-HAN

Political Disturbances North and south of the center and throughout the country districts, the life of the people has been much disturbed by the movement of armies and by the destruction wrought by bandits. The three central cities of Hankow, Hanyang and Wuchang have, however, been free from disturbance and alarm.

The political conditions throughout the country have caused a greater seriousness in the thought and life of the people, so that the preaching of the gospel has had free course. Religious thought has further been stimulated by the activities of the Buddhists in this center.

The Evangelistic Band The Evangelistic Band has proven itself, in at least two missions in this area, to be a very hopeful form of attack in the missionary campaign. The workers go together and mutually inspire each other. The hearers also realize that the Gospel Message is not connected with any peculiarity of one or two persons. Plans are being made to make the visit of bands through the country a fairly permanent feature, so that country places may not be restricted to simply an underpaid preacher of rather inferior talent. These bands also cause the leaders to get an intimate knowledge of the problems of the country, and they are able to carry their needs back to the centers.

Daily Vacation Bible School Through the activities of Dr. Boville, many of the students in this center, both girls and boys, have discovered the children of the poor and show great enthusiasm in carrying on daily schools for the children throughout the summer holiday. This activity links itself up with the general attempt to attain universal education and the more recent movement to do away with illiteracy. So far the students have been unable to carry on this work during term time because of the impossibility of finding rooms in which to hold the classes.

Prison Work For many years there have been those who carry out our Lord's injunction to visit those in prison, but it is only recently that the authorities have welcomed such visitors. Prison reform seems to have progressed so far in this center that all those in charge of the more important prisons welcome the assistance of the Christians in teaching and comforting those under their control. Many stirring tales are told, and one would judge that there are many more whose hearts can be touched in a Chinese prison than in a prison abroad.

Union Meetings The influence of the undertakings of any one portion of the Christian body in this center soon affects the rest because of the many gatherings of the Christians for prayer and conference. Each month all the different bodies gather in one place for a Chinese prayer meeting, and this is recognized as the regular place for reports and for the consideration of any plan for the action of the whole Christian body. The foreign ladies of Wuchang felt that much would be accomplished by a special foreign women's prayer meeting, and this has proved a source of information, inspiration and sympathy. For many years it has been difficult to arrange for a place and time for a union English service on Sunday, but during the past autumn, such a service has been arranged and carried out in the new chapel of St. Hilda's Girls' School. Although the chapel is outside the city, because of its proximity to two city gates, it has proven to be more central to the missionary body than any other place. Not a few government students have availed themselves of the privilege.

Girls' Blind School Directly out of the Women's Prayer Meeting grew the project for the Girls' Blind School. The women saw the great need for such an institution and began in full faith that means would be supplied. Captain Robert Dollar, the world known shipping magnate, supplied Wuchang with its Y.M.C.A. and he has also given liberally to the support of the Girls' Blind School. A permanent site has been purchased and a foreign woman has given her life to this service. She is assisted by the prayers, interest and assistance of many of the women of Wuchang.

Care of the Poor Famine relief work led many to ask whether we were caring for the poor at our doors, while the insistence of the beggars on the street corners led many to desire to give what relief might be possible. Investigation showed that some members of the Christian community were in greater need than any of the sturdy beggars, and also showed that it was possible to arouse the community to an interest to see that the very needy should be cared for. By making

preparations in advance and by careful planning, much help has been rendered. Special efforts are being expended in Hankow this fall among the rickshaw coolies, not only to give them physical relief but to treat them as fellow men.

Industrial Conferences Several conferences have been held during the past months, and the whole Christian body is being informed as to actual conditions, possibilities of improvement, and the dangers to be avoided in the new industrialism.

Girls' Union Normal School For years the primary education of the missions of this center has been unified in the Central China Christian Educational Association. With the development of interest in the education of girls and the need for diversification, it was generally agreed that it would be to the interests of all to have the normal training of girls carried on in one institution, and it was decided to ask the Wesleyan Girls' School to carry on this work with assistance from other missions.

Central China Teachers' College During the same period great developments have taken place in the Union Normal School, which has now taken the English name of Central China Teachers' College. In the school for the training of Primary Teachers no student is admitted without a seventh grade certificate or the proof of equivalent education. In the school for middle school teachers, students are expected to be graduates of the Association of the Central China Christian Educational middle schools. Several missions have joined the school and special agricultural training has been added.

Central China University The outstanding feature of educational development during this period has been the organization of the Central China University. The organization plans for a central teaching organization around which the collegiate units belonging to the various Christian bodies working throughout Central China will group themselves. Work will begin in September 1924, on the campus of Boone University, by the coöperation of

the American Church Mission, the Wesleyan Mission, and the Yale Mission. It is hoped that before the opening day, other units will have signified their adhesion to the scheme.

ALFRED A. GILMAN.

VII. MANCHURIA

The Presbyterian Church of Manchuria with which the Scottish and Irish Missions are connected, has for some years been decreasing in membership. At present the total number of baptised Christians is much the same as it was twenty-three years ago, just before the Boxer outbreak. This being the case, the Church's *inner* growth has been remarkable. For example, in the matter of liberality, within two years, the average annual contribution has increased about 50%, being now \$2 for each grown-up member. In other directions, progress is also notable.

Democracy To anyone hitherto familiar with the Synod of Manchuria, composed for the most part of grave and reverend Chinese seniors, a visit to the last meeting in July, 1923, would have brought a surprise. Crowded with members, having full voting powers, the hall included, for the first time, (a) women, and (b) young teachers, doctors and Y. M. C. A. secretaries. For, by order of the previous Synod, Kirk-sessions could send others besides pastors and elders to represent them. The missionaries formed a tiny minority. The revolution, bringing democratic rule into Presbyterian Church government, has been accomplished without even a groan.

The Power of the Purse Our advance towards an indigenous Chinese Church is further evidenced in two respects. (a) Three years ago the roll of pastors, called and supported by Chinese congregations, totalled 20; the roll has now 32. (b) Following the National Conference of 1922, a scheme of financial devolution had been drawn up, by which Mission appropriations for evangelistic, educational and medical purposes, with the exception of the Colleges in Moukden, were to be handed over to the Synod, which is the Supreme Court of the Church. The

Board of Finance was to consist of Chinese and foreigners, in equal numbers. Instead, however, of the Chinese leaders grasping at the control of the purse, thus freely offered, they are holding back. The reception of the offer was extremely cordial, and the harmony, characteristic of the relations between the Chinese presbyters and their foreign brethren, was in no way disturbed. But the leaders decided to proceed cautiously. At the 1923 meetings, the scheme, approved with a few slight modifications by the Home Boards, was postponed until District Finance Committees in local centers are more widely in operation.

Nevertheless, the die has been cast. The foreign Mission has abdicated its throne.

The Far North With its assigned sphere in the vast lands of the north, in the Province of Heilungkiang, our Chinese Missionary Society had been doing very well. We were, in fact, proud of it. And then one day the National Missionary Society gathered our fledgeling under her spacious wing, when lo! it suddenly clapped its wings and crowed. We rubbed our eyes at the apparition. What had actually happened? (a) Being invited to form auxiliaries, Church members rose with alacrity to the opportunity. (b) Money flowed in as never before. (c) An Executive was formed in 1922, with office in Harbin, independent of Synod, on a broadened basis, including the Danish Lutherans, who have gladly thrown all their weight into the movement. (d) New life has been put into the Society by the Executive's choice of the ideal man for the post of paid secretary, the Rev. K. Y. Shang. Among the best of the Manchurian ministers, Mr. Shang with his enthusiasm, learning, tact and humour, is everywhere respected and beloved. Thanks then to the wise heads of the N. M. S., our Missionary Society has now shot up into vigorous manhood. It has five pastors in the north, one of them a graduate from the 1923 class of the Theological School of Yenching University. A graduate of Moukden Girls' Normal School went up to Heilungkiang in 1923 to act as Biblewoman.

**Education
Board**

Formerly, owing to labours of the pioneers, the Provinces east of the Barrier were noted for evangelism. We were slow to put money and strength into educational institutions, and when we did begin, it was at the top,—hardly a strong type of architecture, albeit inevitable in the circumstances. While the Manchuria Christian College has done excellently, we have wakened up to the necessity of digging down to the foundations. For our primary and middle schools, aside from some exemplary districts, have left much to be desired. Accordingly, an Education Board for both Lutherans and Presbyterians, has come into being. With competent educational experts, Chinese and foreign,—deliberations being in the vernacular,—taking over the control of finance, the Board is making a valiant fight to lift the more backward Church schools to a higher level.

After heavily taxing his powers at the Summer Training School for Teachers in Moukden, 1923, Mr. Y. K. Sun, the Chinese secretary of the Board, was struck down and died of typhoid fever. He had been exactly the right man for the position. The foreign secretary, the Rev. J. W. Findlay, is not yet free to devote his whole time to the advancement of education.

**Spiritual
Awakening**

The most important indication of progress remains to be recorded. Without any very noticeable outward signs of revival, nothing indeed to compare with the emotional upheaval of 1908, a real spiritual awakening has been taking place. This is seen in a variety of ways. (a) Instead of contenting themselves with being spoon-fed, our Christians are much more ready than formerly to shoulder responsibility. (b) In regard to social evils, a new conscience has appeared. Supplementing the old emphasis on the salvation of the individual soul, the Social Gospel is being preached from our Chinese pulpits. For the last two years, the Synod has occupied a large portion of its time in tackling questions bearing on the Church's relation to the world we live in, with a view to practical action in social service. (c) There is a shifting of aim in religious teaching. The child is now to the front. And the Church is to a less extent our sole care, for the cry is, "Make the Home

Christian." (d) Young men are more willing to take up the Cross. The Student Volunteer Movement has recently had encouraging success. It is hoped that several of the Manchuria Christian College graduates of 1923 will go on to study for the ministry. (e) Finally, this awakening has the mark of permanence, because it is due to a deepened sense of sincerity, a closer touch with the mind and heart of our Lord Jesus Christ.

F. W. S. O'NEILL.

CHAPTER XV

THE RURAL CHURCH AND ITS RELATION TO RELIGIOUS, EDUCATIONAL, MEDICAL AND SOCIAL WORK.

K. T. Chung.

Dr. K. L. Butterfield of the Massachusetts Agricultural College reported that there are 300,000,000 farmers, 10,000 market places and 1,000,000 hamlets in China. Eighty-five per cent of the Chinese people are in the rural districts. The problem of China is not therefore the problem of Peking or any other large city. China must be reconstructed from her base; that base is the rural district. If the farmers remain at the mercy of the gentry and of the country officials, if they continue to lack the education which will fit them for proper citizenship, the modern ideas they need in agriculture, and the Gospel which can redeem their social life, then China need not expect that her future will bring any improvement over the present.

**Position of
Farmers** It is encouraging to realize the stability of the Chinese race, due largely to the power of resistance in the country people. They are the ones who really stand firm against existing chaotic and far from ideal conditions; they are doing their best to serve the country and by their diligent labor feed and clothe China, and produce a surplus for export to world markets. Yet no one feels any responsibility about their welfare and only those who wish to live on them are willing to live with them.

The farmers are the real China. Anything done for their betterment conserves the life of China, develops the spirit of the Chinese race and contributes to the world's civilization. All those who work among these simple and devoted folk, find their hearts throbbing with joy because of the great opportunities for service. They are like sheep without a shepherd. Those who get a chance for education become their natural leaders.

The opportunity for work in the rural churches is tremendous. We often find these people coming to Christians to seek for justice and refuge from tyranny. The fellowship of the country Christians is a dominant factor in Christianizing the community. They are a latent force in promoting better farming, better business and better living. It is up to the Church to train them for and lead them in a Christian program of village development.

Rural Church The small family system is gradually taking the place of the old patriarchal one. The Church will be the center of life, the "new ancestral hall" of family and clan life. There they worship God as their common Father and regard their fellow villagers as their brothers and sisters. They form a "big family" of Christian members which looks after the physical, intellectual, social and spiritual needs of its members. Perhaps it is in these rural districts that we shall see the real indigenous church arise.

Our Lord Jesus Christ lived in Nazareth a village of Galilee for thirty years. His message is, therefore peculiarly acceptable to the Chinese farmer. The power of His life will be full of meaning for what is so often looked upon as the "weaker class". Christ's Word is life. If it is sown it will grow naturally until the harvest. A little band of faithful ones in this village or that hamlet who bind themselves together by prayer and reading of the Word and adventurous service will grow stronger and bigger every day until they become the church of the farmers, run by the farmers and for the farmers.

In reviewing the present situation of the Christian movement in China the work is more or less centralized in the "so called" strategic centers. Any country work done is generally undertaken by persons not needed in the cities. The time has come when we should look beyond the city walls, and go right out into the country places where the beauty of nature and the glory of God's work is manifested clearly before us. Rural work needs the organized efforts of missions and workers, local congregations, men and women, students and members of churches, Chinese and foreign. We need to find out what our part is as workers,

either evangelistic, educational, medical or social, in forwarding the work of this immense field of which the churches at present are only touching the fringe.

In facing this work the following points might be considered:

Redistribution of Forces (1) *Perhaps it is time for those who engage in the direct work of evangelism to reconsider the distribution of forces and of money for the work.*

There are many villagers in these hamlets who never come to the market places. How can they hear the Gospel if we preach in the cities only? God's children are scattered in the smaller places, as well as in the bigger ones. They are waiting in beautiful groves to be called into His fold. There will also come many dominant leaders from the wilderness to be prophets to the present generation. This situation demands the readjustment of the entire plan of our church work. We should give Christian workers as well as laymen ample opportunity to engage in this phase of service. Work should be started on Sundays or week-ends by open-air preaching, or the worship of two or three to whom Christ promised His living presence. This will mean the growth of Chinese Christians in faith and love.

Rural Education (2) *The tendency of the Christian schools and colleges in China is to take boys and girls from the country, bring them up in the city, and never send them back.* This is a tremendous loss to country districts, for it means that they have to wait still another generation for their leaders. Changes in curricula, in buildings, in centers where schools are established, in teaching staff, and in the selection of candidates for school positions are necessary. During summer and winter vacations students can spend their time in the villages. Rural surveys should be arranged. Short-term schools should be opened. In these, students might teach. To sympathize with and help their fellow citizens is a real expression of love of country on the part of students.

Rural Hospitals (3) *Medical work.* Most of the hospitals are in big cities. Only rich farmers can come to the cities for treatment. Medical missions have developed into strong individual organizations. It is not as in former times, when preaching and healing were done

by the one man who visited every place which was open to him, whether town, market place or village. Popular education on sanitation should be given during festival times.

**Rural
Betterment** (4) *Social work.* In the country places there are sufficient forces for local social betterment, if they once get the idea of the power of fellowship among themselves and realize their responsibility to the community. They will build good roads, dredge the canals, reforest the land, build village playgrounds, and organize coöperative selling and buying. They are a willing army, but lack able leaders. If every village had its own program for Christian development, the reconstruction of China right from the foundation would begin. It may be that the institutional church movement should also be directed to the rural districts as well. The experience of the Y. M. C. A. and Y. W. C. A. movement in China would be an invaluable help to these, the rural units of the Republic. Individuals, students, congregations, Church Federations, and missions should unify their efforts for this common task.

With the combined effort of the standing committee of the National Christian Council on Rural Problems and the Country Church, the standing committee of the China Christian Educational Association on Agricultural Education, with the coöperation of the colleges of Forestry and Agriculture and some thirty agricultural missionaries, the Church of China should be able to tackle this rural church problem in a comprehensive and organized way.

CHAPTER XVI

THE CHINESE CHURCH AND CHANGING CHINA

T. C. Chao

Changes The year 1923 saw many changes in China. The most prominent changes were the rapid development of banditry; the departure of Li Yuan-hung from Peking; the entrance of Tsao Kun into the office of President of the Republic of China, both by foul and passive means, petty wars that rose and fell; the anti-Japanese movement and the boycott of Japanese goods; depression in educational institutions, and the deterioration of the spirit of the students in most schools. It was, therefore, a desperate year. Instead of a reduction of armies, there was an increase. Bad government went hand in hand with unsatisfactory educational conditions and poor business. On the side of the intellect and spirit of the nation, it is evident that while old moral restraints were being thrown to the four winds, the young fed themselves on such things as free love, rebellion against family and school authorities, personal happiness, and pleasure. Apparently social, moral, and religious life, went on under severe criticism, and without any semblance of sanction. The son thought himself wiser than the father, the student acted more authoritatively than the teacher, the ignorant spoke louder than the learned, and the worthless seemed more honorable than the good. It was a desperate year when looked at from the viewpoint of evils that existed and still exist.

Hopeful Signs But since the gates of the temple of Janus are wide open we ought to look at both faces. It is trite to speak of such a time as transitional, and in that find excuse for certain evils. Yet the optimistic spirit, though oppressed by this exhibition of evils, has good reason to reassert itself, and that without equivocation. We cannot be blind to certain signs of life in the nation,

in spite of the fact that there are among us so many calamity howlers, both native and foreign, and that certain foreign friends have changed their attitude toward China and the Chinese people after untoward experiences at the hands of the bandits, or in traveling. The Association for the Advancement of Education did some very significant work as seen, for instance, in the sixteen bulletins it issued. The popular education movement was more than a fad. The friendly spirit shown by the Chinese people to the Japanese after the earthquake, when those most energetic in boycotting Japanese goods took the lead in raising funds for the relief of Japanese sufferers, was not a display of hypocrisy. The people were much more alert in political matters than before. Public opinion is in many respects still at fault, yet it is rapidly growing more intelligent. Democratic ideas, communicated with much difficulty on account of the lack of adequate means, have, nevertheless, been successfully fixed in the minds of many. The spirit of social service is rising everywhere. An incredible number of people are beginning to take an interest in athletics and health movements. The women of China are quietly taking their place in society and asserting their rights in the family. Altruism is broadcast in magazines and conversation. In the rising national consciousness, the prophet can plainly see the growing oneness of the nation, in spite of the political divisions for which tuchuns and generals, who do not represent the people, are responsible. He who cannot see progress in the Chinese people to-day is blind indeed.

**Church Faces
Situation** Amidst such changes, when evil darkens the face of the day, the church, criticized though she is, has not only become conscious of her imperfection and her task, but is also taking vigorous measures to meet the situation. While it is undeniable that the various denominations as such are not wide-awake, and while the local churches in many cases fail to see the demands of the day and, therefore, do not rise to the opportunities before them, the church, as an indivisible fellowship and as a group of Christian organizations, is looking at the situation with wide-open eyes and

ready hands. The students are demanding an explanation of the "faith". The Young Men's Christian Association, in its ninth National Convention, perfected a Christian student organization. This was one attempt to answer the students and to meet student needs. A group of Christian literary men also tried to meet this situation with more adequate interpretations of the Christian life. The opium question, industrial and moral problems, the need for energetic evangelistic work, the family question, and international issues have become insistent in their demand for the church's attention and service. The church, through the National Christian Council, created a number of working groups composed of people who are more or less expert in their lines to deal with these things. Much therefore has been done. Unsatisfactory as is the literature produced by the Church, the books published during the last year are far better than those of preceding years. Those who love their own denominations are beginning to realize that their loyalty to Christ is of primary importance. This is making Christian coöperation easier. Many Chinese Christians are forgetting *consciously* their denominational differences.

Education Through Christian education also, the church is making rapid progress. In spite of difficulties in raising funds for educational expansion and in spite of unfavorable criticisms directed at them by disgruntled and ignorant Chinese, Christian educational institutions have shown an amount of correlation and coöperation that may be said to be unprecedented in the history of missions in China. The East China Christian Educational Association, for instance, is putting up a vigorous program and conducting a keen investigation of the middle school and normal school situation. There has also been coöperation between Christian and Government schools. The employment by the National Association for the Advancement of Education of Prof. Terman of Yen-ching University to make an educational survey of schools throughout the nation is prophetic of a new relationship between these two groups of schools and of a great future for Christian education.

Strong Points in Church While some folks are fighting over words, doctrines, phrases, and interpretations, the wise and devout are exerting themselves in loving service and good deeds. The most valuable things in the Church in China to-day are (1) its unreserved efforts at spreading the Gospel in the land; (2) the growing consciousness of the need of meeting the demands and the heart of the Chinese people by the creation of an indigenous church and the small beginnings shown in attempts at the working out of certain indigenous forms, (3) the emphasis on Chinese leadership and responsibility, and (4) the growing social spirit. These seeds must grow, and both missionaries and Chinese Christians are uniting in watering the tender plants. There is also an awakening in the Church to the necessity of giving an adequate Christian philosophy of life to the people now groping in the dark, and also of giving them practical assistance in the working out of the new problems that are now vexing the minds of the thoughtful in regard to family relations, birth, death, marriage, making a livelihood and service. The church has begun to understand the vastness of its task, to enter upon some small experiments. All this is very hopeful.

Needs But in the face of such a situation, wherein changes are often unanticipated and stupendous, the Church is still unable by reason of inadequate strength and equipment, to cope with the many problems demanding solution. In the first place she needs a strong native leadership which does not make its appearance fast enough. She is in urgent need of an adequate and educated ministry, for the clergy, at present, not merely too small in numbers, but also too untrained to carry on the work.

Dissatisfaction Preachers in large cities cannot satisfy the spiritual hunger of the people whom they serve, and pastors in the smaller towns do not know how to cultivate a stable and permanent Christian constituency. Never has there been such dissatisfaction as now exists both within and without the Church with those who perform the duty of feeding the believers with intellectual

and spiritual food. There is also needed an army of social workers, literary men and women, and lay-leaders in various lines of church work. On account of this lack of a spiritual and aggressive leadership, the Church is not as enterprising as she should or might be.

**More
Mobilization
Needed** Again, we find that the Church is not fully conscious of the need of cooperating with all existing social agencies in the task of social regeneration and national reconstruction.

She has not exerted herself as she might have done to mobilize the forces at her command. Entirely too insignificant a number of church members take active part in the Church's attempts to serve the Christian constituency and the non-Christian community. In too many cases the church exists on Sunday alone and only for those who go to Sunday services. Old Testament ethics are preached in contrast to the lack of ethics in the people's everyday life. The avowal that the Church creates new and powerful men and women for the nation is not carried out, and eagerness to make high-sounding reports is far greater than anxiety to win souls to the Kingdom of God. The real humiliation of the Church to-day is in her empty pride and her unwarranted sense of superiority in the religious and moral life — a claim which in all too many cases is not borne out by facts. Can the Church stand the moral scrutiny of this inquisitive day?

**Religious
Education** This leads me to ask, whether the Church is doing her best to formulate an aggressive program for religious education which will give room for the development of various types of service and life, but which will not force people upon any Procrustean bed to suit ancient and/or traditional schemes. Any system of instruction that does not provide an outlet for energy in the ethical life of the day, in the solution of everyday problems, and in the betterment of the character and living conditions of those who come under such instruction, is not worth the giving and is a positive waste of energy, money and effort. We must be fair. On the one hand we realize the difficulties that beset efficient religious education. But we see on the other hand that

the insignificant number of activities and people that carry on such activities, casts a dark shadow in the bright light of the day.

**United Front
Needed**

Finally, we see local churches taking most interest in merely local church problems; the Church at large has not awakened to the most urgent present need, that of presenting a united front and bearing a common witness to the non-Christian world. It is surprising to find so much devotion to denominations, even among the Chinese Christians, without a corresponding loyalty to the great and invisible fellowship of all denominations. But no justice can be done to the spiritual life and thought of the Church as a whole, if no attempt is made to create a church, every part and member of which reads. Until the Church has become an intelligent judge in spiritual things, she is incompetent to make any decision on the matters that threaten to rend Christian people into meaningless parties at a time when united effort is most needed. The Church up to the end of 1923 did not have a sufficient measure of tolerance and open-mindedness. The Church after 1923 should find it possible for her adherents to be loyal to the regiments to which they severally belong, and at the same time to be at one with the rest of the great Church of God. All are citizens of the one Kingdom. The slogan is: "Seek first His Kingdom."

A small number of believers in the Church has come to realize that many readjustments are needed to meet these changing conditions. Unless these readjustments are made she will not fulfill her vast task or be firmly rooted and grounded in Chinese life.

CHAPTER XVII

THE STATUS OF SELF-SUPPORT

Robert E. Chandler

These notes are taken from reports, or observations, of Mission work in nine different provinces and Manchuria. For the most part, they refer to conditions in country churches. City churches, we would expect, can earlier attain financial independence. The Chinese Church must be established in the country, however, and the largest problems need to be settled in the country villages. Returns are by no means exhaustive. Comments were requested from missionaries of districts where some success in this matter was believed to have been obtained. It is interesting to observe that the missionaries on the ground sometimes have an estimate different from the general report about their work. They may feel that the status of self-support is far less satisfactory than the reputation of their work shows: The reverse is sometimes true.

What Is Self-Support? The difficulties of comparison and of estimate appear immediately in the variety of definitions of "Self-support." At least three different definitions, or grades of definition, may be distinguished:

1. A self-supporting church is one which meets the total expense of its Christian work including the salary of its pastor or preacher, all expenses for maintenance, such as fuel and repairs and the expenses of schools or other enterprises managed by or connected with it.

Such a church usually contributes, to a large extent, also, to general funds outside its own work, in its diocese or association, or for home missionary work.

2. "A self-supporting church is a company of believers, organized as a church, with some kind of administrative officers, and supporting, by its contributions, a pastor who administers ordinances, and statedly preaches the Gospel to the people."

This is the definition used by Dr. C. W. Mateer in discussion of Dr. Nevius' "Methods of Mission Work." This is the commonest usage for the term. Such a church may be receiving a Mission subsidy for a school, or for women's work, or both; and also share in the privileges of a central administration.

3. Self-supporting churches are those which pay all their own material expenses, and provide for all regular spiritual ministrations, although these do not imply the employment of a salaried pastor or evangelist.

The differences of definition show something of the diverse views among missionaries, and diverse conditions among the Chinese Churches. There are also considerable differences due to the varying degree of connectionalism. Some groups are not trying to work for the self-support of single congregations, but rather to raise the self-support of the whole Church in the diocese or association. All churches contribute to a common fund, and the superfluity of one makes up for the deficiency of another.

Progress Considerable "success" is reported among churches in country districts, from Changsha, Hunan, from the English Baptist field in Shantung, from Kwangtung Province, from Fukien, north and south, from Manchuria, and from Honan. These are all on the basis of definition (2), though in many, perhaps most cases, it is not a single country church which supports a pastor, but a group of from five to twenty which unites in such calling and support. The Liebenzeller Mission in Hunan shows a rather remarkable change in a short time, due to a stoppage of all funds from the Home Society for the support of churches. In April, 1920, no churches were self-supporting, not even in part. Within about two years and a half, there were sixty-one evangelistic workers associated with the Mission. Of these twenty were supported fully, and fifteen in part, by the Chinese. Chapels were being built, also, with funds locally raised. A number of other districts report a great deal of difficulty in passing from the old idea of receiving everything from the Mission, including pastors and other workers and buildings and

sundry expenses, to the new plan of self-support at the very earliest date. "Every dollar given in the earlier days of the mission seems to have made it more difficult, later, to get the Christians to consider seriously the question of giving as part of their duty and privilege." If self-support be on the highest pecuniary standard, as per definition (1) above, there are some very striking examples. But these are in the largest cities. Some such are connected with the Sheng Kung Hui; others are independent undenominational Chinese Churches. The third sort of self-support, according with definition (3) above, would agree with Dr. Nevius' principles. And the most thorough-going application of these, in the London Mission work in Chihli Province deserve some separate discussion.

Philanthropy From all quarters it is reported that the practice of giving to larger causes arose early in the life of the Church, and not merely to its own local needs. A broad vision of the Christian cause (in China and elsewhere in the world), and a feeling of comradeship and close association, are thus cultivated. There is great diversity, however, as to the order of causes to which a newly growing church will give its efforts. Many churches will start and carry forward a school, and perhaps medical work as well, before they pay anything towards the support of their local pastor. In such cases, it is usually true that the pastor serves the broad countryside, and not the local church alone. In some cases the gifts of the church members to local enterprises, and to general causes such as home missions, are reported to be equal in total to the salary of the pastor. Still they cannot be ranked as self-supporting.

Salaries As to connectionalism, in the binding up of the individual local church with a larger group, there is far less difference among the missions and denominations than might be expected. All are apparently being led to feel and to cherish the strength of the group. Pastors are called by districts or groups. Salaries, in general, are fixed by central organizations. These fix yearly grants made to churches from mission funds, or from other funds. It does not appear that there is an over-development of "congregationalism" in church policy.

This in spite of the comment of a Bishop in the Sheng Kung Hui, that the principle of self-support in his diocese is "too congregational and parochial!" In many cases the difficulty of raising salaries, year by year, to meet living conditions is spoken of. And it would appear that the central boards or committees become somewhat remote from the lay membership. The system of gradual reduction of grants is commonly practised, but does not give full satisfaction. "It seems to me a little worse than useless to attempt to force our churches into independence by slowly turning off the tap. Better spiritual health in our churches will lead to a natural movement for independence." The danger and the futility of over-developed machinery of ecclesiasticism show markedly at this point. It must be the laymen and women who shall settle whether there shall be a self-supporting indigenous Chinese Church or not, and of what sort. If they are not in close connection with the problems, if they do not feel that the whole enterprise is their own, there is not much use in policies and resolutions passed by "office-holders of the church." This connection of the laymen with the church enterprise is much closer, usually, in the city churches. They show no hesitation or difficulty in raising salaries, when needed, and in keeping the support adequate for every enterprise that they undertake.

Is Paid
Ministry
Essential?

Is a professional paid ministry for the Chinese Church necessary and permanent? The question leads us to the heart of the discussion. The question was by no means settled in Dr. Nevius' time, twenty-five years ago. It will not be settled until the Chinese Church can speak. In the meantime, missionaries and Chinese leaders must follow the light they have. The replies received on this question, as put, were most significant. Four reports from different parts of the country, in Anglican, Baptist, and two kinds of Presbyterian churches, accepted the paid ministry, without question, as permanent, and necessary, and right. Five other reports from those same church groups and others, spoke of the paid ministry as "apparently fixed;" but they have a feeling of uneasiness. They are not sure that it is the right thing, especially for the village church in China. Ar

Anglican Bishop spoke strongly: "The paid ministry is one of those crimes, like denominationalism, which Western Christianity has perpetrated in the East!" One reply holds the view that paid ministers in the country churches "are an expensive, unnecessary luxury." They may be more of a hindrance than a help. It is admitted that such ministers may be necessary for the churches in the larger cities. The mission in this district (the L.M.S. field in Ts'angchow and Siaochang, Chihli) have set themselves against the whole policy of local paid preachers. They maintain "a mobile preaching force" of evangelists, whose task is to evangelize the district as a whole, aiming particularly at the places as yet unreached. They endeavor, at the same time, to keep in living touch with the little groups of Christians or new churches, and to develop the latent leadership within them. The churches founded "are expected to be self-supporting from the start; on the material side, they shall provide their own buildings and equipment, and meet their own current expenses; on the spiritual side they shall learn to depend also, through prayer and study of the Bible, on God, rather than on man, and through fellowship, to depend on one another, rather than outside helpers. And further, they shall feel it their highest duty and privilege to pass on the Gospel they have received to those round about them." A survey was made in 1913, in company with Mr. Sidney J. W. Clark. The magnitude of the task, and the inadequacy of the spoon-feeding methods then used, were simultaneously seen. A complete change of policy was inaugurated — with great difficulty, in the older churches. The spiritual vitality of the younger churches seems fully to justify the change. It appears that principles that many other missionaries favor are being whole-heartedly carried out here. Progress thus far has been good despite the difficulty of the war years and the poverty of the Mission.

Cost of Living The most various answers have come to the question: "Does the rise in the cost of living make self-support more difficult?" Of course missionaries in the voluntary worker district, just described, will say that self-support is not more difficult. Chinese leaders in the cities, also, seem to be unconcerned about this matter,

The "earning power of the ordinary Chinese Christians is increasing fully as fast" as the price of necessities. The number of replies saying strongly, "No," or "Yes," was equal. There were other replies in between these two.

We cannot say that Chinese churches are reaching the summit of their ability in self-support. As to the right principles and methods of progress, the Chinese Church must speak for itself. Probably it is unable to speak with clearness and finality at present. May God give new wisdom to churches and missions in the use or non-use of money.

CHAPTER XVIII

THE COMMUNITY CHURCH IN CHINA

R. T. Henry

History Community Church work has a long and interesting history. In England plans were made as early as 1840 to bring the church into closer relation with the secular world. The fuller development of the Institutional Church, however, belongs to the latter part of the nineteenth century. In the United States the movement may be said to date from about 1880. The name "Institutional" was first applied to Berkley Temple, Boston, by Dr. William Jewett Tucker, then President of Dartmouth College. In 1894 the Open Institutional Church League at New York was formed. This held a number of conventions and served as headquarters for the numerous separate churches. In connection with this League was later formed the "National Federation of Churches and Christian Workers."

The work in China is the product of the last ten years. Of the seventy churches now in existence only ten have been organized more than six years. This indicates that the China movement is still in its infancy. Even though more or less recent the movement is meeting a long recognized need and under proper direction can and will reach classes thus far unchurched. The movement has become nation-wide in its scope and at present thirteen provinces have some work of this kind. Shanghai has the largest number of centers engaged in this work, there being about nine.

During the National Christian Conference, Shanghai, 1922, plans were launched to form an organization which would bring together those interested in this particular type of work. A special Committee was appointed by the Conference to study the needs and to take steps towards

drafting a constitution and securing membership. At present there are eleven denominations represented in this organization with a total membership of 102.

Organization in China In May 1923 a Conference of those commonly designated "Institutional Church Workers" was called and met in Shanghai at the Cantonese Baptist Church. This Conference gave vision and horizon to institutional church workers. Commissions had been previously appointed to study the following questions and bring in findings to the Conference: The Training of the Volunteer and Paid Worker, Finance and Equipment, Administration and Organization, Survey and Program. This work would not have been accomplished but for the untiring efforts of Rev. A. R. Kepler, of the Nantao Institute, Shanghai. He has been elected Traveling Secretary for the movement.

What Is a Community Church? As indicated above the term generally used in America and England has been "Institutional." But in recent years this term has come under severe criticism. It is charged that this term makes the Church a secular institution, or tends in the direction of making it a machine, rather than a living power in the community. In China the tendency has been in the direction of using the term "Community." to designate those churches which supplement the ordinary forms of church activity by others. In America on the contrary the term "Community Church" has generally meant those churches of various denominations which have combined into one church.

It has been said that the Community Church adds to the commonly designated ecclesiastical activities, those which meet the whole need of men, such as reading rooms, games and the like. The China Conference of Community Church Workers decided on the following definition — "A Community Church is a church which is making definite efforts to apply the principles of Christ to all the individual and social life of the community." This definition does not limit the Community Church in equipment or budget, and makes it possible to unite a number of churches carrying on some or all of those activities included in the whole program.

Purpose

In the above definition we find the real purpose and intent of the Community Church—namely an agency to Christianize and conserve the whole life of man. It uses equipment to reach men and through this touch with their interests seeks to lead them into a deeper realization of their relationship to God and man. Big staffs and big budgets are not essential to successful community church work. Given a leader, with a “Bible and a ball, one can open a Community Church with Departments of, (1) Worship, (2) Religious Education, (3) Evening School, (4) Reading Room, (5) Physical Recreation.”

Following close upon the purpose of the Community Church to deal with the whole man, is the fact that it develops social consciousness. When we are face to face with the problem of conservative custom, it is most difficult to secure for new ideas a fair hearing. It must be remembered that it is one aim of the Community Church to develop sympathy and understanding, in order to get men to see the needs of society about them.

The need for an awakened social consciousness is also recognized in the desire to arouse a feeling of responsibility for civic morals and the administration of law and order. The time has passed when the Church can draw aside and say that it will have nothing to do with the problem of government. China to day needs above all else the contribution of the Christian Church.

Recognizing that the task of awakening social consciousness belongs to the Community Church as well as to other organizations, an added responsibility comes in the necessity of giving direction to this awakened consciousness. It is not to be expected that the Community Church can do all that ought to be done in any community. It has neither the man power nor the money for that. But it can maintain a place of leadership.

Furthermore the Community Church provides opportunity for the individual to render service. The mature Christian can find opportunity for working along side his non-Christian friend and through this comradeship in task find the road to Christ.

Difficulties What are some of the difficulties in the way of the development of the Community Church in China?

One of the biggest difficulties is the securing and maintaining of a thoroughly Christian membership. With the establishment of the Community Church comes added opportunity for demonstrating the value of the Christian life. Therefore the member of such a church has a larger responsibility as to the kind of testimony his life bears.

Thus far we have not mentioned the leader. But if any Community Church would really touch the life of its people, it must depend upon a leader of untiring devotion. In the ordinary church the worker has been more or less free as to the direction of his time. This has placed both missionary and Chinese worker in a position that makes it easy to form haphazard habits. This does not mean to say that all have formed such habits. This new work demands much time, energy, and thought. It is not a task for occasional or spasmodic effort.

The Church as such must never be overshadowed by the more popular activities of a social nature. These activities must ever be kept as arms to reach out and bring men into the Church. For the business of any church, be it community or otherwise, extension of the Kingdom.

PART IV
COÖPERATIVE MOVEMENTS IN CHINA

CHAPTER XIX

THE FORWARD PROGRAM OF THE NATIONAL
CHRISTIAN COUNCIL

Henry T. Hodgkin

The National Christian Council has been called into existence in order to serve the Christian forces in China and is not, therefore, a body which should be looked to for the inauguration of its own policies. It does not enter upon its task with the idea of creating a program, as it were, out of nothing; and any program which comes from the N.C.C. should be one which reflects the desires and hopes of the various Christian forces in China. Its fulfillment will thus be regarded by them as a part of the task in which they are themselves engaged. To summarize in detail the objects of the N.C.C. we may give four: *First* to discover what the churches and missions seem to need; *second*, to make suggestions in regard to these specific needs *third*, to help the churches in discovering other ways by which their work may be improved and of which they may not at present be distinctly conscious; and *fourth*, to correlate the varied activities of the different churches so that in every possible way the work of the whole Christian movement may be seen to be a unity in spirit and aim if not in organization. The fourth purpose here mentioned may, so far as this paper is concerned, be omitted. Certain outstanding needs felt by the churches and missions have engaged the Council's attention and may here be stated:

Needs Already Felt I. It soon became evident to the officers of the Council that no need was more keenly felt throughout the churches in China than that for a *deeper spiritual experience*, or, as some one has put it, "an increase of the spiritual efficiency of all our work".

From every part of the country the question came, "What can you do to help?" The answer of the N. C. C. has been mainly to direct attention to the great value of the small group conference or retreat, where a few chosen leaders, Chinese and foreign, can meet together for a long enough time to discuss unhurriedly the work that is committed to them, and to seek for Divine guidance and the renewal of their own spiritual life. In a number of cases the Council has arranged for the holding of retreats. One of the secretaries or some other suitable person has visited the locality in order either to lead the retreat or make some special contribution to it. The great hope of the Council is that this plan may be adopted more and more throughout the entire field, quite apart from any arrangement made by the Council itself. To this end a letter has been addressed to all Christian workers in China and suggestions, both for the holding of retreats in general and for the discussion of particular topics, have been prepared. The Council looks to this method not only for the deepening of the spiritual life of those who meet in such gatherings, but also as the starting point of a new evangelistic fervor throughout the churches. The Council is, in some cases, planning for the carrying on of definite evangelistic efforts with the help of visitors. The emphasis which it would place upon evangelism, however, would be even more upon the call to every church member, in his own way and according to his own opportunities to be a soul winner. Evangelism being the prime duty of the church should not be entrusted to a special group of evangelists *only*.

II. The second need felt in many parts of the field is being cared for particularly by the Committee on the COUNTRY CHURCH AND RURAL PROBLEMS. It has been the habit for years past to think of missionary work largely in terms of the great cities which have been spoken of as "strategic centers". Opinion seems to be moving rather in the direction of recognizing the very great importance of the country, not only in the economic sphere, but also in providing men and women of the type needed for national leadership. The tendency of central organization is always to think in terms of the town and big city and

to over emphasise their relative importance. The missionary movement has not escaped this danger. The program of the N. C. C. includes a very earnest effort to correct the mistake. No one who thinks about missionary problems fails to realize the importance of developing the Christian Church in every land as a truly indigenous organization; but few seem to realize how closely this is bound up with the development of the rural church as a genuine community center having its roots in the common life of the people and meeting their every-day needs. The N. C. C. stands for Chinese leadership and for the contribution of China, and especially of the Church in China, to the development of the common life of humanity. In connection with the Committee on International Relations a careful study is being instituted and a number of the leading educational institutions are taking part in it. Its object is to bring together the best thought of Christian China on some of the great questions which are being faced in the world to-day, in order both to clarify the thinking of Chinese Christians and to make clear to others what China has to bring to the world.

III The third main line of activity is in regard to APPLIED CHRISTIANITY. In the industrial centers where the ideals and methods of east and west are meeting and re-acting upon one another, there is a strong conviction among Christian leaders that the church should help in this perplexing and dangerous situation. Great evils have come into China partly through the contact of China with foreign nations, and in some cases the difficulty of handling these evils is increased because of the international relations. A few years ago China was able in a remarkable way to handle the opium situation, and the rest of the world looked on amazed at the result achieved so rapidly; to-day, owing largely to the political unsettlement and the financial chaos, China is rapidly slipping back into a condition even worse than that from which she escaped, worse especially because of the addition of other forms of the drug habit more deadly in their result than the smoking of opium. The N. C. C. seeks to bring together the forces which should coöperate in meeting this evil, greatly hoping that the Church may through such coöperation become a far more

effective force in dealing with this evil than it has been in the past. The dangers to the home life and some of the most significant social institutions of China through this mixing of different cultural streams is engaging the earnest attention of the Council. Within a short time something should be done to put before the country the Christian conception of home life as the only way out of the present confusion. One of the most important factors in these large centers tending to disturb the old conditions and create new evils is modern, large scale industry, and one of the most vigorous sections of the Council's work is that which is directed to a thorough investigation of present conditions and the making of a fearless witness in relation to them.

In each of these three main directions there is no doubt that the Council is dealing with needs widely felt among Christians. It is also true that a divided Church cannot face these problems nearly so effectively as one which has an organ through which unity of thought and practice may be reached and by means of which each different group may make its contribution to the life of the whole.

**Looking into
the Future**

It is much more difficult to indicate the direction in which the Council is beginning to discover needs of which the churches have not been actually conscious but which some here and there have felt strongly. These needs are being revealed through retreats and similar small groups, through prayerful consideration of our work and through personal contact with leaders in different parts. A chief means is the travel of the secretaries and the many opportunities which come to them of quiet discussion with people who in the ordinary way of things are so busy as hardly to be able themselves to think back to the deeper causes of the difficulties they are facing. Some of the problems which may be included under this general heading are the following:

(1) *The need of more indigenous Christian literature.* While a great deal of splendid literature is available through the work of many persons and societies, there seems still to be a very distinct need for Christian literature springing out of the religious experience of Chinese and their own attempts to express themselves. What might

not be the result of a Chinese author bringing with vivid and picturesque detail this wondrous story to the minds and hearts of the rising generation in this land? What mines of rich material have as yet scarcely been tapped in the opening up of the great ideas of the Chinese classics and their interpretation in the light of the teaching of Jesus, so that they are made to live for this generation not simply as ancient and beautiful truths but as dynamic principles for the making of a new China.

(2) *The need of improvement in religious education.* The recent Commission summing up the situation says, "Progress in this field lags behind that in almost every other department of education. Mission schools fail oftener here than in mathematics or science." While this need has been strikingly brought home to those who have studied the Report, very many are only just beginning to realize how serious this lack is. It refers not only to the schools and the school curriculum, but to the home education of children, to the religious education of adults and to special courses in summer schools, etc. The N. C. C. in close coöperation with the Educational Association, the Sunday School Union and other organizations, is seeking to handle this most urgent situation.

(3) *The need for fresh thinking on the conservation of results.* In a few cases where active Christian work is being carried on, it must be admitted that the results are not conserved, for though more men and women are constantly being added to the church, the net result does not seem to be proportionate to the combined efforts, and this is largely due to the fact that those who join the church, after a few years, in many cases drift away from it. This serious leakage must be stopped, but very few people are really giving attention to the question.

(4) *The need for a unification of thought and policy in relation to public affairs.* This has been brought home especially to missionary administrators by the very unsettled state of many parts of the country. The executive committee has already issued a call to the missions and churches dealing with one aspect of the problem (see N. C. C. Bulletin for October 1923). But there are many other aspects to be considered and in determining

upon right action, Chinese and missionary leaders should confer together and understand one another even if the matters are of such a character as to require handling separately by the Chinese churches and by the foreign missions. The N. C. C. provides an ideal meeting-place for the frank discussion of this intricate question, involving such problems as the relation of Church and State, the use of force in restraint, extraterritorial rights, etc.

(5) *The need for a reconsideration of our method of presenting the Gospel.* We have but the one Gospel, and its power is the same to-day as when Paul determined long ago to know nothing but Christ and Him crucified. How to bring this saving word effectively to an age and race whose thought forms and specific approach to life are in many ways different from that of the first century in Europe, is an ever-recurring problem. Quiet thought, patient effort to understand those to whom we bring the message, sympathy one with another in trying to work out this problem, courage in forsaking old ruts combined with the true conservatism that holds tenaciously to unchanging truths — these are some of the qualities we need. If the N. C. C. cannot help the Christian forces in China in this matter, it will miss one of its largest opportunities. Yet we must all recognize that it is a sphere of activity beset with dangers, and only as we are led by the Spirit dare we seek to enter it.

(6) *The need for a frank discussion of Church Unity.* The N. C. C. is not charged with the duty of creating a united church for China and has no intention of setting out upon such a difficult task. Nevertheless many are thinking and talking about the problems which are sure to arise as serious attempts are made in this direction. If the N. C. C. can provide an atmosphere in which such discussion can proceed amicably and constructively it may render a very big service to the cause of Christ in this land.

(7) *The need of a better understanding of the problem of Missionary Training.* With all that has been done in starting Missionary Training Schools in the Field there is still felt to be an inadequate understanding of the problems and too little correlation between the various

parties concerned. The International Missionary Council has referred this matter to the N. C. C. which is now seeking to study the problem in consultation with those engaged in its solution and with Chinese Christian leaders.

To the above it would be easy to add other problems already on the horizon. But enough has been said to show that the Council will not lack for work within its well-defined sphere. It has only been functioning in any complete way for about a year, and it is far too soon to speak of the results of its work. By visitation and by literature, by its annual meetings and committee meetings, by its retreats and groups for research, it hopes to learn its task more and more. It relies upon the candid criticism, the sympathetic understanding, the willing coöperation and the loyal support of all whom it seeks to serve. If progress seems slow in some of these directions, may we have patience remembering that "He that believeth shall not make haste", and that it is better to do a few things well than to rush into a multitude of activities and leave many only half done. After all, in the last resort, the N. C. C. is what the Christian forces in China make it, and if, as we firmly believe, God is working in these forces surely the result will be to His glory and honour.

CHAPTER XX

THE NATIONAL CHRISTIAN COUNCIL AND THE CHURCH IN CHINA

L. J. Birney

Origin The National Christian Council was created by the National Christian Conference held in Shanghai, May, 1922. It is the successor of The China Continuation Committee and carries forward the work of that pioneer organization with increased vigor and effectiveness, having the added advantage of being constituted on a more truly representative order, and inspired by the tremendous impetus of the history-making conference which gave it birth.

Nature The Council in no sense stands in the relation of controller or director of church activities. It has neither been given nor does it desire authority in any degree. It is the servant of all individuals and churches who wish to avail themselves of its help in the interests of the whole Christian Movement in China, or of any specific phase of it. It is a "Council" of coöperation in the common Christian task of building the Kingdom of Heaven in China.

Aims and Tasks In the interests of all the churches and most of all of the growing indigenous Church in China, the Council seeks to perform among other services, the following:

Spiritual Life *The enrichment of the spiritual life of the Church.* Nothing of graver importance awaits the ministry of the Council. It is the conviction of many that the spiritual life and vitality of the Chinese Church has not kept pace with its numerical and territorial expansion. The Church of to-day is fixing the types and standards for the future. It is imperative that in the indigenous conception of the Church, the supreme emphasis should be placed upon the central characteristic of the true Christian Church in any age or country—its essentially spiritual

nature. This its chief service of spiritual stimulation, the Council seeks to render through evangelistic meetings, conferences and "retreats," in which church leaders in limited numbers spend unhurried days in studying the more vital Christian problems, seeking for themselves a deeper and more virile spiritual life that they may in turn bring new life to the churches they represent. Much good has already been wrought in many parts by these means.

Social Welfare *A study of social problems, moral and industrial, with the aim of bringing to bear Christian forces that will ameliorate the conditions already existing, and of preventing the growth of menacing social evils. The opportunity for exploitation of illiterate and desperately needy multitudes, the absence of a government interested in making laws that will protect the helpless, or in enforcing them if made, renders this problem an exceedingly difficult one, but in consequence all the more imperative. The Church is being made increasingly to feel its responsibility of leadership in this struggle for human justice. The Council stands strongly for,—*

- (a) No employment of children under twelve.
- (b) One day's rest in seven.
- (c) The safeguarding of the life and health of workers.

The problem of restraining and reducing the evils of prostitution, gambling, opium, etc. are distinct responsibilities assumed by the Council on behalf of the Church. Much effective work has been done in the way of research, publicity and the stimulation of interest and activity in relation to these threatening evils. Special committees are constantly at work on these varied problems and next to the deepening of the life of the Church, the Council will probably render its largest service in this field, seeking to achieve and retain for the Church a rightful leadership in social welfare — a leadership which the Church in the West has too largely sacrificed.

Rural Life *A more thorough study of conditions in Rural China and of the character, methods and possibilities of the country church. 66% of missionaries of China are in cities and towns of over 50,000 inhabitants.*

On the other hand, 85% of China's population is rural. The creation of an indigenous church is, in the mind of the Council, clearly dependent in large measure upon the development of the rural church. A Chinese writer traces the Lincheng affair in part to a well nigh total neglect, on the part of the Church, of the region responsible for it. However true this may be, his logic is sound. China's rural multitudes demand a far larger proportion of the Church's ministries than they have ever received, and the Council is endeavoring to lead the way. Definite study and visitation has begun and will persist until a well considered policy is possible on the basis of known conditions and needs.

Coöperation *More effective coördination and coöperation.*
The stimulation of the Christian forces of China to a closer and more sympathetic coöperation will vastly increase their effectiveness in achieving the aims common to them all. The idea of organic unity of missions, or of the constituent elements of the Chinese Church, is not within the purview of the Council. It takes the Chinese Church for granted as a living fact and seeks, so far as may be, to correlative and concentrate its energies, that the full united power of its momentum may be brought to bear upon the immediate Christian needs of China. That such a service is demanded is everywhere admitted and by the Chinese Church urged as imperative. There is no other organ except the Council in a position to embody and realize this universal desire. As it becomes a common bond in united effort, and therefore a common Christian witness to a non-Christian land, it will render one of its great services to the Church and the whole Christian cause in China.

Research and Information. The Council aims to become increasingly an effective instrument of research and a bureau of needful information touching the work of the Church in China. There are outstanding Christian problems that require the closest thinking and the most painstaking investigation. No one Christian body can do this work in any comprehensive way. It is more properly the task of such a servant of all the churches as the Council seeks increasingly to become. Here is being collected,

analyzed, and made available for use in further advances of the Christian army, the information accumulating from surveys, investigations, and programs-denominational and interdenominational.

Home Life In addition to these the Council aims to assist the Church in such important work as the creation of a more efficient Christian home life; the study of the relation of education to the Christian movement; the fostering of Christian international relationships and the opposition to war as a means of adjusting inter-provincial or international differences; to encourage in every possible way the creation and use of the right type of native Christian leadership. Detailed tabulation of what has already been accomplished in these lines of action is difficult and in many cases impossible, but the Council has made substantial progress in most of these, though it has been at work scarcely two years. With a staff which commands the complete confidence of all and an organization of undoubted efficiency, there is highest assurance of rapid gains in the immediate future.

CHAPTER XXI

PRESENT TENDENCIES IN THE CHINESE Y. M. C. A.

David Z. T. Yui

One of the elements of strength of the Y. M. C. A. as a Movement is, doubtless, its capacity to adapt itself to new conditions and to help meet new needs without sacrificing the cardinal points of its objective and organization. The first Y. M. C. A. was organized in England. It quickly found its way to Europe and North America, and later to Asia and other continents. A close examination of the Y. M. C. A.'s in these lands will reveal the fact that in the cardinal points they are much alike, but in programs they differ because of different environments and needs.

The International Committee of Y. M. C. A.'s of North America was responsible not only for the introduction of the Y. M. C. A. Movement into China, but also, through generous and continuous supplies of inspiring and experienced leadership, building funds, and of encouragement of various kinds, for its rapid growth and development. The Danish Y. M. C. A. Movement has of late years been of similar help to the Chinese Y. M. C. A. particularly in Manchuria. Several Christian missions in China have been generously coöperating by allocating some of their men to "Y" service at different times. To these, the Chinese Y. M. C. A. feels exceedingly grateful. At the same time, we should mention the keen and sincere appreciation of the Y. M. C. A. on the part of the Chinese people and their remarkable response which is no less important in achieving the success that we see to-day.

But, how can this apparently heterogeneous group of forces work so well together? It is because they have one common purpose; viz., to help build Christian character among the boys and young men of China. They have also one common conviction; viz., this important task

can be more easily and fully accomplished through the Chinese Y. M. C. A. in contrast to any foreign Y. M. C. A. In addition, they have persevered in pushing the development of the Movement in this direction without change or serious deviation. The International Committee and other movements or missions gladly and conscientiously support the Chinese Y. M. C. A. in various ways and at the same time respect its autonomy. The Chinese Y. M. C. A. shows deep appreciation of the friendship and coöperation of these agencies and is faithful and enthusiastic in shouldering its responsibilities for the Movement.

What are the present tendencies of the Chinese Y. M. C. A.? The above comments already indicate the general direction in which the Chinese Movement has been developing. No attempt will be made here to describe the regular work which the Chinese Y. M. C. A. seeks ever to improve and enrich. For clarity, we shall bring out the tendencies as we see them under two groups:— First, those which help meet some present needs; second, those which enable the Movement to accomplish its task more efficiently.

1. The Chinese Y. M. C. A. has, from the beginning, recognized the tremendous potentialities of the student class in relation to the present and future of China, and has shaped its policy and program accordingly. Much hard and good work has been done. Unfortunately, conditions in the country in general and in schools in particular have, for the last decade or more, affected students in a very serious manner. Their minds have on the one hand been thoroughly intoxicated by the different "isms" and "ologies" from abroad which are often presented in inadequate and distorted form and hence are poisonous and dangerous, and on the other hand they have been stirred to the very depth of their hearts by the corruption and disintegration which they see around them. The general world situation is no less responsible for this restlessness. Their life in many ways is in a most appalling state. The devil by the name of "Legion" has been and is still busy, and countless youths have fallen and are falling into his deadly clutches

every day. What are we going to do? The challenge of the student work of to-day demands new, redoubled and more concerted efforts on the part of the Chinese Y. M. C. A. and all other Christian agencies. The Chinese Y. M. C. A. and also the Y. W. C. A. are strongly convinced that the following should be carried out without delay: — (a) To enrich the program of the student work to help meet the present urgent and challenging conditions; (b) To seek for greater coöperation with the churches in order to man more adequately the field and also to identify more closely the students with the churches; and, (c) To create a national Christian student consciousness among the student Y. M. C. A.'s and Y. W. C. A.'s, which consciousness should be a powerful impetus to the work.

2. We recognize that the development of industries has greatly profited the peoples of Europe and America, and we are equally aware of the terrible effects of industrialism among these same peoples. China is now on the threshold of her industrial development, and we should indeed welcome this new era. Shall we not, however, profit by the experience of western countries by reducing to a minimum the evils of industrialism? Already, lock-outs, strikes, etc., have found their way to China, and the horrors of child-labor, long working hours, low wages, unsanitary working conditions, though on a much smaller scale, are by no means less intense. The Chinese Y. M. C. A. feels a distinct call to enter the industrial field of service, although it is not prepared to-day to plunge itself head-long into it by borrowing a program from some foreign countries irrespective of differing conditions and problems or by trusting to luck for good results. No time has been lost. The Chinese Y. M. C. A. has been quietly studying the industrial situation in the large cities; earnestly trying to have men trained both in China and abroad for this service; and faithfully conducting experiments in a few well-chosen centers to gain experience. Efforts have repeatedly been made to secure a few experienced industrial secretaries from Europe and America to guide the Movement; these have not met with success. The Chinese Y. M. C. A. believes

that it has been following a wise and constructive policy in this matter, but feels also that it has yet much to learn from its studies and experiments. It will probably therefore follow this course a while longer. Meanwhile, the Chinese Y. M. C. A. is pleased to coöperate with other organizations in studying and experimenting in the industrial field of China for the purpose of rendering much-needed service. It also wants to draw as many lessons as possible from the experiences of industrial workers in other countries. It will fearlessly tackle this job as soon as it has gained a clear conception of what its service should be and how best it can be done.

3. One of the most serious hindrances to the rapid growth of democracy in China is, of course, the appallingly high percentage of illiteracy among her 400,000,000 people. How can the Republic develop when the overwhelming majority of the people cannot read or write; do not possess the fundamental knowledge of modern life in all its aspects; are not aware of their privileges and responsibilities as citizens; and even refuse to take an active interest in the welfare of the country? On the other hand, we have to remember the hundreds of dialects which are keeping our people apart, the former education which narrowed our minds to a mere form of literary gymnastics, and the very difficult written language which we have to learn. We should also consider the important fact that our people have been living under an absolute form of government for many centuries and have, therefore, been taught by bitter experience to have as little as possible to do with the affairs of the country. These constitute, however, no excuse against introducing improvements at this time. The Chinese Y.M.C.A. feels that it has a special contribution to make. Our lecture work on science, education, public health, and other topics with specially invented apparatus for demonstration and with charts and lantern slides for illustration has been reaching thousands upon thousands of people each year, and the success of this work for enlightenment is exceedingly encouraging. Recently, a method consisting of the teaching of 1,000 "foundation characters" scientifically and empirically

selected has been devised by Mr. Y. C. James Yen to break the backbone of illiteracy and to provide the masses with a simple key with which to unlock and secure the knowledge they must have. This method, in the few demonstrations thus far conducted, has proved a success. The level of general intelligence among the people must be raised and kept on a high plane. With demonstrated and illustrated lecture work, with the simple tool of 1,000 "foundation characters," and with other supplementary means, the Chinese Y.M.C.A. hopes to be able to teach the Chinese people "Citizenship" not only in China and the world but also in God's Kingdom. It aims not merely to enlighten the mass of the Chinese people on what citizenship is, but also to apply the principles of Jesus to every-day living. The Chinese Y.M.C.A. feels keenly its responsibility for the masses of the Chinese people along these lines and will make ever greater efforts to serve.

4. The Chinese Y.M.C.A. is to-day projecting itself more and more into the field of international service and coöperation. That it ought to have a large share in creating a consciousness of world-wide brotherhood has been brought home vividly and successfully to the Movement during the last few years. The 11th Conference of the World's Student Christian Federation held at Tsing Hua College, Peking, two years ago, with its wonderful fellowship among the student delegates of many nations, produced a most wholesome effect on our student mind. The after-conference tours by the foreign delegates left a permanent impression on the entire Movement. The rest of the world remains no longer a mystery. Not only that, mutual admiration and appreciation have been fully awakened, and the relationship of mutual service has been growing in strength ever since. Mr. T. Z. Koo was called to be the first Oriental Secretary with head-quarters in Europe, and he will proceed to his post this summer. Last year, under the auspices of the Federation, Mr. Koo visited India and met with her student leaders in many centers. It has been reported to us from many sources that no man, oriental or occidental, has made a more effective and helpful impression upon the Indian student mind than Mr. Koo. In the

spring of 1923, the World's Committee, which is composed of the National Y. M. C. A. Movements of different lands, held in Hungary a World Conference on Boy's Work, which Mr. M. T. Tehou went especially from China to attend on behalf of the Chinese Y.M.C.A.. He played a very important part at the Conference. We shared our problems and experiences in boy's work with the rest of the world, and in turn we learned much. Early this fall, the Chinese Y.M.C.A. will participate in the Conference of the National General Secretaries which has been called by the International Committee to be held in America. This will afford added opportunities of studying our common task from an international stand-point and exchanging our experiences. We cannot lay too much emphasis on the importance of our entering whole-heartedly this field of international service and coöperation, aiming at creating a world-wide brotherhood without which international understanding, coöperation and peace can hardly be realized.

We shall now come to the second group of tendencies which go to enable the Chinese Y.M.C.A. more efficiently to accomplish its task.

1. Leadership is the first essential in the success of any organization or movement. For thirty-seven City Y.M.C.A.'s and one National Committee, we had in 1922 altogether 550 secretaries as compared with 478 in 1921. On the surface, it naturally seems that the Chinese Y.M.C.A. is well supplied with secretaries, and the number is increasing in accordance with the growing work. We have every good reason to be thankful for the men now in the secretaryship. At the same time, we feel painfully the fact that we are not able to measure up to the opportunities of expanding service pressing upon us on every hand. We have been appealing to the International Committee and sister movements in other lands and several Christian missions in China to assign, loan or allocate to our work men of the best preparation and highest consecration. The Chinese Y.M.C.A. greatly needs these men because of the distinct and permanent contribution they can make; viz., training and reproducing themselves in their Chinese associates. No service is nobler or more fundamental to

the permanency of the Chinese movement than this. Meanwhile, the Chinese Y.M.C.A. is not sparing itself in developing Chinese leadership. The supply of leadership from other countries cannot but be limited in numbers and can never be equal to our unlimited demands in view of the immenseness of our field and the complexity of our work. The natural growth of the Chinese Y.M.C.A. will devolve more and more upon the Chinese secretaries. Already we have Chinese General Secretaries in seven or eight of our City Associations, and the number of Chinese Departmental Executives is increasing even more rapidly. Our foreign secretaries have indeed excellent reason to congratulate themselves on the real success of reproducing themselves in their Chinese associates. We should quickly point out our urgent need of more and even stronger foreign leadership as well as its permanent place in the Chinese Y.M.C.A. In fact the terms "foreign" and "Chinese" secretaries are certainly misleading. We want to state emphatically that there is no such distinction in the Chinese Y.M.C.A., for we know of no racial or national differences. All secretaries are on an absolutely equal basis, and are working for the same cause. Because of different temperaments, training and experiences, they supplement one another in a wonderful way, and have, as a rule, affectionate regard for one another. This is indeed an element of real strength which should be preserved at all costs.

2. To a casual observer, the Chinese Y.M.C.A. appears to be merely an efficient organization full of activities. This is a real compliment. The implication is, however, that the Chinese Y. M. C. A. does not make much use of its brains. The reason for its success thus far is the presence of the foreign secretaries who have been borrowing successful Y. M. C. A. methods from abroad and have been applying them equally successfully in China. To many who know the Chinese Y. M. C. A. better, the above criticism betrays ignorance. As a rule, each local association has two setting-up conferences in the early spring and fall of each year to discuss thoroughly the policy and program of the association and to set up carefully the program of the term. There are daily meetings and weekly conferences to check up and improve the program if necessary. We

have regular meetings for our Directors and committee men, and also special retreats for them from time to time. The National secretaries visit the local associations not only to assist in their activities but also in their studies by drawing upon experiences in other centers or countries. Regional conferences and retreats each year and National Conventions and Employed Officers' Conferences once in three years are all intended for educational and spiritual purposes. This is not enough. The Chinese Y. M. C. A. feels the importance of starting a Research Department whose function will be not only to study the problems as they come up, but also to investigate and experiment in new fields and new lines of service which conditions in China will call for and which may not be found in the policy and program of other movements. We should not take things for granted, nor accept anything from abroad without examining the same in the light of our own conditions and needs. The Research Department will study Chinese civilization to find out the good qualities to be re-awakened and brought into the reconstruction of our country. It will also scrutinize western civilization so that our young men and boys will be warded off from the evils therein and will be benefited by the good in it. Not only should we re-evaluate everything but also have the courage to venture into the unknown and experiment. Only in this way, can we really make progress. The Chinese Y.M.C.A. believes in this Research Department and its great possibilities, and is making plans to install it at an early date.

3. Some people criticise the Chinese Y. M. C. A. for not being religious enough, and its religious work is looked upon as superficial and indefinite. Others decline to help the Chinese Y.M.C.A. because it is a religious organization. Two years ago, on the opening day of the magnificent building of the Ningpo Association in Shanghai, one of its directors remarked to a group of foreign visitors that in that building they had everything a well-equipped Y.M.C.A. usually has except religion. Opinions differ. May we refer briefly to a few statistics of the religious work of the Chinese Y. M. C. A. ending December 31st, 1922 as follows:—

Bible-study Classes	3,431.
Enrollment in these classes	36,999.
Religious Meetings	5,008.
Attendance at these meetings	628,391.
Men and boys joining churches	3,174.

We should by no means over-emphasize these figures which simply serve to show the general situation. In reality, they should sober us to a sense of greater responsibility for the religious life and activities of our members, when we see our failure to reach less than one half of them, their number in 1922 being 77,947. The Chinese Y. M. C. A. is not at all satisfied with the results thus far, and is endeavoring to deepen its religious life in every possible way. Greater efforts will be made to push Bible-study classes, religious meetings, and personal work. More helpful devotional literature will be prepared and placed in the hands of our members and those with whom we come into contact. A series of local and regional retreats are now being prepared for this spring and early summer especially with the leadership of Mr. F. S. Brockman, Dr. H. T. Hodgkin, Rev. K. T. Chung, Mr. T. Z. Koo and others. We shall more faithfully promote prayer, meditation, and practice of the presence of God. It is imperative that we should feed our spiritual life, if we want it to grow. How many of us often allow our spiritual life to starve without even feeling the pangs of hunger? Not only that, we should exercise or give expression to our spiritual life in service which is just as important as spiritual feeding. A spiritual life without expression is as dead as the Dead Sea. The Chinese Y.M.C.A. feels the urgency of vitalizing and spiritualizing every phase of its work and also every worker, be he director, secretary, committee-man, or member, and is endeavoring to work in this direction. The service of the Chinese Y. M. C. A. can be as effective only as the religious life is filled to overflowing with the grace of God.

CHAPTER XXII

SOME MODERN ASPECTS OF THE YOUNG WOMEN'S CHRISTIAN ASSOCIATION IN CHINA

Based on material given by Mrs. T. C. Chu and Miss
Ting Shu-ching, and prepared by Theresa Severin.

**Student Work
Commission** The year 1923 is a significant one in the history of the Young Women's Christian Association in China. In the spring of the year a National Student Work Commission met in Shanghai in April and after days of discussion and thinking together prepared a Statement of Purpose and Basis of Membership in Student Associations, and plans for program, which were sent out to Student Associations all over the country in order that there might be the fullest possible thinking on these lines before the National Convention of the entire Association called for October of the same year. The Purpose as thus discussed and presented to the Convention, and formally accepted by them was as follows:

- I—Based on Christ-like friendship, to unite the members through Bible study and prayer to know deeply Jesus Christ as the highest revelation of God, perfect example of man and Saviour, and to copy his way of living.
- II—To lead students to share the friendship of this movement in order to advance their character, step by step to understand Jesus Christ clearly, to be an active members in the Church, and with united strength to help meet the needs of society.

The Convention also voted that any student who expressed approval of the Purpose of the Association might become a voting member, thus challenging all who wish to participate in the work of the Student Association

to pledge themselves to a deeper loyalty to Jesus Christ for themselves, and to share with others that knowledge in such a way as to lead others into the same active loyalty.

National Convention The calling of the First National Convention for Association members was the goal to which the leaders of the Association had been looking forward for years. The results of the Convention proved in a convincing way that the goal of to-day is but the signpost pointing onward to a goal more distant. Perhaps this struggle to steadily move forward to an ever receding goal is the genius of the Association movement everywhere, but during those October days the one hundred and fifty delegates, representing City and Student Associations all over China, were pledging themselves to programs of endeavor which could only be accomplished with the bringing in of the Kingdom of God itself.

A glance at the recommendations passed at this Convention gives one some idea of the scope of the Purpose of the Association. Leading women into a fuller knowledge of Jesus Christ means an interpretation of the practical application of His principles of life. Therefore it is not strange to find recommendations that the Association cooperate with all existing agencies in campaigns against Foot-Binding, the Planting and Sale of Opium; that it should work constructively on plans for Popular Education, Recreation, and Health Campaigns. The appeal from the National Christian Council that we cooperate with it in its effort to meet the industrial problems in China was most heartily endorsed by the Convention. That such endorsement was not a matter of mere words is testified to by the fact that the national Industrial Secretaries of the Association movement are working directly under the Industrial Committee of the National Christian Council.

Relation to Church This note of cooperation was the one that was being continually struck, no matter what particular problem was being faced. Underlying all the discussion and thinking was the desire to have the life of the Association express itself through the Christian Church. The methods of such expression

must necessarily vary in different places, depending on how far the church in any center has gone on the road to unity of effort, but in certain cities the Association has been asked to use church equipment in making its contribution to the girlhood and womanhood of that section of the city. This desire that the Association should lose itself wherever possible in the life of the Church is deep in the hearts of many of the Association leaders. This is especially true of Miss Ting Shu-ching, the Acting National General Secretary for China.

**Chinese
Leadership**

Miss Ting's coming into this position is another evidence of the significance of the year 1923. For the first time our National movement is going forward under Chinese leadership in the chief executive position, and there are daily evidences of the power of that leadership. Miss Ting is convinced that the Association movement offers a unique opportunity to Chinese women to work together in making a Christian society. No one understands more fully than she the splendid capacities of Chinese women for service. But recognizing that in many instances their efforts are too isolated she is eager that the opportunity be given them of working together.

Interpretation

The interpretation of the work and place of the Young Women's Christian Association in China as given by Mrs. T. C. Chu, former Chairman of the National Committee, gives further evidence of the leadership that is being given to this movement by the women of China. She writes:

"The official name of our Association is the Chinese Young Women's Christian Association. Putting Chinese in front of the name makes the distinction from the Association of other countries, and adding the word Christian emphasizes the aim of our Association, which is to guide women to God and to follow Christ. We sincerely believe that to serve others is absolutely necessary in a wholesome life for the individual, and to sacrifice oneself is necessary in developing social happiness. This is the spirit of Christianity! Only the women who are sincere and who live by the truth of Christianity can have this spirit."

As evidence of what the Association means to its membership I would again quote Mrs. Chu:—

“Though the volunteer workers help without salary they do get in return a benefit which cannot be purchased with money. Women with ability and wisdom ought to use it. Now in China the women are not allowed to go out to work. People do not understand that human beings were created to be useful. Women are kept at home as something precious and they are not allowed to know life outside. The volunteer workers of our Association are the fine women of the country. If it has been said that students trained in the mission schools and the returned students can work more harmoniously with foreigners, because they have had more association with them, it is wrong! The Y.W.C.A. is one of the cooperative movements of the world and it is the greatest movement among women of these times. The international movement for suffrage for women and the Federation of Women Laborers works no better than our Association. Can we women of the Chinese Republic boldly go forward as do the women of other civilized nations?

**Volunteer
Workers**

This is not all. All the volunteer workers can receive group training and learn the spirit of cooperation, because anything that is to be done will be put in the hands of appointed committees. The elected president is simply an officer standing for other people and she can never do anything by her own will. The co-workers, with varying ability, can work together happily. This is the very aim of our Association and we fully believe that it can be of help to the people of China. The trouble in China now is not due to a lack of able people, but to a lack of coöperation among able people. If we want to reform this wrong, we must first of all work among women. Any sort of work in our Association demands cooperation.”

Growth

Thus at the close of 1923 we find a woman's movement which started barely twenty years ago now reaching out through twelve City Associations and ninety Student Associations, under leadership increasingly Chinese; a movement which by virtue of its first National Convention has become a national movement endeavoring

to so express the spirit of Jesus Christ that women of all classes shall be drawn to Him as giving that fullness of life which is the birthright of all the children of God.

During the early years of the Association's history in China most of the activities were planned for and directed by the educated women of leisure, but steadily there has been a reaching out to all classes and all ages with a growing eagerness to bring to younger girls a truer conception of God and their relation to Him. Even more significant was the recommendation passed at the Convention that membership in the Association should not be limited by nationality, so that in looking ahead to future days one realizes that the Young Women's Christian Association of China may, if it faces its task with sufficient humility, be a very tangible expression of the oneness of all life in Christ.

CHAPTER XXIII

CHINESE HOME MISSIONARY SOCIETY

Missionaries In the fall of 1922 the Society sent Dr. L. K. Liu to Yunnan, making a total of ten missionaries working in the three centres of the Yunnan Mission. In the early spring of 1923 it accepted, with great reluctance, the resignation of Dr. T. C. Hsueh who is now working with the Episcopal Mission in Yunnanfu. Later in the spring Miss Li Mu-chen's health failed and she was ordered by her doctor to leave the south and return to her home in the north. But the change did not benefit her and she was called to her eternal rest on the twenty-second of September. Another resignation was forced on the Society when Miss Hope Hsu became engaged to a young man in Ko-kiu who was brought to Christ through our missionaries. The marriage took place in October and the Society's loss of a valued worker is Ko-kiu's gain in a Christian family.

Yunnanfu In this provincial city there have been three missionaries, two women and one man. They have been engaged in educational work mainly. The schools are a primary for girls, a primary for boys, and a kindergarten for both boys and girls. The enrollment for the year in the three departments was one hundred and thirty. Seven girls finished the primary course and entered the higher primary school. Five came to Shanghai to study in the Bethel Mission and one went to Hangechow. Four girls from the primary school were baptized during the year. Through the girls the women missionaries got in touch with many women of leisure in the city. The missionaries give time to the study of the home life and environment of these women and thus learn their needs. They organized in August, 1922, a philanthropic society, the aim of which is to arouse greater interest in the welfare of others, encourage a proper use of time and money and develop individual talents. Within the short space of a

few days, the members raised six hundred dollars among themselves and started a school for the blind. For this school they secured a teacher educated in Canton. Ever since its opening the financial burden of this enterprise has been carried by these women, missionaries having assumed the executive part. A few classes in Bible Study were started in Government Schools.

The year's church records show a goodly number of probationers and the baptism of several men.

Lu-feng It was through the medical department that missionary work was welcomed in Lu-feng. For the greater part of the year two doctors were there, one woman and one man; their time was given to dispensary work and evangelistic calls. The average daily clinic was more than thirty and the calls were courteously received. After Dr. Liu left for Ko-kiu, the work was carried on by Dr. Lin Chieh-en alone with such help as Miss Chen Yu-ling and Mr. T. S. Chen could give.

A half-day school for women was opened by Miss Chen. There were nineteen pupils who were taught to read and write, do useful handwork, and, most important of all, to study the Life of Christ. In addition to the work above mentioned visits were made to the prisons for both men and women, meetings held with the soldiers in camps, and classes taught in Government Schools. Six baptisms and a long list of probationers are some of the results of the year.

Ko-kiu The work in Ko-kiu was started a year ago. Dr. T. C. Hsueh was the pioneer worker. He opened a dispensary and was joined by Mr. Chang Chuen-hsin and his family and Mrs. Lu Siu-mei. The latter was called back to Yunnanfu by Miss Li's illness and Dr. Liu took Dr. Hsueh's place after his resignation.

So many changes have hindered this work that no fair report can be made of this young enterprise.

Heilungkiang Long before the Chinese Home Missionary Society came into existence the Chinese Christians of the Presbyterian Mission in Manchuria had started home mission work in Heilungkiang. A unique piece of work was done there. But in the early part of 1922 this work was affiliated with the Chinese Home

Missionary Society and is now called the Heilungkiang Mission. Later a main auxiliary was organized and located in Harbin with two salaried officers, a general secretary and an assistant. The budget for the work and the office expenses is raised entirely through the branch auxiliaries of the three Manchurian provinces. This includes one hundred dollars given yearly to the C.H.M.S. for its annual budget. Besides the help given by the Christians of the churches started by this mission, there are seven missionaries connected with this society. The whole amount collected for the year was \$8,396.35. The number who take communion is forty-six.

Auxiliaries There were thirty-four new auxiliaries organized during the year, making a total number of fifty-eight. The Manchurian Auxiliary alone has over eighty branches; another one has about fifty.

Finance Full particulars of receipts and expenditures are not now available. The yearly budget of more than twenty thousand dollars was met by contributions from auxiliaries, Christmas gifts, group gifts and individual gifts. A few of the gifts were from foreign friends. All conference expenses were covered by the Milton Stewart Fund.

CHAPTER XXIV

HUNAN BIBLE INSTITUTE

Frank A. Keller

For an account of the beginning of this work and its growth during the early years the reader is referred to the article "The Hunan Colportage Work of the Bible Institute of Los Angeles" in the China Mission Year Book for 1917, pages 353-357.

The Hunan Bible Institute is the China Department of the Bible Institute of Los Angeles and its work is carried on along three main lines:—1. A Bible School at Changsha. 2. The Biola Evangelistic Bands. 3. An Autumn Bible Conference at Nanyoh.

The Bible School This Bible School was started in response to a most urgent need and its growth has been remarkable. The original plan was to begin classes in the fall of 1918, but the Rev. W. S. Horne, principal of the Burrows Memorial Bible School, was summoned home on account of the serious illness of his wife, he had a small class nearly ready for graduation and he asked us if it would be possible to open our school in the spring, and receive and graduate his class. God enabled us to do this and the regular school work was begun in the spring of 1918 with the class from Nanchang and a few local students.

The school has grown steadily and we now have one hundred and twenty-seven students who have come from twelve provinces and represent eighteen different missions.

The course of study leading to a diploma requires two years. Each year's work is separate, making it possible to have smaller classes and to give more personal attention to each student. This plan necessitates a much larger staff of teachers than is required by the "two year cycle" method of most Bible Schools. Our present staff consists of twelve Chinese and nine foreign teachers, and we hope to increase the number in the near future.

**Work of
Students**

The twelve missions in Changsha offer rare opportunities to our students to make a thorough study of all kinds of church, evangelistic and Christian educational work, and also to engage in the various branches of work in the church of their choice under the direction of the missionary-in-charge. Our own street chapel, "Biola Hall," and the street chapels of the several missions make it possible to give to our students a practical training in preaching that is of the utmost value.

Three afternoons each week the students go out two by two to visit in the homes. Interested persons are invited to attend the nearest church on the following Sunday and the students offer to escort the enquirers to the church and introduce them to the missionary and pastor.

**Vacation
Evangelism**

During the winter vacation of one month and the summer vacation of two months the students are organized into evangelistic bands, and go out into various fields on the invitations of the missions responsible for those fields. During our last school year, including the vacation periods, our students visited 24,117 homes and had the joy of leading many to a definite faith in Christ.

**Milton
Stewart Hall**

The "Milton Stewart Hall" now under construction, with its large auditorium, splendid class rooms, lecture halls, reading rooms, library, and offices, will add greatly to the efficiency of the work. In the dormitories each student has a separate room, thus giving opportunity for the private Bible study and prayer that mean so much to the growth of a soul.

**Biola
Evangelistic
Bands**

The word "Biola" is formed by using the initial letters of the name of our home institution, Bible Institute Of Los Angeles, B. I. O. L. A.

The Biola Evangelistic Bands are each made up of twelve men and a trained leader. Our special work is PERSONAL EVANGELISM in the homes of the people, mainly in unevangelized districts. The bands, when available, are sent to the fields of various missions on the

written invitation of the mission concerned, our main conditions being that the bands be allowed to work in new districts, and that the work be consecutive and thorough.

Daily Bible Study A most important feature of the work is the daily morning united Bible study under the direction of the band leader. An hour and a half every morning is devoted to this Bible class which is attended by every man in the band, and the lessons have to be carefully prepared. Interested enquirers are invited to this class and so they learn the joy and value of systematic Bible study from the very beginning of their Christian experience.

Day's Work After their morning Bible study the men go out two by two to visit in the shops and homes. They invite the people to the evening evangelistic service and as soon as people become interested they form them into classes for Bible study. They organize classes for men, for women, for students and for children. They teach important texts and stirring hymns to the children, and after a band has been in a center for a few days the children all along the street are singing out the Gospel message from morning till night.

Missionary Report A missionary of one of the largest missions in Hunan in a recent letter to his home mission paper wrote: "We secured the promise of a Biola Evangelistic Band for our district and looked forward to their coming with great expectations.

"After Chinese New Year they began work. They went up and down the streets visiting every home and inviting people to the meetings.

"The leader of the band got a group together for regular Bible study, and he kept that class going through the whole spring; in April 60 persons entered our catechumen's class.

"We also saw the fruit of their work among the Christians of our church, they became more eager to win others to Christ and more people attended the Sunday services than ever before.

"Those young evangelists were indeed an example to all of us, whatever the weather, snow, rain or burning sun they went around in the country and villages with their books.

“ Their way of living is very simple, they take only two meals a day, they neither smoke nor drink wine. Every morning at six o'clock the bell rings for the morning watch. They always looked happy and they carried their joy into the homes they visited. It was quite an experience to do house visiting with them: many sick and bed-ridden people were converted and baptized during the stay of the band with us.”

**Chinese
Leadership**

It is important to note that the bands are under Chinese leadership, no foreigner goes out with them, though missionaries in whose districts they are working are invited to visit them and so are brought in contact with the converts.

The bands are supplied with a number of the best religious publications which keep them in touch with Christian work all over the world. The men are all systematic givers, making contributions regularly to various Christian enterprises, and they teach their converts the duty and joy of giving. The work has resulted in the establishment of many indigenous, self-supporting and aggressive churches.

We now have twelve bands (156 men) working in three provinces. Last year ten bands visited 232,241 homes and gave out 890,726 Testaments, Gospels and other Christian literature.

Bible Conference

Every year we spend the month of September at Nanyoh, one of the five so-called Sacred Mountains of China. There are three lectures or classes each morning, and occasional additional lectures when called for. The afternoons are devoted to rest, correspondence and personal work among the thousands of pilgrims who come to Nanyoh to worship at the shrines.

There is a fine swimming pool with sand bottom which the men enjoy greatly, and there are pleasant walks in various directions.

This work was begun in rented quarters, but it grew so rapidly that we were compelled to purchase a site and erect suitable buildings. We now have a grand site and buildings which will accommodate five hundred delegates.

Last September, in spite of severe war conditions, 370 attended the Nanyoh Bible Conference, some of them having come from such widely separated provinces as Shantung and Kwangsi, Szechwan and Chekiang.

Nanyoh is a place where Christian workers from various fields can meet, talk over their respective methods, problems, failures and successes, and unite in prayer for the one great work to which they all have given their lives. There is no rush at Nanyoh, and there are practically no distractions, therefore the visitors have ample time for conference, meditation and prayer. It is a joy to see individuals and little groups of men going off to some quiet spot on the mountain side, and the songs that come down from one and another of these little groups truly stir the soul.

The last Sunday at Nanyoh is a day long to be remembered, it is a practical demonstration of genuine Christian unity.

Missionaries from several lands, and Chinese Christians from many provinces of this great land, and from many different denominations, come together on this Sunday morning and, forgetting all differences of race and creed, with hearts truly knit together in Christ, unitedly partake of the bread and wine "In memory of Him", the great Head of the one body, the Church.

Mr. Lyman Stewart This article would be incomplete without a grateful and loving testimony to the faithful friendship, persistent efforts, earnest prayers and sacrificial giving of the late Mr. Lyman Stewart. To his vision and enthusiasm the work owes its start. Through the generous gifts of himself and his brother, the late Mr. Milton Stewart, together with the gifts and prayers of many loyal friends throughout the world, the work, by God's blessing, has reached its present position.

CHAPTER XXV

COÖPERATION IN THE C. I. M.

D. E. Hoste

Internattonal As is generally known, the C. I. M. is composed of workers drawn from different countries, denominations and walks in life: in these particulars, it is highly heterogeneous. That this tends to render coöperation between the members more difficult may be admitted. On the other hand, if such coöperation can be realized, the resultant life and action will be the fuller and more complete because of the diversity of the component parts. Further, it is good for character to learn to adapt ourselves to the habits and thoughts of those with whom previously we have had little, if any, contact. The prejudices, — often mistaken for principles, — which lead people to over-value their own ways and under-value those of others, are generally the result of restricted experience and a narrow outlook. Their removal, or at least their mitigation, is an essential part of education. Hence, what at first sight may appear to be a drawback in the personnel of the C. I. M., proves, when taken in the right spirit, to be a means of good and of enlargement.

**Belief, Aim
and Method** It is obvious that at the basis of any active organization there must be a common stock of objective belief, aim and method. In the case of missions, the ecclesiastical order and doctrinal tenets of a given denomination generally furnish the pattern. This means that, in some instances, liberty of thought and practice are restricted in respect of ecclesiastical order, considerable diversity of theological thought being permitted; in others, the reverse may be the case. Whatever abstract objections may be made to such arrangements, in practice they safeguard the convictions and provide for the religious liberty of widely varying types of workers. If, for example, a member of one denominational mission,

who embraced the ecclesiastical tenets of another, were, in the name of religious liberty, to be allowed to modify the church order of the former, the real result would be an infringement of the religious liberty of those who started or joined the organization on the understanding that its church order was to be of a certain type. The one whose views have altered is perfectly free to join some other organization in harmony with those views, or to work independently. He cannot, in reason, expect that the convictions of those abiding by the original understandings of the mission should be sacrificed on his account. Hence, the practical advantage of having a variety of organizations, each of which admittedly only covers a limited area of conviction and order. The alternative would seem to be either a fixed central authority for the whole Christian Movement, under which liberty of thought and independence of action became atrophied; or virtual anarchy, breeding confusion and ending in dissolution. The blessings of coöperation are great and various. They are, however, obtained too dearly at the expense of conscientious convictions. It is true, that any form of coöperation requires some sacrifice of individual thought and preference; but that is a different matter from the stifling of conscientious belief. This is not a question of charity, but of keeping a good conscience. It is of little use for me to tell my friend that the matters about which we differ are really immaterial. That may be true enough as I view them; but I must, in justice, to say nothing of charity, respect his right conscientiously to view them as essential.

Doctrine

In the case of the C. I. M., the foregoing principles find their expression in a common understanding as to doctrine, which, in the light of present day thought and speculation, may be regarded as strict and conservative; whilst in respect of denominational tenets, it allows full liberty within the compass of the generally recognized churches of ecclesiastical bodies of Protestant Christendom. The Mission has not a full, comprehensive creedal statement of its own. That would hardly be consistent with its interdenominational character. It simply interprets certain great doctrines of the Christian

Faith, in what has been recognized by all the great denominations as the strictly conservative and evangelical sense. These doctrines are:

- (1) The divine inspiration and consequent authority of the whole canonical Scriptures.
- (2) The doctrine of the Trinity.
- (3) The fall of man, his consequent moral depravity and his need of regeneration.
- (4) The atonement through the substitutionary death of Christ.
- (5) The doctrine of justification by faith.
- (6) The resurrection of the body, both in the case of the just and the unjust.
- (7) The eternal life of the saved and the eternal punishment of the lost.

It may be added that, in view of present day ambiguity of thought and language, the directors and councils of the Mission have recently thought it well to reaffirm their agreement with the strictly conservative and evangelical interpretation of the above, as stated by Mr. Hudson Taylor, with the concurrence of the councils of the mission, at the time of his retirement from the office of general director at the end of 1902.

This feature of the Mission clearly involves a marked restriction of its membership in some directions; at the same time imparting to it a largely homogeneous character, both in respect of doctrinal belief and the type of personal piety within it.

Practical Unity The Mission being interdenominational, the church preferences of its members are respected, each worker being sent to a district where his views prevail. In this way, Episcopalians, Presbyterians, Baptists, Methodists and Congregationalists are able to work within the fellowship of the Mission without compromise of conviction. Experience shows that practical unity is best secured by frankly recognizing and providing for differences of view. Attempts, however well meant, at an outwardly closer union, which either ignore or suppress sincere belief, lead, later on, either to disruption or to that deterioration, intellectual and moral, due to trifling with conviction.

Most people will agree that, after all, the question of coöperation is sometimes most acute as between workers in the same station or district. It is, indeed, only in so far as the Christian spirit prevails, that these relationships can be maintained as they should be. Here, as in other matters, it is the spiritual that is the truly practical. It is only by giving secret prayer and the devotional study of Holy Scripture their due time and place in the program of each day, that a Christian worker can be maintained and renewed in that living fellowship with God in Christ essential to fellowship with his brethren. We are so made that it takes time for us to receive the correction and the inspiration which the Spirit of God is prepared to give us. The words of our Lord to His disciples, "The Kingdom of God is within you," are still true. Perhaps the most dangerous result of neglecting sedulously to cultivate the personal Christian life, is that the one affected is largely insensible to the loss of tone and quality of his personality, which may be painfully evident to others. It is a commonplace to say that prayer and secret devotion are important: too often, however, we virtually contradict the words by adding that it is impossible to find time for them. This simply means that, as a matter of fact, we do not regard them as of the first importance. As a rule, we allow at least an hour and a half in the day for the nourishment of our bodies. Why should we expect our Christian life to be strong and helpful to others, if less time is given to secret devotions? "How shall we escape, if we neglect so great salvation?" The more we pray, the more we want to pray; the converse is also true. This often means cutting out of our schedule things, which good in their way, are taking the place of the best and highest. Fasting, the need of which was on more than one occasion, emphasized by our Lord, is not necessarily to be restricted in bodily food. One of its advantages is that additional time is thus gained for waiting upon God, and we may be sure that as we thus give practical evidence of our desire to draw nigh to Him, He, in His grace, will not fail to draw nigh to us.

CHAPTER XXVI

CHURCH FEDERATION IN CHINESE CITIES

J. S. Burgess

If the national organizations of the church federate, but the local churches fail to work together much of the national effort is of no avail. Plans projected at national headquarters in Shanghai become of little value without local organizations to carry them out. This was the verdict of the China For Christ Conference in Shanghai, in December of 1918.

Since this Conference it cannot be said that the federation movement has grown rapidly. In several places, such as Nanking and the Wu-Han district, there has been a notable increase of federated activity. On the other hand the splendid plans instituted in Tientsin three or four years ago have not accomplished what was hoped of them. The same is true in Peking.

The Nanking Church Council is perhaps the most successful local church federation. It took shape on New Year's Day, 1919, at a missionary prayer meeting. Its objective as stated by Dr. P. F. Price, executive secretary, brings out clearly the purpose of such federation:

"The closest possible co-operation between the evangelical denominations, at the same time respecting each other's denominational autonomy.

"Endeavoring to develop all the latent resources of the churches.

"Endeavoring through mutual consent, to find a place in city evangelism for each worker

"Aiming to be 'all at it, always at it, unitedly at it',

"The prosecution of a 'continuous evangelism' whether in chapel or church, tent or the open air, through public preaching, private appeal, the distribution of Christian literature, and through both paid and voluntary workers.

“Endeavoring to raise to a higher level all phases of church life, Sunday School and Bible Class, through systematic giving, public appeal, and personal work

“Endeavoring to reach all classes of society including retired and active officials, members of the provincial legislature, the old time scholar class, the new student class, police, soldiers, factory employees, burden bearers, jinriksha coolies, patients in hospitals, inmates of prisons, refugees, and the ‘down and out’,

“The attacking in a Christian way of great evils that oppress, pauperize and degrade the people, such as opium, drink, gambling, social vice, graft in public office, dishonesty in private dealings, superstition, belief in lucky days, cruelty to animals, etc., and co-operating with high-minded Chinese in measures for the uplift and betterment of the people The aim is NANKING FOR CHRIST. The method united prayer and effort.”

Dr. Price is assisted by a foreign office secretary, and two Chinese secretaries, one for evangelistic and the other for literary work.

Practically every Christian agency in Nanking is represented in the Church Council. The distribution of Christian literature is vigorously pushed. The Nanking Church Council Monthly, sent to all Christian workers in the city, gives information which makes it possible for all to think in terms of the entire city. The Nanking Bulletin of Church and Community, issued weekly, giving local notices and items of interest, is distributed to the whole English speaking community. Its aim is to create community interest centering in Nanking union church.

The primary purpose of the Nanking Church Council is the promotion of co-operation and understanding between the Christian workers of different denominations. The long list of united activities described by Dr. Price includes evangelistic campaigns, famine relief work, Sunday School Unions and Vacation Bible School work. Under the able leadership of Mr. S. T. Wen, commissioner of foreign affairs, a union social service committee has opened a small Peoples' Park, in which there is a rest house for jinricksha men, a public well, playgrounds for children, and a model house for a ricksha puller. The

plans of the committee include the establishment of a model settlement in which ricksha pullers and their families may have small, but clean and neat houses, the initial cost to be not over \$100, Mex.

A description of the work of the Hangechow Union Committee which for years has been under the leadership of Dr. Robert Fitch would fill more space than we are allowed. During the last year the principal emphasis has been on evangelism and the distribution of thousands of tracts. Seven new tracts were published. A new Sunday School hymnal is being prepared. An impressive Easter Song Service as well as a Sunday School children's party, and various union prayer meetings, festivals and song services, were conducted by the festivities committee of the Union. A full time nurse has been employed to conduct clinics in schools. A discussion group on social problems to train social service workers led by Professor D. H. Kulp, II, of the Shanghai College has been particularly valuable. Fifty-eight students were enrolled, coming from Huchow, Shaoshing, and Kinhua, as well as from the city of Shanghai.

This committee participated in the movement against lotteries in the city and was partially responsible for their being closed last year (1923).

A similar federation is well established in the Wu-Han district, all missions co-operating. Its emphasis also has been placed on evangelistic work and social service. In several cities such as Kaifeng and Moukden there are the beginnings of an inter-church organization without fully organized union. In Moukden, we are told, "Everyone works together, but we do not bother with any large organization." The principal union effort expresses itself in the Week of Evangelism and certain projected pieces of social service for ricksha coolies.

In Kaifeng there is a union of four churches known as the Ssu Kung Chiao Hui Lien He Hui which is now pushing a union program. In Nanch'ang, Soochow and Tsinanfu they report that they are not formally organized, although frequently there are union evangelistic campaigns and union weeks of evangelism.

The Tientsin federation, four years ago one of the most prosperous in China, by which all the churches and the Y. M. C. A. and Y. W. C. A. were endeavoring to work out a comprehensive plan for the whole city, including evangelism, mass education, social service and religious education, has made no progress recently. A foremost evangelistic worker in the city describes its condition as follows:

“The Tientsin Christian Union has been organized for several years, — just how long I do not know. It was re-organized five years ago and was on the road to doing some good work. A couple of years ago it was over-organized and since has lain semi-dormant. I think the greatest trouble with us now is that there is no one who has the time to follow the thing through and put in some real time on the job.

“The Union is representative. Each church whether large or small appoints five representatives to the central committee which is supposed to meet three times a year. This committee appoints an executive which is supposed to ‘carry on’ and report back to the central committee. As for this last year there is very little to show in the way of work done. The machinery is here but the throttle is ‘busted’!”

In Peking after the China-For-Christ Conference a very progressive plan was worked out by the church delegates who attended the gathering. A large council of one hundred people, representing both churches and missions was to meet quarterly, while a small executive body of fifteen, elected by this larger group, was to work out the program for the city. Retreats were held and apparently things were going well. Lack of leadership, possibly over-organization, and the long distance necessary for persons to travel in order to attend committee meetings brought this federation to a condition of inactivity. In its place a less pretentious movement, a union of the representatives of individual churches without denomination or mission representatives, as such, has grown up. Some of the young leaders of the city are active in the movement and it is gradually attaining a place of importance.

What are the factors in the success of the movement? One is responsible leadership. Nowhere is such a movement accomplishing results unless at least one competent secretary is giving his full time to it. Federations run by committees alone do not succeed in doing much work. Another is the relationship between the churches and the Y. M. C. A. and Y. W. C. A. These organizations already view the city as a unit. Only by the closest coöperation and preferably by the organic union of the program of the Associations and the Church can the best results be attained. An illustration of such successful coöperation is the Student Work Union in Peking.

Another lesson from a study of these federations is the inadvisability of over-organization. Complicated machinery is not what the leaders of the Chinese church desire. Unpretentious schemes are most likely to find favor.

The facts of this article are certainly not comprehensive. It has been impossible to get reports from many large cities, but few as they are they indicate that without close coöperation many valuable Christian undertakings now projected in China will be impossible.

CHAPTER XXVII

DAILY VACATION BIBLE SCHOOL

S. P. Chüan

The D. V. B. S. has again had a successful year. Work was carried on in fifteen provinces. 1171 Schools were conducted by 4,744 teachers in the various centers, in which 51,354 children were taught to read the Bible, and to follow the good example of the little ones whom they discovered through their reading of the Bible stories.

The National Report of the D. V. B. S. for 1923 is in process of publication. Material has been collected from many centers where experienced teachers are found, and work begun on the publication of a Chinese Bible Story Book. The hope is that by the summer of 1924 the D. V. B. S. teachers will have in this new book a guide as to how to tell Bible stories. Two other text books are also in the course of preparation. It was hoped that all these new publications would be ready for use in 1924. In the early spring of 1924 the D. V. B. S. Department was busy with the preparation of these new pieces of literature.

The detailed report of the 15 provinces is as follows:

	<i>Provinces</i>	<i>Schools</i>	<i>Teachers</i>	<i>Students</i>
1.	Fukien	138	487	5262
2.	Szechwan	24	81	1618
3.	Anhwei	20	116	862
4.	Honan	1	16	100
5.	Chekiang	66	298	4151
6.	Fengtien	16	50	544
7.	Hupeh	31	260	2321
8.	Kiangsi	13	17	330
9.	Hunan	35	139	2427

10.	Chihli	22	89	1395
11.	Kwangtung	65	479	5296
12.	Shantung	520	1553	12345
13.	Kiangsu	217	1138	14408
14.	Shansi	2	15	199
15.	Yunnan	1	6	96
	Total numbers	1171	4744	51354

CHAPTER XXVIII

CHINA SUNDAY SCHOOL UNION

1923-4

E. G. Tewksbury

Personnel

The salaried staff of the China Sunday School Union consists of the General Secretary and his Associate Chinese Secretary, the Rev. E. G. Tewksbury and Prof. T. F. Pan. Through the courtesy of the China Inland Mission, the Rev. Joshua Vale gives a large amount of help as Editorial Secretary, and by arrangement with the Northern Methodist Mission, the Honorary Treasurer, Rev. W. H. Lacy, D.D., who is also Secretary to the Finance Committee of the Methodist Missions in China, is able to devote a portion of his time to the business and financial departments of the Sunday School Union. There are two bookkeepers and two men in the mailing department. Stenographic assistance is available, when needed.

Finances

The China Sunday School Union receives a grant from the World's Sunday School Association of \$5,000 gold annually. The same amount has been granted by the Stewart Evangelistic Fund for the last few years. In addition to these grants the sale of Sunday School Lessons and Religious Education material brings in approximately \$7,000 gold annually, which enables the Union to meet its printing expenses, postage and bookkeeping expense.

Governing Board

The General Committee of the China Sunday School Union has grown up around the Sunday School Committee which was appointed at the Centenary Conference. It consists of thirty-five members, twenty of whom may be elected by the several missions having the largest amount of Sunday School work. The Executive Committee of the China Sunday School Union consists of those members living in or near

Shanghai. Of these three are members of the original Sunday School Committee, eight are elected by the Northern Methodists, Southern Methodists, Northern Presbyterians, Southern Presbyterians, China Inland Mission and London Missionary Society, six are members of the salaried or honorary staff of the China Sunday School Union. Eight members of the Executive Council are Chinese. Two of these are secretaries of the National Christian Council. There are also Corresponding Members in Peking, Hankow, Kaifeng, Moukden, and other places. Arrangements are being made by which the China Sunday School Union can be affiliated with the National Christian Council, certain members of the Committee of the China Sunday School Union being directly appointed by the National Christian Council, and the China Sunday School Union having direct representation upon the National Christian Council.

Literature

From its beginning in 1910, one of the tasks definitely assigned to it by the Centenary Conference was the preparation of Sunday School Lesson Helps and Teacher Training literature. For a long period the China Sunday School Union has been the only agency in China issuing Sunday School Lesson Helps. For several years, however, the work of the American Baptist Missions has been carried on separately from the federated work of the other missions. They have several Sunday School experts at work upon Sunday School Lesson Helps and literature, and are issuing a Graded Series of Lesson Helps based upon the International Uniform Lessons.

The China Sunday School Union issues sixteen varieties of Helps for the International (American) Improved *Uniform* Lessons, and five different Pupil's Helps for the International *Graded* Lesson courses. The circulation of the C.S.S.U. Lesson Helps is approximately 180,000 each Sabbath. They contain annually more than 20,000,000 pages of material. They are sent out from the C.S.S.U. office quarterly by mail to some 2,000 different Sunday Schools.

The impossibility of circulating publications of high cost has made it necessary for the C.S.S.U. to print its material on paper of a very cheap grade. The prices per

year, postpaid, of the various issues vary from one cent to eleven cents gold. But, even with literature as inexpensive as this, the Mission Boards of missionaries themselves are still obliged to partly subsidise its purchase, in the Chinese Sunday Schools. Moreover, the prices charged by the C. S. S. U. merely cover the printing, mailing and bookkeeping costs, the expense of the editorial work being met from Home organizations.

As regards Teacher Training literature, there are now available in Chinese from different publishers and mostly with English translation or original, some twenty Teacher Training books and fully as many smaller booklets and leaflets. A Teacher Training certificate with detachable seals is given by the C. S. S. U. to teachers who are studying Teacher Training books or attending Institutes.

Indigenous Literature Emphasis is being given to the preparation of Lesson Helps and other material by the Chinese leaders themselves. At present the International *Uniform* Lesson Helps are largely prepared by the Associate Chinese Secretary. He is entirely free to use for his lesson preparation material in English which he adapts, or to prepare original material.

The illustrative material on the Lesson Helps has for a long time contained problems and Chinese style problem pictures, which aim to coördinate everyday life with the Biblical material. Several hundred such problems and pictures, illustrating behaviour situations in Chinese life, are now available. It is expected that these will be grouped and issued in a series of lessons, based not on the historical or biographical sequences of the Bible story, but arranged according to the life situations under which the pupil's life is lived. Formerly but two life problems have been offered for each lesson — one for children, and one for adults. At the present time, however, we are able to offer a half-dozen or more in connection with each Bible lesson. The Training Class is, therefore, able in its lesson preparation to select from these life situations those especially fitted for the pupils.

The excellent work in color photography and printing, and the kindness of the home publishers, has made it possible for Bible Lesson Picture cards to be printed in

China. 50,000 sets of these are now required by our constituency, and we are able to send them postpaid to all parts of China at approximately 12 cents gold per set per year. Having thus in our own hands the selection and preparation of the illustrated material, we can select not only such pictures as accurately portray Palestinian conditions, but also adapt locally any pictures that may have in them elements appropriate to Chinese conditions. We have also been able to prepare Chinese style colored paintings for illustrating Bible scenes, such as those depicted in the Parables of Jesus, etc., using in these Chinese figures and scenery.

Teacher Training Institutes Few things are more needed in China than the training of teachers. And this applies not only to Religious but also to General Education. The holding of Teacher Training Institutes has always been a large factor in the work of the C. S. S. U. Of late years, however, the increasing demands of the Literature Department and the calls for help in giving courses on Sunday School and Bible Teaching Methods at general Conferences have made it practically impossible to hold special Institutes for training Bible Teachers.

Statistics There are no later statistics on Sunday School work than were prepared for the National Christian Conference and the China Survey. The figures for the statistical year 1920, were as follows:—

Number of Sunday Schools.....	5,698
,, ,, S. S. Teachers	12,291
,, ,, S. S. Scholars.....	259,261

It must be noted, however, that the definition of "Sunday School" is "any group of people, adults or children, (1) definitely organized to meet once a week for Bible Study, (2) having a class system and (3) following regular courses of study." It is practically impossible to find a connotation for the term "Sunday School" which will be satisfactory to all denominations and nationalities and will give adequate statistics of the work which is being done by all the nationalities and churches as regards the teaching of the Bible. It is, of course, to be understood that all converts and children that are connected in anyway

with the church centers are instructed in the Bible, this being an integral part of the work of a Christian Church. In addition to the work for the church constituency, there is being conducted in almost every center a work for non-Christian children which may take the form of a general children's service, and thus not be reported as a children's Sunday School. There were also enrolled in 1923 some 50,000, mostly non-Christian, children in the Daily Vacation Bible Schools. Adding to these the classes of adults which Sunday by Sunday, in so-called Station and Bible Classes, are studying the Bible, the grand total for those under instruction would of course greatly exceed the Church membership, and likely approach that of the so-called "Total Christian Constituency, 700,000."

CHAPTER XXIX

CHINA CHRISTIAN ENDEAVOR UNION

E. E. Strother

Christian Endeavor has gone on steadily during the year 1923.

Literature The increasing circulation of Christian Endeavor literature is one of the best indications of the vitality of the C. E. Movement in China, and it is probable that quite a number of new C. E. societies have been organized which have not yet been reported, as it has been found that frequently societies are started in inland places through the use of the C. E. literature, that fail to send in any reports. The books are also used in hundreds of group meetings, in which the members take part according to the C. E. plan, although they are not formally organized with officers and committees. The total circulation of C. E. Topic Books and Topic Sheets during 1923 was larger than during any previous year, being 105,000 copies, made up as follows: Topic Sheets, 50,000, Chinese Topic Books, 50,600 and English Topic Books 5,000 copies.

Societies Report cards have been received from more than a thousand C. E. societies, including some scores of new societies, and it is probable that there are several hundred more societies that we have not yet heard from, owing to the conditions of stress and strain under which the missionaries and Chinese Christians are living in the midst of brigands and robbers and lawless soldiers. A few places have reported that because of the looting of their cities and the terrorizing of the people of whole districts for many months, the C. E. societies had been temporarily discontinued, but in most cases the little groups of Chinese Endeavorers have continued to meet regularly. Considering the reports received and the circulation of the C. E. literature, it is estimated that

there are probably more than 1200 C. E. societies and a membership of 50,000 or more, throughout all the provinces of China.

The following are a few typical extracts from reports regarding the helpfulness of C. E. methods in different districts:—

“C. E. is becoming an ever-increasing asset to the church. It strengthens the individual Christian life, stimulates evangelism, and trains workers for Christ. We have in our field 48 C. E. societies, with 454 men and 256 women. We also have 8 Junior C. E. societies, 70 boys and 42 girls.”

“C. E. books are used in our seventy-two weekly meeting places. We see a great improvement spiritually in our young people since organizing the C. E. societies in our boys' and girls' school. The C. E. books are a great help and the young people are becoming more free in taking part in meetings.”

“Our C. E. is only one year old; but it is doing good work; there is much to be encouraged about in it.”

“We have two good C. E. societies here in the city, and some eight or nine smaller ones in our country districts, all using the C. E. literature.”

CHAPTER XXX

THE EPWORTH LEAGUE

Geraldine Townsend

Birthplace The Epworth League of the Methodist Episcopal Church received its name from the birthplace of John Wesley, — Epworth, England; and from a noted statement by this founder of Methodism: "I want a *league*,—offensive and defensive, with every soldier of Jesus Christ enrolled in it." The Epworth League may well be defined as the young people of the Methodist Church the world around at work. It is organized at present in thirty-one different countries. Only within the last few years has any attempt been made to unify the work of these various countries by placing trained secretaries in charge. The interest of the young people of America in this new enterprise goes hand in hand with a new interest on their part in the study of Kingdom Geography, and is expressed in their slogan of "Young people's work for young people!"

Between September, 1890 and October, 1902, twenty-five chapters of the Epworth League in China were officially recognized and granted charters by the Central Office of the Epworth League in Chicago. No doubt there were other Epworth Leagues in the Methodist churches of China, but only these were officially recorded prior to the opening of the China Office of the Epworth League in Shanghai in 1920.

Nanking According to the Chicago record, Nanking may boast the oldest Epworth League in China. This Epworth League in the Methodist Girls' School, one of four chapters to-day in Nanking, is still one of the strongest and most spiritual in all China. Originally, with no constitution to follow, their activities consisted merely of a testimony service on Sunday, an Anti-Narcotic meeting once a month, and a literary

program once a term. In 1897 a complete cabinet was elected. The four vice-presidents then planned work for their departments, the literary meetings were held oftener, each month a business meeting was held with reports of the work presented, and during vacations the students went home to tell their neighbors about the Christ they had come to know. Since the Epworth League Office has been established in Shanghai and helps have been provided in the Chinese language, this Epworth League has aligned itself with the centralized program, is working in accordance with the constitution, is using the lessons written for China, Malaysia and Netherland Indies, and is trying earnestly to become a standard chapter. They have one hundred eighty-four active members and sixty associate members. They are seeking to make good their purpose as expressed in the Epworth League motto: to "Look Up" to God and to "Lift Up" their fellow-men.

Hinghwa The Hinghwa Epworth League is officially the second, and Foochow Epworth League the third in age in China. The chapter in Asbury Church, Peking, is not only one of the oldest in China, but also has the distinction of originating the Chinese name for the organization.

Working without any helps in Chinese, without a constitution or lesson-book, or guide of any kind, the Epworth Leagues in China naturally became stereotyped in organization and stilted in expression. A hymn-prayer-sermon type of meeting was held on Sunday, a collection was taken and the money used to help a few poor people, but that was frequently the extent of their activities. This was especially true in South China where small country churches with no genuine constituency of young people had their Epworth League. Unfortunately, there it came to take the place of the Sunday evening service by the pastor; it was not truly a *young people's* meeting; and all the church members were reported as members of the Epworth League.

Headquarters The plan for an Epworth League Office in Shanghai and the appointment of an Epworth League Secretary to give full time to young people's work was part of the vision the late Bishop Lewis had for

Methodist youth in China. In 1919 Bishop Lewis asked Dr. Guthrie of Chicago, the General Secretary of the Epworth League, for an appropriation of \$ 10,000 to make possible four Chinese field secretaries, and a missionary to open up the work. After considerable interest in the plan developed, the Board of Epworth Leagues in America appointed Paul Hutchinson of Shanghai as Secretary of the Epworth League for China, appointed the writer as Associate Secretary and made provision for the appointment of an Advisory Council by the East Asia Central Conference. My own State of Michigan, stirred by the challenge of helping the Methodist young people of an entire country, volunteered to raise the budget, and make it their annual responsibility.

Literature Not all has been accomplished yet that we desire to see accomplished, but a foundation has been laid. Literature has been provided for the most pressing needs; personal contacts have been established with the local chapters; more uniformity of organization has been secured; and some of the chapters at least have been inspired to greater activity in service and their spiritual life deepened. We have worked without the full budget; Mr. Hutchinson's appointment to Centenary work left me with the entire responsibility; the four Chinese secretaries have not been found nor could they have been financed. We are asking for, and seeking now, at least one Chinese secretary; for the work, like any other in China that is to make progress, must have Chinese leadership.

Place and Work Out of the four short years I have had in the work since my year of language study, I have come to regard the place and the work of the Epworth League in China as follows: (1) among the children of our church to develop them in spiritual things and to train them for future church membership; (2) among the young people of our Methodist schools, — to solve the problem of bringing young men and young women together in a Christian atmosphere for normal, social fellowship; (3) among the young people who have come up through our Methodist schools, who are no longer held by any *student*

organization — whether it be the Association or the Epworth League — but who must be reached by a *church* young people's society and definitely tied up to its work until they take their place as mature church members.

The Church in China, of any denomination, needs to be doing certain things for its young people. It needs to transform their mental assent to a doctrine to a *personal allegiance* to Jesus Christ. It needs to break up the tendency toward exhorting about Christianity instead of living it out in every-day life. It needs to solve the problem, which non-Christian forces are making imperative, of bringing about normal, Christianized, social fellowship between the sexes. It needs to direct to Christian life-service of all kinds through summer institutes and training conferences as the Student Volunteer Movement is doing for one phase of Christian service. Any organization of young people working on such a program as this has a place in China. The name under which it works matters little.

CHAPTER XXXI

THE CHRISTIAN PUBLISHERS' ASSOCIATION

J. Whitsed Dovey

Membership and Object

The Christian Publishers' Association now includes twenty-one organizations covering practically all the agencies engaged in the production, printing and distribution of Christian literature in China. The object of the Association is to secure the coöperation of these agencies in a united and progressive policy. For some time past special attention has been given to the problem of distribution and vigorous efforts are being made to develop plans of mutual advantage to the missionary and Chinese leaders as well as to the societies concerned.

Last year the Association was recognized by the National Conference and National Christian Council as a national organization and entitled to representation as such at the National Conference.

The China Bookman

A quarterly periodical entitled "The China Bookman" is published through the coöperation of members of the Association and is sent free to four thousand missionary homes in China and to over two thousand Chinese Christian leaders. In addition to announcements of new and current publications in English and Chinese, "The China Bookman" includes reviews and articles on problems connected with the work of literature in general. It has proved a most useful advertising medium for the agencies concerned.

Coöperation

In pursuance of the object of the Association to promote effective measures of coöperation between the different agencies to their own advantage and also to the advantage of the missionary and Chinese constituency, efforts are continually being made to improve the arrangements whereby one organization may handle

or at least receive orders for publications of other societies in order that buyers may be enabled to deal with one body only. The question of satisfactory discounts is also continually receiving attention.

Field Agents For some time past there has been a growing conviction that a system of field agents is essential in order to promote the more effective distribution of the wealth of Christian literature produced by the various publishing agencies and that there is a call for missionaries to be set aside for a time to organize the distribution in the same way that workers are set aside to prepare the literature. In order to give effect to these desires the Association has made repeated efforts to secure the appointment of such workers, particularly in West China and East China as a commencement, and is hopeful that such field agents will be set aside by their missions for this work in the very near future.

Literature Stewards In order to increase the effective use of literature in connection with the ordinary work of mission stations, several missions have adopted a proposal made by the Association that Literature Stewards should be appointed by the various stations of the mission, who should be responsible for keeping in touch with the publishing agencies and thus ensure that all new publications are immediately known to the local workers. As a rule two stewards have been appointed for each station,—one for women's and children's literature, and one for general literature. It is hoped that there may be a wide extension of this plan in the near future as it involves no obligation on the part of the stations.

Classified Index The Classified Index of Chinese Christian Literature prepared by Rev. G. A. Clayton some five years ago in coöperation with the various publishing houses is now in course of revision and it is hoped to publish a new edition early in the new year.

Industrial Conditions At the annual meeting of the Association held in May, 1923, the Association put itself on record as endorsing the resolutions on industrial conditions adopted by the National Conference, laying down the following standards:

- (a) No employment of children under 12 full years of age.
- (b) One day's rest in seven.
- (c) The safeguarding of the health of workers (i.e. limiting working hours, improvement of sanitary conditions, installation of safety devices, etc.)

The Association requested all its members to confirm their own adherence to these standards in the case of those organizations possessing printing plants of their own, and also that in the case of printing work entrusted to outside presses preference be given to houses adhering to these standards. Many of the members of the Association have already replied confirming their adherence to these conditions.

Mission Presses For some time past questions have been raised as to the status and future usefulness of mission presses in view of the growth of commercial printing houses. At the request of the China Christian Literature Council the Association is coöperating in an investigation of the present and future usefulness of these mission presses which have done so much for the cause of Christian literature in the past, and it is already clear that whatever work now undertaken by mission presses might be handled by commercial printing houses, there is a wide field of service for the mission body which these agencies and no other at the present time can undertake.

PART V
SPECIAL EVANGELISTIC MOVEMENTS
CHAPTER XXXII

SOME PROBLEMS OF EVANGELISTIC WORK

1. IN THE CHURCH

Although the church has worked in China almost one hundred and twenty years, its communicants are still less than four hundred thousand in number. While we may say that it is men who sow the seed but God who makes the seed grow, yet we cannot be absolved from the responsibility for such insignificant results by saying that this number of communicants is just what it should be. Let us single out some of the difficulties.

Lack of Leaders The first difficulty is in the men and not in the insufficiency of money. We frequently hear the cry in the church, "We need money and leaders." Some people think that finance is more important than men. They assume that when there is money there will naturally be men. Some members of the church think that because of the small salaries the church offers, promising leaders have to leave the church for other forms of service. The money they might receive from the church is not sufficient to cover necessary expenses of living. This argument, though seemingly reasonable, cannot bear careful scrutiny. Should we decide upon the work of a minister in accordance with the amount of money he receives or upon some other and better basis? Christ said: "Be not anxious for the morrow; sufficient unto the day is the evil thereof." Again he said: "All these things will be added unto you." From this it may be clearly seen that whosoever is sent by the Lord will not suffer for lack of sustenance. The Lord will provide all things for him. Moreover, if one is

really sent by the Lord, he will never be anxious over money. Look at the great work of Isaiah and the other prophets, at St. Paul of the New Testament and the other holy apostles and note how great their work was. Who of them was oppressed by lack of means to sustain his life? Who of them failed or left the work of preaching on account of money? At present we have men like Mr. K. C. King of Kansu; Dr. K. T. Chow who studied and graduated from four large universities in the United States and who is now preaching at Kutien, Fukien, for thirty dollars a month only; Messrs. Hsieh Meng Tsuh and John Li who have travelled far and wide; we also have such women in the church as the Misses Miao Ying Tseng, Miao An Sing, Wong Be Tseng, and Sa Ju Yu who have done evangelistic work in Changchow, Kiangsu: according to reports of work their labor has yielded fine results. It is a sad thing that such people are so few-rare as the feathers of the phoenix and the horn of the unicorn!

The Unentered Door The second difficulty is found within and not without the church. Over twenty years ago an aged American missionary was asked by his fellow countrymen in America whether the doors of China were open to the preaching of the Gospel or not. His answer was that not only are the doors open but that both the doors and walls had been broken down and the whole country is ready to receive the good tidings. Present day China verifies his statement. The Christian vessel has a favourable wind. A certain minister was heard to say that he had met but one person in six years who opposed the truth and even he did not oppose it strenuously. Recently the Presbyterian church sent five or six preachers to preach in Tingyuanhsien, Anhwei. They were gladly received by people in every walk of life. The word of the Lord was certainly fulfilled: "the field is white unto harvest". But how many in the church have shown the courage of going forth for the Lord to reap the harvest which is ready? According to my personal observation in many places, the majority of church members are fast asleep. They have become lukewarm like those in the church at Laodicea! In spite of the fact that personal evangelism, preaching in families, new year evangelistic

meetings, and big evangelistic campaigns have been promoted and emphasized, the four hundred thousand communicants still remain unmoved in the face of this call to go forth to save those who have not had the opportunity to return to the Lord. When the Day of Judgement comes, will not the people of this generation who have not been given a chance to receive the Lord into their lives, rise up in judgement against the believers in the church?

Loss of "First Love" The third difficulty is found in the old believers, not in the young believers of the church. When I use the term "old" and "young" I do not refer to age. I mean the length of years during which one has been a Christian. According to the opinion of many, new Christians who have just joined the church are more enthusiastic and more willing to serve, than old Christians who have been in the church longer. Those who take pride in their being old church members, thinking that they have an older root of the doctrine in them, not only do not make progress themselves, but at times even prevent others from doing what they ought to have done themselves. How can the church grow if these people merely grow in years and not in the stature of Christ, thereby being unable to bear fruit? If all the members of the Church could return to their first love and hasten to work for the church in saving men, the progress of the church would be very surprising.

Lack of Power The fourth difficulty is that the true work of the church is in receiving and not in giving or preaching. The Lord said to his apostles that when the Holy Spirit would come upon them, they would receive power and bear witness for him from Jerusalem even unto the ends of the earth. Now within the church in China there are about thirty thousand people, both foreign and native, who hold some sort of office or other. Among them about two thousand people are ordained by church authorities. Are they like the Apostles on the day of Pentecost, filled with the Holy Spirit and power? If they really had this power they could have the same surprising results. The trouble is that the leaders of

the church now emphasize reason, methods, and forms, forgetting the inner chamber and the secret communion of themselves with the Lord. When they themselves have departed from the source of the living water, how can they help to extend the church?

TING LI MEI

2. OF ITINERATION

**Magnitude
of Need**

It may be safe to say, that the number still unevangelized in China is equal to all who dwelt upon the earth when our Lord gave the command to evangelize the nations. It is a gigantic task to so present the Lord Jesus Christ to them, that they can intelligently accept or reject Him. Let any one go over the provinces and it is easy to see that the need for evangelism is overwhelming. Even where missions have been established for years whole cities and countless villages seem practically untouched. Though our mission (P. C. C.) has been working in North Honan for over thirty years, yet two weeks ago we visited a country of over nine hundred villages, and could not find a Christian in two dozen of them. There are other countries in North Honan where the unevangelized conditions are equally bad. The recent mission survey laid bare conditions even more startling.

**Doors Wide
Open**

The very accessibility of the Chinese people makes our problem all the more urgent. It would be hard to find any people on earth more open to the Gospel. This is true of scholars as well as of the humblest people. During over thirty-five years in China I have tried to present the claims of Christ to scholars of every grade, and have found them perfect gentlemen. Of late, we have found the scholars more approachable than ever; the common people also hear the Word gladly. There is no need to pray for open doors in China for they are wide open already.

Pressing Need

The pressing need is that the Church of God get into close contact with this great unevangelized multitude. The evangelistic note must ring out more insistently from all hospitals, schools and literature agencies. Every local church and every

Christian should be the radiating centre for the life of Jesus. Aggressive evangelistic campaigns should be carried out by every mission. Two years ago the leaders of the Changteh field asked my wife and myself, to go with an evangelistic band for five months among the out-stations; one of the results was three thousand names given in as enquirers. Again, this year, we are going among the churches with the permanent evangelistic band, and we take along a tent that will seat five hundred. But the Changteh field is large enough to have a dozen bands like this going all the time.

The Spiritual Need Mr. Moody used to say that it was better to get one hundred people to work than to do the work of one hundred. There are enough Christians in the land, Chinese and foreign, to evangelize all China in this generation. All that is needed, is that each one be endued with power from on high as at Pentecost. It is cheering to find among leaders that the emphasis is coming more and more to be laid upon the spiritual. The secret of evangelizing China lies in a mighty outpouring of the Holy Spirit upon those who know the Lord. We asked an elder recently how conditions were in his congregation, and he replied that things would look up if the old church members would only live right. At another place the non-Christians said, "Your Christians here give way to bad temper, pride and quarrels the same as the rest of us." At still another place, a woman said "There is little hope of the cause of Christ flourishing in our congregation, until the old church members die off." Alas! this is only too true of thousands of churches over the land, and it can be said of them as of Sardis, "Thou hast a name, that thou livest, and art dead." A few years ago, at Peitaiho, a prominent Chinese leader said, "Last year 26,000 adult converts were baptized into the church of Christ in China, and the paid workers Chinese and foreign were 27,641 — not one convert per worker to say nothing of the tens of thousands of Church members". Surely, the vital need for the evangelization of China is that all her church members be mightily quickened by the Spirit of God.

3. IN RURAL FIELDS

The purpose of this article is to select some of the more outstanding problems of country evangelistic work in order to stimulate further thought and experimentation rather than to give any final solutions. Lack of space prevents the incorporation of many helpful suggestions from workers in various missions. Those who wish to pursue the subject further should consult "The International Review of Missions", Vol. XII, pp. 557-579, and S. J. W. Clark's memorandum on "The Country Church and Indigenous Christianity" (published by the National Christian Council).

Salaried Chinese Workers What should be the grade of training given to our Chinese colleagues? Since country congregations cannot pay large salaries, should it be comparatively simple, or, as many maintain, should it be as high as possible? In the latter case, what work is best adapted to the older and less highly trained workers?

How can we make the training of such workers thoroughly practical? Is homiletics, for example, as important as religious education? It seems highly desirable that students have clinical experience during the course in varied forms of practical Christian service and particularly in soul winning and that the instructor who superintends this work should also supervise their practice work during vacations. At least one school gives the long vacation in the winter months which are best adapted for vigorous evangelistic work.

When the preliminary training of such workers is completed, how may they continue to grow both intellectually and spiritually? How may they be raised so far above mere professionalism and so filled with evangelistic ardor that isolation, privations, and hardships can never quench their passion for souls? Conferences, retreats, frequent personal letters from the evangelist in charge, the granting of complete initiative in their work—all these can be made exceedingly helpful in furthering such aims; yet burning zeal can be kindled only from hearts that are themselves aflame.

A still more fundamental problem of policy concerns the status of such salaried workers. Shall they stand in a pastoral relation to definite Christian communities, or, in view of the vast work still to be accomplished, shall they be regarded as evangelists-at-large, the various scattered congregations being served by local unsalaried workers?

**Volunteer
Chinese
Workers** What shall be the method of selection of those who will prove real local leaders? Shall they be trained at outstations chiefly under the direction of Chinese evangelists, or, as in the Nevius plan, at the central station directly under the guidance of the foreign missionary? In any case it would seem best that their style of living should be simple and that they should not lose touch with their country environment. Whatever is taught them, practice should accompany teaching, great emphasis should be laid upon teaching and winning others, and the approved form of phonetic script made a ready tool in their hands. It would also seem wise to give instruction in the duties of church officers and finance committees.

As to the functions of such workers, it would seem that they should shoulder the responsibility for the conduct of the simple services at their center and also for spiritual welfare of the believers in their group, thus freeing the missionary and salaried evangelists for more aggressive work in unevangelized sections or for intensive evangelistic campaigns among the churches.

**Christian
Community** What should be the test of admission to the church? Most would agree to stress character rather than the mere knowledge of a creed. But how obtain accurate information as to the applicant's real character? Other good tests which have been tried are that of literacy, which cannot, of course, be pushed to the limit, and that of winning others, which has proved so useful in Korea.

How can the growth of the church be promoted? This question divides into several others. How may Bible study be fostered? Phonetic script has been a wonderful boon here. How may the personal prayer life be developed? Would not a weekly cycle of local and world-wide topics for prayer be a help in widening the spiritual horizon?

What will lead the Christian community to see the need of keeping the whole Lord's Day, if spiritual life is to be conserved; discipline, or a constructive program of Christian activities? How may Christian parents be persuaded that the building of the family altar is an indispensable part of Christian nurture? How may Christian stewardship be so thoroughly inculcated that the church will naturally become self-supporting? Here example is even better than precept. Lastly, how may the church be so filled with enthusiasm for saving men that witness-bearing will become spontaneous and the evangelizing of entire districts be begun in earnest? Mapping the field, assigning definite responsibilities to certain groups and individuals, establishing a friendly rivalry between groups — all these have their place and are very helpful; but they do not entirely solve the problem.

General Community How may outsiders best be reached? Is there a prejudice in their minds against salaried workers? It has been found a help in some places for these workers to be introduced by Christians to their relatives, friends, and neighbors.

What is the best present-day method of reaching the masses? Tent campaigns of intensive evangelism are reported from various quarters and seem to have proved remarkably effective in quickening Christians and in winning outsiders.

Has not the time come when both evangelists and Christians should take more interest in the physical and moral welfare of the general community? This is an illustration of Christian citizenship and may be the means of enlisting the co-operation and friendship of thinking men.

After all, it is not by organization, nor by methods, but by God's Spirit that this work is to be accomplished, these problems solved. He alone can purge the church of unworthy motives, fill it with love and joy, and send it out to win the world.

Wm. A. MATHER.

CHAPTER XXXIII

THE WORK OF THE UNITED METHODIST

MISSION IN WENCHOW

Wm. R. Stobie

Historical and
Numerical

The writer's association with this work dates from the end of 1896. The mission was started in 1877 when the first missionary was sent out from England to work in this district, Rev. Robert Exleye, who died after about four years' residence. Soon after came Rev. W. E. Soothill, the present professor of Chinese at Oxford, who, shortly joined by his wife, worked and lived in the prefecture for some 25 years and for a considerable period of it having no other foreign worker with him, so that the "mission" may be not unfittingly regarded as a monument to his devotion, wisdom, statesmanship, and constancy. In the early nineties Rev. J. W. Heywood came fresh from College to join Mr. Soothill, but in 1896 he was transferred to Ningpo to superintend the mission there. The medical work was then in its infancy, the first medical missionary, Dr. A. Hogg, who retired in 1901, having begun it about three years earlier. In 1896 the educational work of the mission consisted of a total of 7 day and Sunday schools with 12 teachers. These day schools were the then usual small village institutions with the old-fashioned and sometimes ancient dominie not always possessed of much more than a nodding acquaintance with some of the classics. Twenty-six years ago, besides Mr. Soothill, Dr. Hogg and the writer, then a new-comer with one year's experience of ministerial work in the home churches, there was a staff of two itinerant Chinese preachers, 57 local preachers (17 of whom were paid) 744 church members, (600 on trial) 14 junior church members, an increase of 109 in the year, 6 chapels, 74 other preaching places which were either temples, or rooms of private houses freely lent by

the tenant or owner or in some cases granted on a small annual rental, 7 schools, 116 pupils and 12 teachers. At the end of 1922 there were 6 missionaries: one, a new arrival — the first foreign nurse to be sent out —; one in England having broken down three years before; one, the college principal on furlough; and one, the superintendent of the mission also in England, having broken down under the strain in the preceding September. There were 74 chapels, 196 other preaching places — the majority of the latter lent, or rented mostly for the small annual sum of a few dollars, 32 Chinese ministers, 3 evangelists, 278 local preachers, 3,613 members, (3,012 on trial) 2110 Juniors, (under 16 years of age) 5,272 enquirers, 7 elementary schools with 149 pupils and 7 teachers, 4 primary schools with 20 teachers and 275 pupils, one college with 14 teachers and 188 pupils and one girls' school with 6 teachers and 49 pupils. As one of the missionaries was a medical and another an educational missionary this meant that for four years 270 and more churches had to be superintended by two foreign missionaries; there never has been more than three.

It is expedient to bear in mind the preceding figures to appreciate more correctly what will be said later of the character and weaknesses of the work, also to visualize the extent and topography of the district. From north to south the area worked, i.e. with churches planted and resident pastors, is 150 English miles or more and from East to West about 110. Wenchow city, 21 miles up the river on its south bank from which the whole area is worked and where the missionaries reside, is very nearly central as it stands at the outlet to almost the whole district. Except for a very narrow strip bordering the long coast-line which widens somewhat in the two Southern Hsien of Jui-an and P'ing-yang, and the almost circular bowl-shaped plain surrounding Wenchow city and having a diameter, at its widest part, of about eleven miles, the whole prefecture is an almost chaotic riot of mountains rising to between 3000 and 4000 ft, mostly bare of trees and given over chiefly to the cultivation of sweet potatoes and the growth of wild vegetation for fuel. Many of the mountains

Geographical
and
Topographical

are masses of extremely precipitous cliffs with fine cave and temple scenery, and frequently taking fantastic shapes which give poetic names to their neighbouring villages. Thousands of rills and rushing streams, leaping cataracts and foaming falls intersect the innumerable valleys which, while adding beauty to the scenery and bringing nourishment to the growing crops, often in their numerous flood-times prevent the pastors and preachers getting to their appointments. Many of the churches are situated on both banks of the main river and of its tributaries, about a dozen are out at sea, and half-a-dozen in Wenchow city, but the great majority are among and on the mountains, entailing two and three days' journey to them by river houseboat, by sampan, by "grasshopper boats"—a special kind of boat for negotiating the many rapids, by sea-going native sailing craft, by foot and by mountain chair. A small native steamer is helpful now for getting to about half-a-dozen churches out at sea, and a small canal-going steam launch is available for a few churches near the canals.

The Wenchow mission work flows over into two other prefectures, Chüehow and T'achow. The churches are grouped into two sections, Eastern and Western, each having a missionary as general superintendent, with five circuits of about 150 Churches in the former, and four circuits of 120 in the latter. The China Mission Year Book for 1915 gives the average number of Protestant churches per missionary as four. In 1896 the average per missionary here was 80; in 1922 it was 135; and from Sept. 1922 when the superintendent of the Eastern section broke down in health and was invalided home and the principal of the college of 188 students was on furlough—until March 1923 when Rev. A. H. Sharman returned to relieve the writer of the general work of the mission, the writer had to take the oversight of all 270 churches, pastors, local preachers, schools, the chairmanship and secretaryship of the district, much heavy financial and accountant work, having at the same time the principalship of the college which entailed teaching English subjects on six days of the week. On the top of this came the worst typhoon within living memory which totally destroyed ten churches

besides serious damage to many more, and to the residential property and college and city schools to the extent of nearly \$20,000: he had to get into touch with the home churches for relief funds and start on restoration work and repairs.

**Pastors,
Preachers,
and Duties**

Each circuit has one or more resident Chinese pastors, the superintendent pastor of the circuit living at the house adjoining the "Circuit Chapel", the assistant pastor or pastors in other parts of the circuit on mission property. The superintendent pastor receives a foreign grant from time to time according to an approximate estimate of the preceding year. He pays all circuit expenses such as rents, local preachers, expenses, repairs, lighting and heating, caretakers, teachers, salaries &c., and keeps a regular account with the missionary for the same. He sees that preaching plans are put into the hands of the local preachers, arranges for the bi-annual district or circuit meetings, reports to those meetings the non-attendances at appointments of all the local and other preachers, and is chairman of the committee of the Thanksgiving Fund of his circuit besides the usual duties of a preaching pastor. The qualifications and training of the pastors differ greatly, from the pastor of many years' standing who was appointed by the missionary-in-charge in those earlier years for his general Bible knowledge, his Christian character, zeal and reputed common sense, to the man of the present who has had three or more years training in Nanking Theological Seminary or in Peking. The first men to get any systematic training were three young countrymen sent for a year or so to our own college here for training under the Chinese master in character and literature, and to read some Christian literature with a pastor. That was nearly 20 years ago. Then about 12 years ago six young men were placed for two years under the care of one of our best pastors, living with him at the circuit chapel, reading Christian literature with him, taking lessons in Chinese composition and literature with the resident schoolmaster, taking preaching appointments at the week-ends in the different churches of the circuit, and seeing at first sight the actual working of a circuit.

Now-a-days there are two methods as in our English churches; according to the first a young man who has been recommended by his church and circuit meeting, after passing the tests imposed, is appointed to a circuit under a suitable senior pastor. Certain books are set for study for the year and the pastor is expected to supervise his studies and give him assistance. He is appointed to take Sunday and week-night services in the circuit, and near the end of the year an examining board of pastors gives him a written examination on the books studied; he also preaches a trial sermon. Marks are assigned for these and if these and his circuit record are satisfactory he passes on to his next year. At the end of four years probation, if still satisfactory he becomes a junior minister. According to the second method the young man is sent to Nanking or Peking for training and, as he has before that had experience as a local preacher in Christian Endeavor or Sunday School work, his record at those institutions is accepted and he is appointed as a junior minister.

The great bulk of the Sunday services is taken by the local preachers. In the earlier years of the mission these men had practically no special training beyond occasional Bible classes of a week or ten days in their circuits, generally taken by the Chinese pastor, once or twice in the year. Hitherto the foreign missionary has seldom been able to take these classes: such is the acuteness of understaffing, that itineration and general work have taken up so much time. For some years besides such Bible classes a summer school of four weeks or more has been held in the city each year for all local preachers from all the circuits who care to come. The foreign funds supply a grant-in-aid which is supplemented by generous subscriptions by two of the wealthier city members, and those who attend make some contribution. Further every local preacher is supplied with the Sunday School Lessons every quarter, and it is expected that in every Church the preacher will take the lesson for the day at the Sunday afternoon service. This ensures systematic preparation for at least one service on Sunday.

There are two classes of local preachers: (1) The regular men who are paid a sum to cover food and travelling

expenses according to the distance of the appointment. (2) voluntary preachers who take services which require absence from home only for the Sunday morning and afternoon. Some of the regular men volunteer one, two, or more Sunday appointments per quarter. Every quarter a plan of the whole of the services is drawn up, and a copy given to each preacher, the churches also being supplied with them, near the end of the preceding quarter.

Organization The limits set to this article allow of little more than the merest reference to organization. Circuits have from about a dozen to over 30 churches. In the spring and the autumn each circuit has a district or circuit meeting attended by representatives from all the circuit and the local preachers. The contributions of the Church members are brought by the representatives and handed in to the superintendent, the church registers are examined, cases of discipline or restoration investigated and decided, the church rolls corrected, the state of the churches inquired into, appointments of preachers reported as to absences and explanations heard, all financial and statistical returns required for the annual conference prepared, and recommendations for the ministry received. During the first half of the first Chinese month of the year the annual conference is held, pastoral sessions being held beforehand. All reports are received here for the Home Board. The Chinese pastors take their turn with the foreign missionary in the chairmanship of these meetings as also at the circuit meetings. At the annual conference special attention is given to the reports and condition of the different circuit Thanksgiving Fund, each circuit treasurer having to give his own report. This fund was begun 15 years ago, each circuit having its own treasurer and committee one of whom must be the Chinese superintendent minister. With the funds land is bought, houses built and other investments made, rent and interest being added to the principal until \$2,000 is reached when the income from it goes towards the expenses of the work. Two circuits have passed the limit and one or two others are within sight of it. As this is a purely native contribution its administration is entirely in Chinese hands

subject to the control of the circuit meetings where its officers are elected.

Weaknesses (1) Understaffing. With such an extensive work and the number of foreign missionaries having been perennially far short of anything approaching sufficiency, it has been quite impossible to keep up such constant direct contact with the majority of the churches as is necessary for tutorial work and for intensiveness, which latter has had to be sacrificed to extension.

(2) The size of the circuits, the long distances and generally mountainous character of the country between the churches in the circuits has militated seriously against the holding of catechumen classes by the pastors, and thus candidates for baptism have too often had to do the best they could themselves in learning the merest rudiments of the faith, a short catechism of which is inserted in the end of our hymn-books, or get what intermittent help they could at the Sunday or other services from the preacher appointed for the day or from other members. Latterly we have had copies of Dr. Price's catechisms put into the hands of the preachers including the local preachers and they are expected to give a little time on the Saturday evening or between or before or after Sunday services to instruct would-be learners of the same.

(3) The financial problem presses very hard. The vast majority of our people are poor farmers, labourers and shop-keepers, and the greatness of the work demands so much of the comparatively small home grant that the pastors have had to be content with very small salaries, so small in some cases that some of them have eked it out by selling medicine, or by giving more time to the oversight of their paternal acres than is consonant with the proper pastoral oversight of the churches under their care. This is gradually being remedied, but the evil of absence from their circuits has apparently become a habit with not a few. This would possibly be more speedily and effectively remedied if the salaries were altogether forthcoming from the Chinese Christian, but they are too fond of pleading, and the plea is to the writer's knowledge nearly 30 years old, that they are still infants in need of the bottle from

the mother church in England. It is expected that when the Thanksgiving Fund of the circuits has each reached the \$2,000 mark and interest is being paid into the general fund, the salaries of pastors can be more easily increased, though it is said among the pastors that the local preachers will not consent to this but will expect that the pastors' salaries will continue to be paid out of the foreign grant. The Thanksgiving Fund too occasions no little trouble, and the missionary often has to be called in to take a very firm stand against cases of serious abuse of the funds. Not a few of the local preachers too while absenting themselves from their preaching appointments still claim the amount of expenses, and the circuit minister is not always strong enough to take a firm stand against the evil. Occasionally too, indeed it might be said, not infrequently local preachers arrange with each other to exchange appointments to save themselves long journeys, or they get some one else to go for them at a reduced fee, themselves pocketing the balance. The number of lapsed appointments mostly through flood and stress of weather, though not by any means always so, is sometimes quite serious, and may have not a little to do with the noticeable decrease in attendance. Evidently one or other missionary in charge had found the evil so prevalent that he felt compelled to bribe the preachers with the promise of a gift of literature to each one who fulfilled his appointments for the year.

(4) There are about 5,000 women and girls connected with our churches and what little work has been done among them (and that only in the city) has had to be done by missionaries' wives who have had no training and have had to pick up a smattering of the language they have gained amid the duties of house keeping and bringing up of their families. A fortnight ago the first trained lady-worker — a deaconess from the home churches — came to engage in evangelistic work among the women and girls. For thirty years we have pleaded for such to be sent, and it speaks volumes for the simple faith and earnestness of our Chinese women, nay it is surely a miracle of faith and earnestness, that in spite of such utter neglect of the great majority of them by their sisters in the home lands, after

46 years there should be such a great number. What a commentary on the words "The harvest truly is plenteous but the labourers are few"!

Besides the above there is the work of the college with 213 students, the girls' school with over 60 pupils, and the hospital with one foreign Doctor, over 36,000 out-patients, 1,187 male and 492 female inpatients, amongst whom Christian work in the form of preaching and teaching is carried on in the dispensary chapel and in the wards. Formerly to any patient who became interested a note was given by the doctor to take to the pastor of the Church nearest the patient's home and the pastor was notified also so that he could follow up the case. This work has been fruitful in bringing many into the church.

It may not be amiss here to add that for the further help of all preachers the foreign fund stands half the cost of books helpful to their Christian work of teaching and preaching, and arrangements have been made for some time with a large book-store in the city to accept the printed and signed slip given by the missionary to preachers for such literature, and these slips are brought quarterly and payment of the half made in a lump sum.

It remains to add that last year the most of the \$443.99 subscribed to the Thanksgiving Fund by the Chinese was voted by them to typhoon relief, and that when the rate of exchange was most adverse, the Chinese pastors nearly all subscribed a month's salary or thereabouts to help out the stringency.

CHAPTER XXIV

TENT EVANGELISM

Andrew Thomson

The changed conditions of recent years, and the success attending the use of tents by other missions, induced us to make the experiment for ourselves. By the end of 1923, including both the mission and independent congregations, there were eleven tents in use, and we expect to add to this number in 1924.

The tent affords the double advantage of a better auditorium than can generally be found ready-to-hand in Chinese cities or towns, and of mobility. It can be set up almost anywhere, in a short time, and is equally adapted for village, town or city work. Situated at a place accessible to the general public, furnished with portable benches, platform and table, with pictures and hymn and text sheets, it releases the speaker from an unequal contest with the din of street traffic, and affords the hearer an opportunity of listening in comfort and without distraction to the message of the evangelists.

Method of Work

The writer will be pardoned if he confines himself to that in his own experience which he has found useful. Before going to the centre selected for work, we secure a site for the tent, and, as near it as possible, quarters for the staff, and issue printed notices about the meetings. By first approaching the leading men of the place, the site is usually granted free and sometimes commodious quarters in temples are also granted without charge for the accommodation of the staff. Three meetings are held each day—morning, afternoon and evening—the last being the largest, as the business and the work of the day being over, all classes are free to attend. A part of the tent, with a separate entrance, is reserved for the women, sometimes being divided from the rest by a partition of straw mats nailed to a wooden

frame, sometimes simply by an aisle between the benches. A pleasing feature of the meetings is the large number of women who attend, especially in the evening.

The preaching band consists of missionary or missionaries, and from three to six Chinese speakers. In addition, two men are employed to watch the tent, (they sleep in it overnight) sweep and sprinkle the floor, arrange the benches, etc. Local Christians are of service in ushering and maintaining order. The program of subjects may be arranged in advance, and each speaker assigned his place in it. The topics can be selected and arranged so as to make an orderly development throughout the meetings. Thus, for example, starting with such subjects as God, Man, one may proceed through the leading events in the Life of Christ and Principles of His Teaching, to Prayer, the Bible, the Church, the Home, and Society. This method permits of each address standing out complete and distinct by itself, prevents undue over-lapping and repetition, restrains discursive brethren from wandering too far afield, and in the course of twelve days or two weeks, makes possible an orderly presentation of the leading doctrines and practices of the Christian faith.

While the meetings are in progress, provision is made for inviting any interested to retire, usually to the place where the staff is residing, where, over the social cup of tea, they may ask the questions that the new things they have heard raise in their minds. Both in the tent and the guest room, literature is on hand for sale or judicious presentation.

One problem that arises is, what to do with the children. These attend in large numbers, and, unless controlled, monopolize the seats and create disorder. To expel them is to increase, rather than diminish this, and is scarcely in keeping with the object we have in view. A plan which has been found quite practicable, and which offends neither old nor young, is to announce that a short address will be given to the children at the beginning of the meeting, let them have the front benches, give them their talk with the help of pictures, teach them to sing a verse of a hymn, and then ask them, as they have

already had their turn, and as propriety demands that the young should show deference to their seniors, to vacate the benches in favor of the grown-ups.

Our mission is now using several preaching bands, each with its own equipment. We have also in operation a system of exchanges between the stations, both of foreign and Chinese workers. The workers themselves reap the benefit of an exchange of views and methods of work, and our church members have the opportunity of hearing new and fresh presentations of the message.

Advantages There are some special advantages from this method of work which may be noted.

1. The close association of the missionary and his Chinese fellow-workers, the daily united prayer and Bible study, the discussion and criticism of the addresses delivered in the tent, furnish an admirable training-ground for the future leaders of the Chinese Church.

2. By grouping workers into a band during a part of each year, equipped with a tent and furnishings, and by going to each man's district in turn, each reaps the benefit of the united strength of the whole.

3. When the tent leaves the place where it has been, no church property is left behind to be cared for. Premises provided by mission funds are open to the objection that they are frequently idle for a large part of the year, and become the loafing-place of undesirable hangers-on. With the tent it is otherwise.

Extent to Which Used Letters of enquiry regarding use of tents secured answers from fourteen correspondents, reporting twenty-seven tents in use, three in Shantung, two in Chili and twenty-two in Honan. In all cases they have come into use quite recently, the earliest date being seven years ago. The tents vary in size from 30' x 20' to 60' x 40' and one 72' x 36'. One tent, foreign canvas, made in Shanghai, can be secured in various sizes — 45' x 25', up to 70' x 40'. Two writers mentioned *quality* — "it pays to get a really good one."

General Method It was evident from the replies received that the tents are not used to cover a lot of ground hurriedly, but for concentrated work at chosen centres by a large staff over a period from a week up to two

months. The average period was seventeen days. The preaching staff varied from two full-time men with lay assistance from neighboring congregations to ten men. The equipment included cooking utensils for Chinese staff, table, benches, platform, organ, stereopticon, gasoline, carbide and kerosene lamps (in the case of one city, electric lights) and in one case, band instruments.

It was also apparent that tents are being used both in new districts and also where there are already well-established churches. In some cases the Christians cooperate both in the preaching and in meeting the expense involved.

Children's Services For children special services were recommended, either before the main service, or "by having special meetings for them in separate tent or building".

Women's Meetings The replies favored joint meetings for men and women in the tent, with separate quarters for receiving women enquirers.

Unanimously Approved One question was, "Do you recommend this form of work as advantageous?"

Without exception, the eleven correspondents gave a hearty affirmative answer. Here are three:

"Yes, indeed, many feel free to attend tent meetings who would never go into a church."

"Yes, it is splendid, the people are keen to hear and would always have us remain double the time".

"Yes, it is the best form of evangelistic work ever carried out here. Honan village system suited to this form of work."

(For outline of equipment see "Tent equipment" Appendices)

CHAPTER XXXV

WORK AMONG THE SHANS

J. W. Lowrie

Origin A Shan is defined by a standard dictionary to be "a member of the group of Mongoloid tribes of the Tai stock, physically and linguistically allied to the Siamese, found throughout Indo-China."

The term 'Shan' seems to be a Burmese word whose origin is uncertain. It is unknown among the Chinese, who call the Tai people "By E", the word "E" meaning gentile and the word "By" being given different interpretations by different individuals. The Chinese also divide them into "Han By E" and "Shway By E", which means respectively the dry or land Tai and the water Tai, referring in the latter case to their residence in the vicinity of a river and their skill in the art of irrigation. The word Tai in their own tongue means free.

It seems that the Tai were a numerous people before the Christian era, occupying the northwestern region of China but gradually driven southward by the more powerful Chinese.

They established a capital city at Talifu in Yunnan Province from which they were expelled by the Mongols in the thirteenth century and successively planted other capital cities on the Mekong river, at Chiengmai in Siam and finally at Bangkok, the present capital of that country.

In Siam the race has revealed its capacity to advance and to make use of the attainments in science and of the conveniences of modern civilization enjoyed by western peoples.

The Tai are found in larger or smaller groups from the French territory, Tongking, and Kwangsi Province in China on the east across the Provinces of Kweichow and Yunnan into eastern Burma.

In many of these localities the people have accommodated themselves to the ruling race whose language they use freely. But in Kweichow there is said to be a large population who still speak their native dialect, and in southwestern Yunnan there are probably one million of them who retain the language and customs of their ancestors.

Characteristics The Tai people have some very attractive national characteristics. They are simple and natural in manner, fond of flowers and of human fellowship. They are much given to laughter; in this respect being given the preëminence by the traveler, Geil, over all the peoples of the world. The costume of their women is tasteful and beautiful. They use small, hollow, half spheres of silver which they sew upon their collars and jackets in large diamond shaped figures with a striking and attractive effect. Men and women are diligent in tilling the soil and have become especially skillful in bringing water from a long distance for irrigating their rice fields.

In the region where the bamboo is abundant, their houses are made largely from its rods and split strips and have heavy thatched roofs. In the more northern region the people build strong houses of stone with low flat roofs, each adjoining that of its neighbor, so that the whole village population can circulate freely from end to end upon the roofs of their houses, which at the same time are impregnable to the ordinary robber bands.

Religion The Tai of the extreme south and west of Yunnan Province are Buddhistic, and Buddhist temples are found in every large village. Buddhist priests enjoy the same reverence and receive the same support from the people at large as in the Kingdom of Siam where Buddhism as a faith has found its most congenial home.

Missions Christian Missions have been carried on amongst the Siamese people since the middle of last century by missionaries of the American Presbyterian Church, and from that mission pioneer evangelists followed the Tai communities northward until they reached

the wide area in the extreme southern districts of Yunnan Province called Sip Song Panna, which means the twelve wide rice plains.

There on the Mekong river, about 22° N. latitude and 101° E. longitude, within the limits of an ancient capital city of the race, whose traces in moat and wall are now barely discernible, these missionaries planted an out-station called in the Tai language Chieng Rung (or Hung) but called in Chinese Kiulungkiang. At this place resides the Chinese ruler of that portion of south China, at present a very capable man, who, with perhaps a thousand soldiers scattered throughout the whole area, keeps the peace between contending Tai communities and makes it possible for missionaries from the west to reside there in peace and safety. But for this Chinese mandarin there would be no regular mail service to Kiulungkiang nor, possibly, would the safety of a western family be insured for any considerable length of time, for by his impartiality, kindly spirit and manifest wisdom the hostility of the people to the Chinese, their conquerors, is much abated, and their ever-recurring tribal feuds eliminated.

The station is twenty-four days' journey from Yunnan on the north and twenty-eight days from Chiengmai in Siam on the south. A dispensary and schools have been opened at this point and a little church is planted there where rest the remains of Rev. W. C. Dodd, D.D., who loved the Tai people with ardent affection and spent the last years of his life seeking them out in their scattered dwelling places and bringing them to the notice of the Christian world that they might hear the Gospel and live.

The Rev. Mr. Young of the American Baptist Mission, a zealous pioneer evangelist, is laboring with success in the southwestern section of Yunnan Province in what is also one of the most isolated mission centers in the world. Particulars of the work of this devoted laborer are not obtainable at this writing.

Mr. and Mrs. J. Fullerton, independent missionaries located for some years at Szemao, a large and prosperous Chinese city in southern Yunnan, are laboring with two or three missionary comrades at Menglieh, seven days' journey east of Szemao, where over a thousand members of the

Lisu tribe have accepted the Gospel. Rev. J.O. Fraser of the China Inland Mission is also engaged in a successful work among the Lisu in the southwestern portion of Yunnan Province near the Burman frontier and has translated one of the gospels into the language of the Lisu people.

Some eighteen days' journey north of Kiulungkiang and about six from Yunnanfu is the city of Yuankiang on the banks of the river of the same name. This river flows between two mountain areas that are seven thousand feet in height, itself at the low level of but fifteen hundred feet above the sea. The river valley is therefore fiercely hot in summer and subject to malignant malaria also. So much is this the case that the Chinese people fear to dwell along the river bank and have left some thirty thousand of the Tai people undisturbed in their tillage of the soil and enjoyment of the fruits of the earth. These thirty thousand Tai have no political or social relation to the millions of their family in the distant south nor are they Buddhists in faith, but are pure animists, living in constant dread of the evil spirits with which they people the unseen world and protecting themselves from the malign influence of these spirits by amulets and charms hung at the doorways of their houses.

Pioneer Missionaries Two years ago, pioneer missionaries from Kiulungkiang, speaking the Tai dialect, providentially met members of this community and were received with open arms. The message of the One who is greater than the demons and could bring peace to their homes and communities was received with enthusiasm by hundreds, and at the present time about two thousand are studying the Christian faith under evangelists brought from Siam and are learning to read the scriptures printed on the presses in Siam, whose language is substantially the same as their own. The American Presbyterian Church has sent four families from its Siam Mission to open the new work in China and also seven mission recruits from America to push the work so auspiciously begun.



CHAPTER XXXVI

WORK IN HAINAN

David S. Tappan

Hainan Island the most southern part of China, is in the same latitude, 18-20 degrees North, as Porto Rico, and is about the same size as Formosa. Politically it is a part of Kwangtung Province but the Hainanese language in idiom is like Mandarin so that Mandarin literature is in common use. There are large settlements of Hakkas and several large Mandarin speaking markets while many of the business men of Hoihow are Cantonese. Many Hainanese emigrate to Siam and Singapore in search of wealth and returning home find themselves Enoch Ardens. Although no census has ever been taken it is estimated that there is a population of 2,500,000. There are no large cities, Hoihow the chief port, being the largest with about 40,000

people. It has no harbor, but an anchorage two miles out where steamers from Hongkong take on coolies for Haiphong and Bangkok, and cattle, pigs and chickens back to Hongkong. This twenty-six hours trip to Hongkong lies between Hainan and the rest of the world, and two or three steamers a week are the connecting link.

Climate The tropical climate is no help as it takes away zest for work and prevents Westerners as well as Chinese from accomplishing as much as people in cooler, more invigorating zones. The new missionary needs a steel will to keep at language study during the long summer days. Four months, December to March, are cool and brisk and dark clothing is a welcome relief from the common garb of white duck suits.

Communications The lack of roads and modern means of communication are handicaps to the spread of Christianity. A trip across the island takes ten days, a distance with modern roads easily travelled in a few hours. The advantage of roads, however, is beginning to penetrate and the present thirty miles of real road travelled by four or five Fords is but the beginning of a new era. Recently a telephone line twenty-five miles in length has been built and the government plans to thus connect the thirteen district cities.

Politics Political chaos since the Republic has greatly hindered development. Little can be done to mine the gold and tin to be found in the interior, nor can large tracts of land now lying idle be used as long as cattle thieves and bandits run unmolested. At present lottery and gambling are eating into the economic life of the people and, with opium, bringing moral disaster.

The scientific world has recently been attracted to Hainan as a field of research almost new. New species of fauna have been discovered by Clifford Pope of the Roy Andrew's Expedition. F. A. McClure of Canton Christian College found seventy new species of plant life.

Catholic Missionaries Mission work was opened by the Catholics in the sixteenth century but modern Catholic work began in 1849. At present the work is carried on by a few French priests and sisters.

Pioneer Protestant Missionary Carl C. Jeremiasen was the Protestant pioneer missionary of Hainan. In 1881 he began work and four years later became associated with the American Presbyterian Mission. This mission has continued to have entire responsibility for bringing Christianity to Hainan Island and Luichow Peninsula on the mainland. At present there are thirty-four missionaries in the three stations, Kiungchow-Hoihow, Nodoa, Kachek.

Chinese Pastors Because of its isolation, mission work in Hainan is at least twenty years behind other parts of China. There are only two ordained Chinese pastors with two more soon to be ordained. Hence the question of Chinese assuming full control is in the future. However the Hainanese church is a part of the Church of Christ in China, and as such sent two Chinese delegates to the National Christian Conference.

Bible Institute Hainan Bible Institute was opened Nov. 5, 1923, with twelve students. The Milton Stewart Evangelistic Fund has made this work possible by a gift of \$7,000 gold for buildings and an annual appropriation for upkeep. It receives middle school and higher primary graduates, and prepares evangelists and preachers.

Loi and Miao In the interior of the island a great opportunity for evangelism has been found among the Loi and Miao tribes. The mass movement towards Christianity among the Miaos has brought whole villages to Christ. They have built for themselves 12 chapels, have ninety pupils in four schools and about one hundred and fifty have been admitted into the church. The Loi aborigines have five chapels, one school of twenty pupils. Twenty have been baptized.

Church The following figures show the rapid growth of the native church.

1892	78	Christians.
1900	106	„
1909	375	„
1917	1,642	„
1922	2,890	„
1923	3,419	„

This is an increase of over 18% in one year. A complete system of schools from the primary through the middle school is maintained by the mission, but much needs to be done for the proper supervision of the country schools. Lower and higher primary schools for boys and girls are provided in each station. Since 1919 the mission has centralized its middle school work at Kiungechow in the Hainan Christian Middle School for Boys, and Pitkin Memorial School for Girls. The two schools are on adjacent property and have a common faculty.

Boys' School The boys' middle school serves the community and helps to create good will by yearly holding the only interscholastic middle school field meet in Hainan. On Dec. 14, 1923 all the government schools of Kiungechow attended, making a crowd of several thousand spectators.

The Middle school students are being trained in Christian service by the Christian Endeavor. Through its agency they hold regular Sunday services at the jail with a special treat and program at Christmas time. They maintain a street chapel in the city of Kiungechow with weekly services and last summer conducted four Daily Vacation Bible schools.

Girls' School An unsolved problem at present is that of the future of the graduates of the girls' middle school. In the transition between the old and the new their changing social position causes blunders. Of twenty-four graduates fifteen are teaching, and three are away at school. Some have brought disappointment by marrying into wealthy families as second wives rather than return to the crude homes from which they have come.

The following figures tell the story of the growth of the educational work from the time when ten cash had to be paid to each student to attend school, to the present when \$25,652 was received in school fees during 1923.

1892	74	students, mostly primary.
1900	86	„
1909	281	„
1917	1500	„
1923	1742	„ (middle schools, 150.)

There have been 48 graduates from Hainan Christian Middle School since 1920. Twenty-five are attending college in other parts of China or in America. Twenty are engaged in teaching, twelve of whom are in charge of schools connected with the mission.

Medical Work Mission hospitals are located in Hoihow, Nodoa and Kachek. During 1923 the Hoihow hospital treated 15,000 out-patients, 1950 in-patients, and 430 maternity cases each of a month's duration, besides 200 severe surgical operations. Dr. McCandliss, who founded the hospital over thirty years ago, recently removed from the bladder of a patient a gall stone weighing 17½ ounces, supposedly the largest in medical history. The patient recovered and was able to return to his home. The hospital has been self-supporting for years and last year took in fees amounting to \$22,000.

Nodoa hospital, ninety miles in the interior, — four days of hard travel, — is an oasis of healing. It is equipped with an X-Ray machine, electric lights, ice-making machine, windmill and running water system.

Kachek hospital is beginning a new era of work with its new building, costing \$50,000 Mex., given by the Dallas City Temple, Texas, which has also taken over Kachek station as its parish abroad. Both Kachek and Hoihow hospitals carry on work for lepers in their villages where free clinics and religious services are held weekly.

CHAPTER XXXVII

WORK AMONG TURKI AND THE TRIBES IN CENTRAL ASIA

G. W. Hunter

The Asia treated below extends from Kashgar in the West to Kobdo in the East. In this vast territory are to be found Sart Turki, Qazaqs, Khirgiz, Mongols, Tongans, Manchus, and Chinese. The Sarts occupy the cities and towns on the south side of the T'ien Shan range, from Hami to Kashgar, they are also to be found in the towns along the Sinkiang Thibetan border.

Chinese and
Tongans

The Chinese and Tongans occupy the cities and towns on the North side of the T'ien Shan from Barkul Ili (Kul ja). There are also quite a number of Tongans in Hami, Turfan and Karashar.

The Manchus are mostly in Ili and Taheheng (Tarbakatai). The Qazaqs and Mongols pitch their tents in the valleys on the northern slopes of the T'ien Shan and also in the districts of Tarbakatai, Altai and Kobdo.

The Khirgiz are found in the mountains near Kashgar and Uch Turfan, and in Karashar is a large tribe of Kalmuk Mongols.

Settled work has been carried on by the Swedish Missionary Society in Kashgar and Yarkand for about 30 years. They have established an orphanage, hospital and schools. Naturally their work is mostly amongst the Sart Turki as there are practically no Chinese on the south side of the T'ien Shan. The Sarts are amongst the most ignorant and bigoted of Mohammedans, but the Grace of God has much more abounded and this last summer about eight were baptized, followed by bitter protests and persecution. The mission has its own printing press, and prints tracts, scripture portions and educational books in Turki. The four Gospels, translated in the early days of the mission and printed by the British and Foreign Bible

Society, were followed recently by the whole of the New Testament. A great deal of medical work is carried on and the Khirgiz are sometimes visited in the mountains near Kashgar.

Tihwafu About 46 days' journey east of Kashgar is the city of Tihwafu known by its old Mongol name Urumchi, whilst the local Chinese name is Hong Miao Tsi (Red Temple). Tihwafu has a mixed population of Chinese, Tongans, and Turki, amounting to about 60,000 in all; in the surrounding mountains are many Qazaqs and a few Mongols.

The China Inland Mission opened a station here in 1905 and at present there are two resident missionaries. The nearest mission station is at Kanchow in Kansu, 42 days' journey distant.

The work in Tihwa is not easy as the people are mixed and very unsettled. In spring thousands of Chinese and Tongans set off for the Russian border to plant opium, or flock to Altai to dig gold.

The Work The work consists mostly of bookselling and street preaching with a little dispensary work. In spring a visit is generally paid to the district of Ku C'heng Tsi where there are many Chinese. In summer long journeys are usually taken amongst the nomad Qazaq and Mongol tribes in the districts of Karashar, Ili, Tahcheng, Altai, Kobdo, or Barkul. Journeys have also been made to K'u ch'ae, Kashgar and Yarkand, and Khotan. This summer a journey was made to Lanchow, 56 days' journey south east of Tihwafu.

Literary Work Literary work has not been altogether neglected. The Gospel of Mark, The Acts, Samuel and a portion of Genesis, "Pilgrims Progress" and a few tracts have been translated into simple Turki.

The Gospel of Mark and the Book of Acts have been translated into Qazaq. Several hundred copies of most of the above have been printed on a small hand mimeograph and distributed amongst the people, previous to their being printed by the British and Foreign Bible Society.

A Kalmuk Mongol Grammar and Dictionary is also in preparation.

Conditions The Government, which is of the most despotic, conservative and backward type, is anti-Christian. No newspapers are allowed to be printed in Sinkiang, and all Chinese, Turki and Arabic newspapers are confiscated. A rigid censorship of letters has been carried out for many years: native letters are sometimes censored twice.

The people are rough and independent. The Chinese and Manchus are addicted to opium. The Turki people possess all the immoralities of a debased Mohammedanism. The Mongols are drunkards and many of the Qazaqs and Tongans are thieves.

Results Five Chinese and one Tongan have been baptized. The latter, a young man, wrote out a confession of his faith in Christ and boldly hung it outside the chapel door when we were away from home last summer. He has suffered beating and not a little persecution.

The Turki people who formerly used to burn our tracts, etc., in public are now outwardly becoming more friendly and we believe that amongst them are secret believers.

No fruit has been seen amongst the Qazaqs or Mongols, but a few have heard the Gospel and many gospels have been left in the lonely tents between Karashar and Kobdo and we believe that God's word shall not return unto Him void.

PART VI
MISSIONS AND MISSIONARIES
CHAPTER XXXVIII

THE FINANCIAL RESOURCES OF THE HOME BASE

J. L. Stuart

The experience drawn on for this article is confined to the United States, although conditions in Canada are perhaps essentially the same, and in Europe at least no more encouraging.

**Mission Work
Established** Perhaps the first impression one receives is the fading out of the old objection about not believing in Foreign Missions. Improved facilities for travel, new international relations, the after-effects of the Great War, have perhaps all helped the churches to realize their obligations overseas. At any rate the abstract claims of missionary work seem now to be quite generally recognized among religious people. These now take their place along with other good causes, and require no special advocacy as such.

**Interest in
China** A second pleasant impression is the friendly and relatively well-informed interest in China which is wide-spread. This kindly attitude among Americans of all classes is somewhat surprising. But it is from the missionary's view-point the most popular country for which to plead, the easiest for which to secure contributions.

It would seem that these two phenomena encourage the hope of constantly increasing support for various aspects of missionary activity in China. Such hope is certainly justified and should enter into our planning. There are, however, certain qualifying factors which deserve our thoughtful attention.

Volume of Appropriations For one thing, there has already been a notable advance in the volume of appropriations to China. With constantly higher cost of operation and normal expansion, there must be a steady increase in annual appropriations merely to keep up existing work on its present basis. Can this be looked for or have the available resources of the western churches been drawn upon to their limit? It is a pertinent question involving both economic and spiritual issues. Obviously there is only one answer when one sees the enormous wealth and the abandon of spending everywhere in the States, or when one reminds himself in reverent trust that all things are possible with the God we serve. Yet, while realizing the rich significance of both these considerations, we cannot afford to disregard other factors in the present situation.

Business Depression There has been for several years a business depression which, while lifting somewhat this year, is still threatening. Many financial authorities express the fear that it will return, and will not finally clear away until European affairs become stable, of which there seems to be slight prospect just yet. The heavy taxation, especially on the wealthy; the shifts of fortune by which those accustomed to money and to dispensing it have in numberless instances had their incomes reduced, and others have suddenly found themselves rich but without training in any sense of stewardship; the caution which paralyzes the nerve of generosity in unsettled times; the changing standards of comfort and luxury and the temptations to reckless expenditure—these are suggestions of general economic conditions which have their bearing on our interests.

Board Deficits Practically all the mission boards have been carrying heavy deficits. Some of these have with the utmost exertion during these autumn months cleared this off or reduced it. Such conditions are symptomatic of something wrong.

This much at least seems clear, that all the mission boards are sufficiently involved to indicate a general condition rather than the consequences of an unwise policy on the part of any one board, and that for some years at any rate they

will all have to put their major emphasis upon adjusting their expenditures to their normal receipts rather than to any expansion of work.

The majority of strong denominations and nearly all the local churches have adopted a budget system by which special appeals are ruled out and only the schedules for foreign missions, which can bear the scrutiny of a joint council, are approved. This tends to reduce such items to the necessary minimum, and permits but small enlargement through official channels.

Philanthropy Philanthropy in America has become more highly organized and embraces a wide compass of activities both in this country and in Europe and the Near East. The appeals for charity are numerous and insistent. The very broadening of outlook, which has swept away hostility to foreign missions, has opened the hearts of our people to humanitarian claims in all parts of the world. The response to the earthquake in Japan is a striking instance of this.

The "drives" that were instituted during the war have developed a technique for campaigning which is relentlessly effective in its methods. Every type of religious or social welfare financial appeal either employs experts or snatches a leaf or two from their manuals on tactics. This generates in turn a protective armament on the part of prospective donors.

There is now a psychological revulsion against the very thought of another appeal. Despite — or because of it — the almost uncanny ingenuity of appeals by mail, these are now recognised as almost worthless for bringing results. One may rejoice in the growing response to appeals, many of which are essentially missionary in spirit, while facing the arresting thought that foreign missions in the technical sense must compete with many vigorous agencies in their demand upon the Christian heart and conscience.

Chinese Support There is another note to which we must give heed. People are asking about Chinese support of our undertakings.

American Christianity Finally the spiritual condition of American Christianity gives one pause. The theological controversy now raging cannot but divert the

interest of many from aggressive financial efforts, shake confidence in official boards, and otherwise injure missionary support. The revolt of our youth against existing expressions of Christian faith and activity may mean that with the passing of the older generation, there will be a weakening of the agencies on which we now depend, at least until the church and the resurgent spirit of youth find a way for adjusting the old doctrines to new demands. The break-down of Sunday observance, the automobiles, the radio, the movies, are affecting at least the ordered forms of church life. One need have no doubt of the ultimate victory of Christian faith over all disturbing tendencies now manifesting themselves in American life, even though he fears that in the years just ahead they may seriously affect the growth in missionary receipts through established agencies.

Implications To sum it all up, hard facts force one to the conclusion that wise missionary policy will shape its program on the expectation that the income from abroad will not materially increase in the near future and may even be reduced.

If this contention is true, it has important implications for China mission policy. We all recognise the strategical value of more Chinese workers in every phase of the Christian movement. This requires increased emphasis on the facilities for training such men and women, and increased budgets for their salaries and for the plants necessary to retain and make effective their services. But if we must provide for these and other obviously desirable features of a policy that looks to strengthening the Chinese contingent in our forces, if we are to concern ourselves with higher standards and finer quality, especially in matters of Chinese leadership, this can only be achieved by resolutely reducing the reinforcements from abroad and the maintenance of foreign-manned activities. It would seem that we must choose between intensive and extensive effort, between more money for developing Chinese workers or for bringing over more of our own nationals.

CHAPTER XXXIX

WHAT SHOULD BE THE PRESENT CONTRIBUTION OF MISSIONS TO CHRISTIAN WORK IN CHINA

T. K. Shen

It is said that the last words of St. Francis Xavier while dying on the island of San-chan and seeing the great mountains of Macao were a prayer that the great rock would give an opening to Christ. About four centuries have elapsed and we of this day see the opening indeed! Cities are thrown open for Christian missionary work, barriers are broken down, homes of the gentry are opened, children of the conservatives are tutored. We might say with St. Paul that Cæsar's household is beginning to be evangelized.

The loving labors of faithful pioneers and the liberal support of western Christians have borne fruit for which the Church in China will ever be grateful. But what we call pioneer work is only one aspect of Christian work, which is both many-sided and eternal. When one great rock is opened we find several staring defiantly at us. Although the rocks of ignorance, superstition, prejudice and sin seem to be impenetrable, the power of God is overcoming them slowly and surely.

Training of Leaders The author is emboldened to express his opinion about "What should be the present contribution of missions to Christian work in China", as follows:— Better training of leaders in all lines of Christian work, especially in educational, medical and evangelistic work. The impetus of the New Thought Movement is carrying with it all the educated people in China, including the students. The rationalistic attitude of many has become a skeptical attitude. The ancient reverence for the scholar is transformed into the modern thirst for truth and reality. Nothing is taken for granted. Past traditions are mercilessly uprooted and reexamined. The Christian religion with its various forms of Christian

work is not accepted on its face value. Under such circumstances, anything short of a vital religious experience, a thorough understanding of the past and the present of the Christian religion, and a modern attitude towards the methods and the policies of Christian work, the efforts of the Christian workers will fall far short of meeting the present needs of Christian propaganda in China.

This becomes the more urgent when one considers the widespread spiritual and moral movements. In fact all the new movements are partially ethical in nature, for example the New Culture Movement, the Feminist Movement, popular education, labor agitation. These all emphasize equality, democracy, service, justice etc. Even the anti-Christian movement is based on the "failure" of Christianity during the world war. The new Confucian, Buddhist and eclectic movements are not started to compete with the Christian movement. But they are a sign of the self-consciousness of the religious minds of China who want to express their faith in works. We need to convert the saints and devotees of China. If it were not for some of the poor, weak, short-sighted and self-important Christian workers, many a Nicodemus and Joseph of Arimathea would have openly confessed Christ. Thus we need better trained men, larger men and deeper men.

This suggests a more thorough and modern education in all the missionary schools, especially a more liberal theological education, and the opening of more schools for women. But higher education alone cannot turn out more consecrated lives. Only bigger and deeper missionaries will stimulate the production of more consecrated native workers. God forbid that we should rest satisfied with the evangelization of China; with better trained and more consecrated leaders we must also Christianize China.

The average citizen or business man in China, owning the traditional local or patriarchal government, is more concerned with his city or village life than the national life. In meeting a person from another province, municipal or provincial pride usually exceeds national pride. During these years of national humiliation and political

chaos the press and the seriously minded are re-*emphasizing* the importance of local government and municipal life. The social aspects of the Christian religion constitute a new appeal, and when demonstrated in institutional work it is a resistless appeal to the practical man and to the so-called middle and lower classes of the nation.

Capital and Labor Among the more modern minds of China the struggles between capital and labor, the economic life of the workers, labor unions, factory laws, etc., are live topics of discussion. It is most opportune for the Christian workers to preach the social gospel of brotherhood and coöperative service. When the disturbed state of the country settles down in a decade or two, we shall find machinery usurping manual labor. Judging from the industrial experience of the West if the Christian Church cannot create a public opinion for justice and service now, it will be very much more difficult to do so later on.

The Indigenous Church It should be understood that "indigenous" does not mean "anti-foreign". It means the giving of the best in China to Christ even as the Magi presented their gold, incense and myrrh. It is St. Paul's policy of being all things to all men in order to save some. It is the fulfilment of the New Testament prophecy that all the nations and kings of the earth will bring their glory to the heavenly Jerusalem. It is the saying of Keshab Chandar Sen, founder of the Brahmo-Samaj, that never would India surrender to Christ so long as the Savior of the white races appeared before her peoples in European dress. (p. 3, "Other Sheep", by Harold Begbie). It means the contribution of the best Chinese Christian thought and national genius to the Church Catholic, and it is a presentation of Christ to the Chinese nation in Chinese form, language, and attire. The word "indigenous" seems to have special odium for some missionaries, but it should be frankly asked if the Roman, Greek, and Protestant interpretations of the facts of the Christian revelation are final, and if their forms of church organization are adaptable to the whole human

race? In other words can the Abundant Life of Christ be shared only through the denominational churches of the West?

**Conditions of
an Indigenous
Church**

To foster an indigenous church, these are some of the conditions:— (a) The native ministry should be enlightened, being equipped with the best intellectual and theological training; it should be unfettered, and given its sphere of work in which experiment is countenanced; it should be entrusted with whatever the missionary is entrusted with, taking it for granted that it is well-trained and worthy. (b) There should be greater denominational coöperation and mutual understanding. Ecclesiastical competition and denominational investment should fade before the vision of the Church Catholic in China, which is the aim and end of missionary endeavor. (c) The Chinese clergy and responsible laity should be given equal footing in church matters with the missionaries, for example in the making of budgets, and the expenditure of appropriations. To sum up, mission work and mission policy should be church-centric, not mission-centric. True accountability is not primarily to the feelings of the pious financial supporters of the West but to the spiritual well-being of the local Christians as well as to the practical efficiency of the local churches.

When the writer suggests these three immediate tasks of more consecrated and better trained leaders, a socialized Christian work, and an unhindered development of an indigenous church, he hopes he is not understood to be depreciating missionaries and their work. For what more can we expect than generous support and devoted effort? But when stress is laid on these tasks, it might be worth while to delay some of the expanding work, so that the Christian enterprise may be put on the most advantageous basis, and mission policy have the right perspective. What I mean is that a greater proportion of the available funds might be used in the training of workers than formerly. God grant that East and West shall both be humbled before the altar of a common humanity and

shall work for the redemption of the same by means of a Catholic Church. Let the feelings of racial superiority and ultra-nationalism be melted into a warm zeal for a common citizenship in the Kingdom of God. Then and only then will mission work approach to the fulfilling of the Great Commission of our Lord and Savior, Jesus Christ.

CHAPTER XL

RECENT CHANGES IN MISSION ORGANIZATION

James Maxon Yard

It is perfectly evident that great changes are taking place very rapidly in the relation between the missions and the growing Chinese Church. In fact, one of the major problems of missionary work of our day is this matter of adjustment between the missionary and his board on the one hand, and the Chinese Church on the other.

Chinese Control All missions are at work on this problem; some with much more success than others. Some missions seem not yet to have sensed the rising tide of nationalism in China and the demand on the part of the Chinese for a large share of control, even in such matters as finance and the question of whether or not missionaries should be returned to the field. Other missions, however, like the North China Mission of the American Board, and the Methodist Episcopal Church, have gone pretty far in turning over authority to the Chinese.

Sino-Anglo Committees Joint committees, one-half appointed by the mission and the other half by the Chinese Church, are becoming more and more common and are apparently meeting with a great deal of success. This article deals only with the relation of the missions to the churches and does not deal with the question of the relation of Chinese to educational institutions, hospitals or industrial enterprises.

Chinese Financial Responsibility In my correspondence in preparing for this article I have noticed two movements that have been very prominent during 1923. One, the tendency to put more financial responsibility on the Chinese, giving them control over all funds except those for missionary salaries; and two, the tendency to unite the different denominations.

It is difficult to say just what has occurred during the year just passed, for many movements have been under way for several years, some of which have just come to fruition during the past year and others which have been completed in previous years are only now beginning to prove their value.

Union in South China In South China the Presbyterians, Congregationalists, and the United Brethren, have been organically united for five years. This union is called the Church of Christ in China, and these bodies hope to form a national union. Dr. Fisher says, "Practically all the offices of the Church of Christ in China are being filled by the Chinese. The executive, consisting of eleven, has two foreigners on it. There is one general secretary, (Chinese) and one foreign associate secretary serving at the request of the Chinese."

Union in North China In North China the Kung Li Hui has two general secretaries, one foreign and one Chinese who has recently taken up his office. This new organization of the churches under the American Board is making great progress and is most successful.

A correspondent says that "progress is being made toward complete organic union with the independent, undenominational Chinese churches and with the churches of the London Missionary Society group at the same time. We missionaries do not feel like pushing too hard on any of these movements, though, without exception, we desire them. I think a new and larger union will be consummated within different sections of our group within a year or two."

Anglican Missions There has not been much change in any of the Anglican missions during the past few years. The Chinese have very little relation to the foreign funds. In many cases these foreign funds are entirely at the disposal of the bishop. Aside from the question of funds the Chinese have a large share in the administration of the church. The authority in the Chung Hua Sheng Kung Hui is diocesan. In most cases the bishop and some of the clergy happen to be English, but as all agree, that is a temporary matter.

The Church of Scotland Foreign Mission has during the last two years been organized into a presbytery in connection with the Church of Christ in China, and the presbytery of Ichang is part of the synod of Hupeh. As indicated above the Church of Christ in China is perfectly autonomous. It exercises full discipline over its ministers and evangelists apart from any foreign control whatsoever.

In Szechwan the China Inland Mission, West, has recognized during the past year for the first time "a group of pastors" with full status and responsibilities.

Chinese Control of Church The Canadian Methodist Mission has gone forward during the past year in its policy of handing over control to the Chinese Church. "Until recently the rule has been for all estimates, whether for church work or for other departments, to be made by the Council (foreign). If there is any increase in special lines, for example, salaries for preachers, the Annual Conference (Chinese) made a recommendation to the Council, and the latter if it deemed wise passed on the recommendation to the Home Board. Recently, however, in response to the recommendation of the Annual Council, the Home Board has agreed to give us lump sums for the different departments of work, and in the case of that for church work the lump sum is given directly to the Annual Conference. Beginning with this year the church work estimates are to come up through district meetings to the Conference, and then the latter is to apportion the Home Board grant among the districts. This will mean that in the future the Council will have only an advisory relation in regard to the expenditure by the Conference of the money granted directly to it by the Home Board."

The president of the Canadian Methodist Conference is now a Chinese, and this year for the first time all the ten districts have Chinese as chairmen. These district chairmen have general oversight of the work on the district and a heavy share of responsibility to see that the funds are properly used and also to see that local funds are collected.

Union of
Methodists,
Presbyterians
and Congrega-
tionalists

Because of the union of the Methodist Church of Canada with the Presbyterians and Congregationalists there is a movement to unite those same churches in China. On the other hand "there is a desire on the part of some in Szechwan to see a union of the bodies — that can unite — here in West China. I see no reason why we might not have at least a federation of four or five of our West China churches."

The Wesleyan bodies report no particular change in the relation between the churches and the missions but there is a tendency to place much more responsibility upon the local churches.

Forward
Movement in
Christian
Mission

There is a very interesting forward movement in the United Christian Missionary Society, which organization is almost completed. "In 1921 it was appointed by the convention to draft a new form of mission government which should admit the Chinese to fuller participation and responsibility in the mission government. The report of this committee was adopted in the convention of the present year, April 1923. According to this report, which was submitted in the form of a tentative constitution of administrative responsibility, authority will rest without distinction on the Chinese Church which will include both the Chinese Christians and the missionaries. They will meet annually in a representative convention for fellowship, to hear reports of the work, and to make recommendations of policy to the administrative body (to be called the Joint Council).

"The Joint Council will consist of sixteen members, one-half foreign, and one-half Chinese. This will meet twice yearly, but will not consider details but rather determine policies and will instruct the administrative committee. This Joint Council is to have supreme authority including the control of funds and the calling and recalling of missionaries."

"The administrative committee will function continuously throughout the year. It will consist of three foreigners and three Chinese. It will meet as frequently as

necessary, perhaps monthly, and will be responsible directly for all details of administration."

Methodist
Episcopal
Mission

The Methodist Episcopal Mission has continued during the past year to give financial authority to the Chinese Church. The All-China Finance Committee, which is made up of delegates from all the conferences, is half Chinese. In every one of the eight different missions the finance committee is one-half Chinese. These committees deal with all funds except those pertaining strictly to missionary salary, and personal matters.

At the Central Conference for Eastern Asia held at Foochow in November, 1923, the Board of Foreign Missions was asked to sanction the formation of an Executive Board which will be at least half Chinese and which will have authority over all matters such as education, including religious education, medicine, finance, evangelism and publicity.

The Central Conference also petitioned the General Conference for power to nominate its own bishops beginning 1928 (not stating whether these bishops should be Chinese or foreign).

In all the above nothing startling appears: no revolutionary tendencies are evident, but it is perfectly clear that the Chinese Church is developing and that in most cases missionary societies are willing to hand over full authority to the Church. There is sometimes difficulty in the matter of the relationship with the home boards in the matter of property and funds. It seems to be more difficult for secretaries at home to relinquish authority than for the missionaries on the field.

CHAPTER XLI

THE MISSIONARY SUPPLY FROM NORTH AMERICA

Burton St. John

For the North American Missionary Societies to secure each year the right men and women to respond to the calls from the various mission fields, is a worthy task. In numbers, it is not stupendous. To keep up the present supply of missionaries requires only about twelve or fourteen hundred new men and women each year. The remainder of the so-called Christian world normally would be asked to supply no greater number.

To the Demand Judged by the present trend in mission policy it seems not at all likely that the demand upon the young life of North America for their part of the world task should ever exceed two thousand a year. Even at that maximum it requires annually only one out of seventeen or eighteen thousand of the membership of our churches.

Variation in Standards of Requirements Reckoned in another way, however, the task is far less simple than it would appear from a statistical pre-view. The fact is that there are still a good many worthy missionary societies which do not have a rigid standard of requirements for service abroad. There are many others which have high ideals as to training but no adequate plan for the selection and placement of the persons they need to staff their foreign missions. For these reasons, if the churches in North America are to supply the type and number of missionary candidates needed there must be a marked reshaping not only of the standards of requirements by many societies, but also by a majority of the societies a radical change in the methods by which these societies discover and select their candidates.

**Records of
Student
Volunteer
Movement**

Without doubt the records of the Student Volunteer Movement furnish the best single source for the study of the problem of supply in missionary personnel from North America.

Contrary to the supposition of a good many, the membership of the Student Volunteer Movement does not supply even a majority of all missionaries going out from North America. However if one excepts the wives of missionaries, it might be said with assurance that seventy-five per cent of the college trained people who are commissioned to service abroad under the various mission boards are recorded members of the Movement.

Possibly a parenthesis is not out of place here. A hurried but not casual study was made of the personnel reported in the China Directory of Missions by several missionary societies of varied doctrinal points of view and varied emphasis on methods of work. This indicated that the members of the Student Volunteer Movement, among those recently arrived, are in the minority. In every instance after ten or more years of missionary service the members of the Movement are in the majority.

**Supply and
Demand**

In 1922 the missionary societies generally reported an adequate number of satisfactorily trained people applying for service abroad.

In 1923 there has been no evidence of a change in this situation. With a very few exceptions appointments were made up to the limits of the funds of the societies.

Two years earlier when the societies were sending out the record number of new missionaries this was not the case.

This increased number of calls for new missionaries in 1920 and 1921 came at a time when the normal supply was low. It takes from three to six years to mature a "missionary candidate crop." The war years were lean years.

The situation at the present time shows an approximately satisfactory supply of missionary candidates. To be sure it is a time of decreased income for the missionary societies as compared with the years 1920 and 1921. It also is the time at which students who volunteered in the years 1918 to 1920 are coming to readiness for

appointment. We are now seeing the fruitage in offerings of life of the denominational missionary revivals and the Inter-Church World Movement. This fact is evident also in the phenomenal developments of the Student Volunteer Movement during the past quadrennium.

The question is often asked "Where are these candidates coming from?" It is a fair assumption that they come from the same sources as do the membership in the Student Volunteer Movement.

Age of Volunteering A study of the reports sent in by new volunteers indicates several interesting facts. First: the age of volunteering centers around the nineteenth and twentieth years and around the freshman and sophomore years in college. This is exactly what would be expected by any careful student of the situation.

In short the upper classmen and the graduate students furnish only a small minority of volunteers. Nor is there any patent evidence that this smaller fraction, these more mature students, actually yields a larger percentage of new missionaries. An established purpose at the normal age of decision clearly tends to permanency of purpose.

Source of Supply The Societies therefore that depend upon a recruiting program that includes only the theological and other graduate schools, are sure to complain of great *difficulty* in securing candidates. For these the dearth of applicants will continue until there is a new policy which meets students on their own ground. It is not difficult to capitalize this early decision period, for students are unusually responsive to missionary society cultivation.

Nor should one overlook the fact that this is not entirely the result of training received in the first two years of college. Far from it. In fact at the present this student responsiveness is due less to influences in college than it was during the generation just passed. There is not the slightest doubt that the wider study of missions in the home, in the Sunday school, the young people's societies and from the pulpit has profoundly influenced

the thinking of students now in college. It is not stirring addresses by great student leaders, but information and thoughtful guidance which are helping the student to decide to give his life to foreign service.

Synchronizing with this change in initial influences has come a change in the region which produces the missionary supply. The most productive area in the United States at the present time seems clearly to be the Mississippi Valley. This is not entirely due to the fact that the proportion of the population who attend college in the Middle West is increasing more rapidly than in the Eastern states. There is something in the attitude of life and possibly in the educational principles which tend to give the middle Westerner a more outstanding desire for world contacts and world thinking. This fundamental fact of student religious life has its clear counterpart as well in commercial and industrial enterprises.

Something similar to this is occurring in Canada, though of that it is more difficult to speak with assurance. Doubtless, considering the fewer number of students, Winnipeg rather than Toronto would lead as the initial source of the Canadian missionary supply.

Type of Mind Nor is it the under-staffed and under-equipped small college of the West that is producing these missionaries. A careful study seems to show clearly that the type of mind which is most open to the challenge of service abroad is the one which seeks training in the best equipped institutions available.

I am well aware that the records of certain societies belie this statement. For an explanation of this fact one should look for the cause somewhere outside student life.

While the middle West clearly leads as the region of initial production, one finds that these young people in large numbers seek graduate study in the more famous Eastern institutions. This is quite in keeping with what one understands to be the temper of this generation of religiously minded students.

If, therefore, we are to see to it that there shall be a continuous flow of missionary candidates of first grade, we must strengthen those foundations of the Christian life and of world information which lie back in the home and

in the early church influences. It must become wholesome and natural for the finest of our youth to decide for the missionary vocation and to do so at the normal age. The church through its missionary societies or through some other appointed agency must be alert to counsel with these young people after the decision and until the actual appointment. The church which follows such a plan will lack neither numbers nor quality in her missionary supply

CHAPTER XLII

THE METHODIST CENTENARY MOVEMENT

James Maxon Yard

Beginning The missionary work of the Methodist Episcopal Church in America began in 1819. The Centenary Movement which was authorized by the General Conference of the Methodist Episcopal Church of 1916 and by the authorities of the Methodist Episcopal Church South was a union enterprise. It was a union of the two churches and also a union of Home and Foreign Missions.

Surveys One of the first things the Methodist Episcopal Church did in preparing for the Centenary was to order a complete world-wide survey. In every mission field of the Church committees came together and surveyed the need and their responsibility. They wrote out a careful estimate of the men and money needed during the period of 1919-1924.

These surveys were then sent to the board in New York where a staff of men all through the summer of 1917 studied these reports and prepared them through charts and maps and reports for presentation to a committee of a hundred which met at Niagara Falls in September 1917 under the chairmanship of Dr. John R. Mott.

Centenary Committee That committee, composed of bishops, ministers and laymen from all parts of the church, studied the facts and asked the Boards of Missions to go forward with a campaign adequate to fill the needs as revealed by the surveys. The initial call was for G\$80,000,000 which on account of the war emergency and the inclusion of the askings of certain allied church boards was increased to G\$105,000,000.

Inauguration in China At the close of the campaign in America the Bishops for China, who had been especially enthusiastic about the whole enterprise, asked that a man be sent to China to study the whole field and

inaugurate a great forward movement here. Dr. Ralph A. Ward was appointed to the work.

He gathered a number of Chinese and missionaries who travelled with him and Bishop Lewis, from conference to conference, studying the whole situation and seeing the needs and opportunity of each place right on the ground. They all arrived finally at Peking where they spent three weeks in January and February of 1920 going over their findings and mapping out the China Centenary Movement.

**China
Program
Committee**

An executive committee of twenty-one, three from each conference, was appointed to carry out the program. That committee met in September 1920 and appointed Mr. Paul

Hutchinson Executive Secretary of the Movement. He, as soon as possible, established the Department of Evangelism with Dr. W. P. Chen as secretary, the Department of Literature under Dr. R. Y. Lo, a Department of Graphs and Statistics under Mr. J. I. Parker, a Photographic Department under Mr. R. M. Vanderburgh, and a Lantern Slide and Coloring Department under Miss L. Douglass.

Methods

A great deal of literature and helps on stewardship and prayer have been produced and widely distributed.

Evangelistic campaigns have been conducted in all of our conferences and in most of our large cities.

The Department of Graphs made an intimate study of some of our fields and produced maps and charts for use both in America and China.

The Department of Photographs and Lantern Slides has gone steadily forward until now we have on file more than 7,000 negatives coming from all parts of China and representing all types of work. That department is now serving people in nearly all the missions of China. Miss Douglass trained a corps of Chinese girls who have now taken over the coloring work and they are producing very excellent colored slides.

We have produced twenty lectures which have been distributed to all of our conferences. Every one of our mission stations has been equipped with a lantern.

The Executive Secretary has given much time to work in middle schools and colleges. In 1922-1923 he visited

Foochow, Peking, Tientsin and Nanking, and held meetings for students. He also gave time to evangelistic campaigns in the churches in various cities.

Future Work The years of special celebration are about at an end but much of this promotional work will go steadily forward. Our Literature Department has been greatly stimulated. A method of evangelism has been discovered and also there has been discovered the special need of training church members. Lantern lectures will continue to be produced for use in all our conferences. A Department of Publicity has been established which aims to keep in touch with our constituency in America through articles in the church papers and directly through letters and leaflets.

The Centenary office in Shanghai now has a mailing list of 50,000 including all pastors of Methodist Episcopal Churches in America. This list has grown rapidly in the last few months. More than 150,000 letters and leaflets were mailed to contributors in the United States last year.

Aims Thus the China Centenary Movement has two aims, one to stimulate the Church in China, the other to furnish information to the Church in America.

Mr. Hutchinson went home on furlough in 1921 and Miss Helen Griffiths became Associate Executive Secretary and carried on the work until May 1922 when James M. Yard was appointed Executive Secretary. In addition to the things mentioned above his duty was to promote the celebration of the 75th Anniversary of the founding of Methodist Missions in China.

Forward Movements The anniversary caused a strong forward movement in every conference, special emphasis being placed upon the call to life service and the campaign for funds for the local jubilee project. The year has been most successful. Hundreds of students have pledged themselves to Christian service and every conference has more than reached its financial goal, e.g. in Central China the goal was \$7,000 to be raised in two years. At the close of the first year they have received in cash almost \$6,000. This money is to be used by the Chinese Church in opening work in Anking.

CHAPTER XLIII

THE MISSIONARY SITUATION IN GREAT BRITAIN

Nelson Bitton

Five years after the close of war the conditions of life in Great Britain in every section of the community remain unsettled. In the years 1919 and 1920 the immediate reaction from war gave promise of a better state of things, particularly in the life of the Churches. This brought into being an optimism later unfulfilled. The burden of extra service taken in the years of war was maintained by many for the two years following, and the return of many Christian and other highminded men and women to everyday life and work, made available an extra measure of enthusiasm for goodness and truth. The war activity, however, passed, and as the workers grew tired causes that had seemed to flourish in an unparalleled way through the years 1919 and 1920 began to fail. There were no dramatic signs of collapse, but a general weariness. The promise of politicians made in the heat of war-gratitude that there should come a new earth, and that Britain must be made a land "fit for heroes to live in" became a gibe on the lips of the disappointed. The sense of political failure made its influence felt in other spheres of life. The inability to establish effectively the work of the League of Nations reflected a failure of idealism on the part of the superficially minded and became in turn the cause of a moral and spiritual pessimism in others. The Church of Jesus Christ which had seemed to promise so much at the close of war went back both in its own grip of the world situation and in the expectation of the general public.

The disorganization of Church life which began in part during war when so many hundreds of thousands of Christian men were withdrawn from their Church service, is still evident.

The generation that took an active part in war, and which in ordinary circumstances should now be the mainstay of the life of the churches is to a large extent not to be found within them. It is upon the generation that was too young for war that a great deal of the burden of Sunday School and similar activities is being placed.

These younger people are possibly responding with greater zeal and efficiency to the religious needs of the time than any recent generation. Their strength for the main service of the Church is, however, not yet equal to their spirit.

The lack of candidates for ministerial and missionary service is one of the results of the spiritual disorganization caused by war. From all the Churches, without exception, comes the cry of half filled theological and other training colleges, and a lack of response on the part of the men, particularly those who are now at the age of 25 or thereabouts and would normally have been taking up the active service of the Church.

One of the notable difficulties realized by missionary societies up to the present time has been the failure to secure trained medical men for posts in the mission field. In spite of the loyal coöperation and active service of the workers of the Student Christian Movement, there are notable gaps in British medical missionary service still needing to be filled.

The pressure of family claims upon the life of young people in the home land has also borne adversely upon the candidate. The call of pleasure and the demand for a comfortable life as some compensation for the rigours of war service have also been evident, and the comparative poverty attached to the service in the Church has been set in all the greater contrast by the excesses of widespread profiteering. The standards of life and the cost of living have heightened far in excess of the ability of churches and missions to keep pace with them. The call to Christian service both at home and abroad is more than ever a call to sacrificial life.

The problems of Church Finance have in consequence of the higher cost of living weighed perhaps more heavily in recent years upon the Christian community than for a

lifetime past. Efforts have been made to secure from the supporters of Christian movements a proportional increase in giving in order that the Church might meet without loss the new situation. Unfortunately in the absence of a widespread spiritual awakening the mass of the supporters of the churches have not been in a position to advance their gifts in adequate proportion; the result has been to place a greater hardship upon the workers of the Churches than upon almost any other section of the community. The result has been a harassed Church and an unceasing stream of special appeals which have partly diverted the thought of Christian leaders from the programme for evangelistic advance which all agree to be the outstanding need of the time.

Those who have made considerable profits in recent years are not in any measure found within the ranks of organized church life. The *nouveaux riches* are not particularly susceptible to the ideals of religion. The fact that so little of organized Christian effort has wholly failed, whilst at the same time a number of new causes are being sustained, shews that the standards of giving in Christian circles, whilst falling far short of the ideal, has nevertheless been well maintained.

The problem of unemployment cannot leave the Christian Church untouched. In days of wide commercial depression the unemployed are not, as is sometimes suggested, always unemployable. Steady Christian men and women who have never known the indignity of receiving support from public funds have had to join the ranks of the dole-recipients, or face for themselves and their families homelessness and starvation. The year 1923 marked the highest point of unemployment ever known in Great Britain, and that at a time when the cost of household commodities and of general home expenditure remained at seventy per cent above pre-war figures.

It is in the face of such conditions that the church has had to supply as best it could the clamant needs of the world which seeks Christ. The confused international political situation has added to the difficulties of the home situation. The unsolved problems of Europe touch more closely the heart and life of Great Britain than any other

country in the world. The amenities of life in Great Britain depend upon the stable conditions in Europe and in the world at large. Staple trades, iron, steel, cotton and the like have been almost in chaos as a consequence of the unsettlement of Europe, the destruction of German credit, and the vagaries of currency in other lands. This has begotten a sense of insecurity and a fear of the future which have increased the difficulties of Christian service and propaganda. Many well-to-do Christian men with large and old established business in their hands are dreading the events of to-morrow and are praying and working for European peace. Their minds are not free to deal with the world situation from the point of view of the Gospel, although events have been teaching them in unmistakable clarity the world's need of peace. There are not wanting people who feel that the whole strength of the Christian Church ought, for the time, to be brought to bear upon a peaceful solution of the troubles of Europe, and the application of the Gospel and its message to the urgent needs of the Western World.

The conflict between divergent schools of biblical interpretation and theological thought has also handicapped in some measure the forward movement of missions. The revolt of the ultra-orthodox school of thought within the Christian Church against the extravagances of the hyper-modernists has in certain instances caused difficulty in missionary circles. Practically, all the great missionary societies have been subjected to charges of looseness in their control of their missionary workers, whilst charges in some instances have been definitely made against the personnel of headquarters' staffs and membership of Committees.

In a time when unity in missionary effort is proceeding along a steady and inspiring course of progress, the appearance of new lines of cleavage between Christian workers is singularly unfortunate. A few extremists at either end of the Christian churches can cause a great deal of difficulty, and, by their reckless activity, hold back the steady advance of the whole body.

The coöperative enterprises of the missionary societies have been more marked than ever. Under the general

direction of the Conference of British Missionary Societies working from Edinburgh House the Home Base Committee of the Conference has carried through a most successful united Campaign in the district of Colchester in Essex. The campaign affected the whole life of this important East Anglian city. Plans have been made for a similar campaign in a large midland industrial center and Leicester will be the scene of a similar effort in 1924. The Protestant Churches of Ireland have planned a united missionary campaign effort for Dublin in 1924.

United efforts in the direction of missionary films and the steady development of the most effective coöperative work of the United Council for Missionary Education are other features of successful coöperative activity.

Through the agency of the Press Bureau the secular as well as the religious press has been regularly supplied with items of missionary interest and the attention of the general public been drawn thereby to outstanding aspects of missionary endeavor.

The year 1923 has shewn a widening interest in the work of missions; in official life there has been noted a growing appreciation of educational and social service rendered by missionaries to the peoples of the world. Notably in Africa the problem of education has been recognized as having its focus in missionary policy, and there has been a growing acknowledgment of the place occupied by missions in the uplift of African life.

The growth of intellectual interest in the aims and methods of Christian Missions is notable in student circles.

In the decision of the British Government to remit the remaining portion of the Boxer Indemnity to China for the purpose of mutual benefit to China and Great Britain, there has again been a generous acknowledgment of the place taken by Christian Missions in China.

The educational world is recognizing that the record of missionary endeavour is a worthy theme for teachers, and education departments have approved of the use of missionary lessons in school textbooks as contributing to the teaching of biography, history, and geography. Much has been done to capture the thought of school life for Christian

missionary service. Three societies have joined hands in the publication of a terminal paper for public school boys.

The meeting of the International Missionary Council held in Oxford in the summer of 1923 brought a strong delegation from the United States and Canada and enabled the Anglo-Saxon representation of Christian Missions to take further counsel with the delegates from the Continent of Europe. The proceedings of this body have been circulated to the mission boards and a detailed account of its proceedings has appeared in the International Review of missions.

Undoubtedly there was not only a considerable advance made in the understanding of coöperative missionary policy during these meetings, but the deepening of international spiritual fellowship was manifest and the decision to attempt a Universal Day of Prayer for Missions, which is being carried through successfully in most of the countries concerned, was the mark of a big spiritual advance.

In conclusion it may be said that a considerable and unmeasured development of missionary endeavor through the Churches of Great Britain awaits only the coming of a deep spiritual revival. Most of the requisite machinery is here. Within our churches also there is to be found the personality required for the human fulfillment of the Divine Will. The kindling of the soul of the Church by the breath of the Holy Spirit of God would bring a greater day of Pentecost to the Christian life of this country for the service of the world of men.

CHAPTER XLIV

ROMAN CATHOLIC MISSIONS IN CHINA*

Eliza L. Roots

The 1919 statistics of the Roman Catholic Missions in China report 1,971,189 Christians, meaning by this baptized persons, whether adults or children. In reporting the year's baptisms, however, 47 of the 50 dioceses reported 48,849 adults baptized and 41,662 children of Christians. Besides these, 12 dioceses reported 52,735 "enfants de païens à l'article de la mort" and the others 101,838 "enfants de païens." Some of these last possibly included children of the orphanages for foundlings and children purchased by the faithful as a philanthropic act.

Other statistics are even harder to glean from the reports of the several dioceses, since there is no one form used by all. Diocesan boundaries sometimes overrun those of a given province and most provinces contain several "vicariates," as the dioceses are more commonly called. Chihli has six and Shensi five, but Kiangsu and Anhwei are united to form the diocese of Kiangnan. Macao as a diocese is related to the Patriarchate of Goa and not to any authority in China. The 50 dioceses are themselves grouped into five Regions. Workers and Christians, though all known as "Catholics" and all subject, through their clergy, to the Pope, are closely associated with the various Religious Orders to which they owe their Christian origin. The Lazarists, for instance, in 11 Missions, care for 606,425; the Jesuits, in 2 Missions for 358,301; the Franciscans, in 10 Missions, for 279,644. While the Chinese priests, numbering 942, are also Lazarists, Dominicans, etc. There are also secular priests, both Chinese and foreign, and

* (Based on the 1921 edition of "Les Missions de Chine et du Japon," by J. M. Planchet, of the Lazarist Mission, Peking. 1923 edition exhausted.)

professed sisters and lay brothers of many different Orders, as well as Chinese catechists, male and female; but detailed figures for all these are lacking.

One finds several interesting articles in the second part of the book. Some letters written by missionaries in different fields: — one from Chihli about the famine; one telling the story of the German Missionaries during the War, who seem to have been received, during internment or travel, with all Christian hospitality by their fellow Roman Catholics of French and Italian nationality. And there is an interesting story of work in Kansu by a missionary who apparently has both apostolic zeal and a saving sense of humor. There is an article on "Protestantism in China" which reports such movements, here and in the world at large, as had made friendly overtures to the Roman Church, tells of evangelistic activity at the Peking Union Medical College, and gives certain statistics of the Non-Roman churches. There are also Notes on political events in the Far East and a list of Chinese notables who are Roman Catholics.

But the article which seems to us to be of the greatest interest to our readers is the twenty pages devoted to an account of Chinese Religious Societies of lay men and women; not of those Orders brought from abroad who admit Chinese to membership, but of societies purely Chinese both in personnel and dress and governed for the most part by themselves. 17 of the Societies for women are described in some detail as well as the only three for men which exist at present.

In these Societies both men and women take certain vows, though not necessarily all those which mark the monastic system, and live under a rule more or less regular according to circumstances. Sometimes — and this seems to have been the way most of the earlier societies started — the sisters remain living in their own homes as any single women might do, working under the direction of the priest of the parish. Again, they are sent out from a Mother House by a Superior whom they have had their share in electing, returning thither from time to time for retreats and to enjoy the companionship of their fellows. Always there seems to have been a preliminary training in a

novitiate, longer or shorter according to the work in prospect and to the previous education of the candidates. As to this last, the faces shown in the group pictures are those of women of at least average intelligence, while that of the Superior of the "Sisters of the Heart of Mary," of the Diocese of North Manchuria, shows a face distinctly strong and thoughtful in character. She has held this position, by the way, for twenty years, having been annually re-elected by her companions during all the time. This particular Order has two centres of residence, and the missionary of each place is the Director of that centre. But there is only one Mother House, where novices are trained and from which the Superior administers the entire organization of 105 members. Of these, 26 were novices and 34 were living in community at the time of writing, while 45 were on the field at work in the different villages.

Of the labors of this Society the writer of the report says, — "Besides the work of baptizing the children of non-Christians at the point of death, they taught the Truths of our sacred Religion to 1318 children in the girls' schools committed to their charge." And he adds, "They are our most valued auxiliary, our devoted co-workers. As for the Christian communities, the zeal of these sisters in the teaching of children and catechumens and their devotion to the sick are often the most substantial support of our popularity in those stations where the missionary can visit only three or four times a year." In the case of this sisterhood the novitiate is of three years, after which they don the black veil which, with the crucifix hanging about their necks, seems the only thing about their dress to distinguish them from ordinary Chinese women of quiet habits and small means. The vows then taken are renewed every year when they come in to the Mother House for Retreat. Their object is stated to be two-fold, — to work out their own salvation as servants of God in a state of virginity, and to help the clergy to extend the reign of God in the souls committed to their charge. At the other extreme of organization we have the following from a writer in East Honan: — "This little Vicariate of about 350 square kilometres is scarce more than in its beginnings, being barely five years old. Up to the present we have

been unable, on account of lack of resources, to found in the cities either schools for the education of the leisure class or charitable institutions. Our whole efforts have been turned upon the country, where the attitude of the people is generally most sympathetic and welcoming. . . . The pearl of our Vicariate is the district of L.—, . . . there we have a large group of single women living in their own families and devoting themselves with much zeal to the education of catechumens.”

There are other interesting articles in the book. Attention is especially called to this one with the thought that in it may possibly be found some suggestions for the use in our own missions of Christian women of limited education, especially in country districts; this, as well as an opportunity for the better understanding of the methods and spirit of our brethren of the Roman Communion.

PART VII
EDUCATION AND STUDENTS
CHAPTER XLV

GROWTH OF UNIFICATION IN EDUCATION

Donald Roberts

Unification in education may be viewed from two phases: on the one hand in the development of union institutions; and on the other in the formulation of common standards and a common policy.

An instance of actual achievement in unification of organization is to be seen in the removal of the Peking Women's Medical College to Tsinanfu, to become a joint enterprise with the medical school of Shantung Christian University. Similarly, Peking University and Shantung Christian University united in the summer of 1923 in holding a summer session for teachers and religious and social workers, and the same plan is to be followed for the present year. In Central China one of the most noteworthy developments, is the agreement already made by the American Church Mission, the Yale Mission, and the Wesleyan Missionary Society, toward the establishment of an institution to be known as the Central China University. It is proposed that the plan go into effect in 1924, "to carry on a tentative coöperation in the College of Arts and Sciences for a period of three years upon the grounds of Boone University." Each of the participating missions "will maintain a college unit consisting of a certain number of professors and a hostel or hostels sufficient to house the students connected with that unit." The government and discipline of each collegiate unit is to be under the direction of the mission concerned, but the university faculty is to have full charge of the scholastic discipline, each college being free to give such additional

instruction as it may desire. This plan, which suggests Oxford, is a very concrete outcome of the recommendation of the Educational Commission of a Christian university for Central China. It does not involve the transfer of the Medical school of the College of Yale in China, that school being continued in Changsha.

Union Medical School—East China In East China there is the same trend, and the establishment of a union medical school seems nearer actual realization than at any previous time. The American Church Mission offers to loan "the dormitories, lecture rooms, laboratories and other facilities of St. John's University for the use of the school, and the St. Luke's and St. Elizabeth's Hospitals for the clinical work of the school." The proposal is that "until such time as other means of support are obtained, St. John's University offers to be responsible for the running expenses of the school, with the exception of the support and housing of the members of faculty appointed by other members of the union, and of the rental of a dormitory in town. This offer includes the purchase of necessary apparatus and materials." Coöperation on the part of the Northern Baptist Mission is virtually assured.

The invitation of Soochow University to the other institutions of East China to participate in the maintenance of the Comparative Law School on a recognized union basis is another instance of the tendency of which we are speaking. Here, too, favorable action has already been taken by missions on the field. Another union experiment last summer was the holding of a summer school of the East China Christian Colleges at Shanghai College, and it is planned to hold the school again in 1924, at St. John's University. The school is intended to offer a wide choice of courses of college character for middle school teachers and for religious and social workers. The use of the summer vacation for institutes and summer sessions for various purposes is increasing and it is significant that the enterprise is in almost every case union rather than individual.

**Teacher
Training**

The question of teacher training has been taken up in East China still more definitely, and plans have been drawn up and accepted by three missions for the establishment of a permanent Christian normal school. The Northern Baptist Mission has offered its school plant at Huchow, and the Presbyterian Mission has been asked to release a member of its staff to become principal. The standard proposed is that of a senior middle school; the instruction to be in Chinese; and the course to cover at least two and if possible three years. It is intended that the school be opened in September 1925.

**Unification
Growing**

Enough has been said to indicate that union enterprise, especially in the consolidation of schools for specialized training, has received an increased impetus in all parts of China. Unification in education is however growing in still other ways than those mentioned, and is to be seen in the adoption of common standards and a common policy, through exchange of opinion on the part of those interested in school and college administration and through the effort of missions to bring their institutions into conformity with the recommendations of the Educational Commission. Reorganization is taking place, for example in a number of the regional and provincial educational associations; and the Advisory Council of the China Christian Educational Association at its annual meeting on May 8-9, 1923 urged upon the provincial associations as their first objective the securing of full-time secretaries—certain associations having already made this step. With few exceptions missions are bringing about a reorganization of their schools to accord with the 6:6:4 system recommended by the Educational Commission. Questions as to the curriculum, textbooks, standardized tests, and supervision have received increased attention and discussion. Colleges have taken up consideration of requirements for admission, of the college budget, of policy in regard to athletics, and through consultation and informal agreement have benefited each by the others' experience. The reorganized Association of Christian Colleges and Universities moreover

held an important Conference at Ginling College, Nanking, on February 5-7, 1924.

Viewing the changes that are taking place one is more than ever convinced that the visit made by the Educational Commission and the publication of its report were two events of inestimable value to Christian education in China.

CHAPTER XLVI
GOVERNMENT RELATIONSHIPS AND
CHRISTIAN EDUCATION

Earl Herbert Cressy

During the last few years, in spite of political uncertainty and national turmoil, the number of students in government schools has been doubled. A few years ago mission schools were the outstanding examples of modern education. To-day, progressive mission educators are coming to think of the place which Christian education should occupy in a larger whole.

Perhaps the first official recognition of this situation was the appointment in 1919 of a Committee on Government Recognition of Mission Schools by the East China Educational Association, following a paper presented by Mr. H. S. Redfern.

This Committee was instructed to study the situation and report upon the desirability of seeking for government recognition. At the annual meeting in 1920, the Committee reported that in its judgment the advantages would outweigh any disadvantages, provided always that the Christian character of the schools be not abridged in any way. This policy has been adhered to up to the present time.

During the year that followed, regulations were put forth by the Ministry of Education for the registration or chartering of Christian higher educational institutions. These regulations imposed no restrictions with regard to religious teaching or exercises. The University of Nanking made application and the Department of Agriculture was recognized by the government.

In consequence of this situation, the Minister of Education, Mr. Fan Yuen Lien, made it known that he would accept an invitation to address one or more

of the Christian Educational Associations. The Committee on Government Recognition extended an invitation to him to address the East China Christian Educational Association in January 1921. The Minister himself was unable to come but sent Dr. H. C. Zen, the highest official next to the Minister in the Department of Education. Later the Minister himself addressed the Chihli-Shansi Christian Educational Association.

The friendly attitude taken by the Ministry of Education at this time is evident from the following quotations, the first and last being from the address of Mr. Feng and the other from that of Mr. Zen:—

“Gradually the Chinese public changed its doubtful attitude and became interested in the work done by Christians. Therefore, the revolution which took place all over China was partly due to the influence of the schools and colleges established by Christians.

“After travelling all over the United States and investigating into the reasons for her prosperity, I have come to associate Christianity with the conditions which I found there.”

“But recently the whole nation has been awakened to the necessity of modern education, and schools of all kinds have been gradually established. This condition, this similarity of aim, has enabled the Chinese people to sympathize with the organizers of the educators in mission schools. They have changed their attitude of indifference to one of hopefulness, their policy of *laissez faire* to one of coöperation.”

“I hope you will be more intimate with the Chinese government. I hope that you will be more intimate with local educational circles. Education in China is still young, and educators have not had large experience, but when you are doing a thing, it does not matter whether your standard is high or low, if you can coöperate together and help each other. I hope you will be able to adjust this misunderstanding which the Chinese have hitherto had toward Christian people.”

Earlier in the year, in view of the development of interest on the part of the Ministry of Education, the

Committee on Government Recognition of Mission Schools of the East China Christian Educational Association came to the conclusion that all relationships with the central government should be handled by a Committee of the China Christian Educational Association rather than by a committee of one of the regional associations.

It seemed to the Committee on Government Recognition of Mission Schools that this question should also be discussed, and through the good offices of Dr. P. W. Kuo, President of the Southeastern University, and Dr. W. T. Tao, now Secretary of the National Association for the Advancement of Education, a conference was arranged in Peking, at which three of the most distinguished educators in China, Fan Yuen Lien, Yuan Shi Tao and Yen Hsiu, all of whom were former Ministers of Education, were present in addition to Dr. W. T. Tao, Dr. Chang Po-ling, Dr. T. T. Lew, Dr. Paul Monroe, Dr. Leighton Stuart and the writer. Prof. Burton was unable to attend on account of illness.

On behalf of the Committee on Government Recognition of Mission Schools, a statement was made to the effect that this problem of relationships was for the first time being faced by Christian education in China, and the new National Committee had requested this conference with a view to securing the advice of distinguished Chinese educators as to the best method of procedure. An afternoon was given to discussion. The chief difficulty on the part of government educators seems to be that of compulsory religious exercises and Bible study. Even on this point they were ready to consider making some concessions. On the other hand, members of the Committee pointed out that schools established by churches could not eliminate the religious element without cutting off their income. It was pointed out that the very purpose and existence of the whole system of Christian education was bound up with the emphasis on religion.

As a result of close relationships between government and Christian educators in the city of Hangchow, where the writer was then located, he was one of the two official delegates from the province of Chekiang to the conference called to hear the report of Dr. Paul Monroe. The fact of a foreigner being present in this capacity aroused a great

deal of interest, and it so happened that a number of those who had been in the conference above referred to, were on the committee for drafting the constitution for the new Association for the Advancement of Education, which was organized as a result of Dr. Monroe's visit. It occurred to them that it would be well to make this association an opportunity for coöperation between government and Christian educators. Membership in the Association was, therefore, thrown open to Christian institutions and educators, and several Christian educators were among the charter members. A number of Christian colleges and universities, many Christian educators, and the East China Christian Educational Association have since become members of the National Association for the Advancement of Education.

This has resulted in very real coöperation along a number of lines. In the report of the work of Prof. McCall and those associated with him, precisely one-third of the educational tests listed bore the name either of a Chinese faculty member in a Christian institution or of a missionary educator, in some cases as the sole author of the test and in other cases as one associated in its making.

In following up the work of Dr. McCall and his associates, the National Association for the Advancement of Education asked Prof. E. L. Terman of Peking University to take charge of the national survey.

The work, over a period of two years, of Dr. George R. Twiss has resulted in a plan to create a National Science Board, and the conference of Christian Colleges and Universities, recently held at Nanking, voted to accept the invitation of the National Association for the Advancement of Education to coöperate in such a board.

The value of such coöperation is not merely in what is accomplished, but it serves a useful purpose if it helps to remind Christian educators in China that the work which they are doing is part of a larger whole, and that Christian education should do more than establish its own system, and has a great opportunity to exert its influence upon the future of education in China.

Mission schools can learn from Government educators, as well as make a contribution to government education.

CHAPTER XLVII

THE PRESENT SITUATION IN RELIGIOUS EDUCATION

William L. Sanders

Introduction The writer of this paper is greatly indebted to the following persons who have graciously replied to inquiries concerning the present situation in religious education: Miss Marjorie Rankin; Professors T. C. Chao, B. Burgoyne Chapman, James B. Webster, E. L. Ford, Alexander Baxter; Rev. E. H. Cressy, Rev. James M. Yard, Rev. A. D. Heininger and Dr. Frank Rawlinson.

Perhaps the most important factor in religious education is the personality of the teacher. This paper does not attempt to touch that factor. Rather the technical side is stressed, and especially as it applies to the primary and middle schools.

The Situation The first thing to be said about the present situation is that it is unsatisfactory. This is not the opinion of one man. Go where you will in China, the same answer is forthcoming . . . we are not achieving desired results. The lack of a well-defined aim; the chaotic state of the curricula; the unscientific methods in use; a dead formalism, the very antithesis of a spiritual awareness; poor teaching of the Bible; the attempt to do more than can be done well: these are some of the reasons assigned for the superficiality of much of our work. The situation is strikingly put by professor T. C. Chao, of Soochow University: "We are putting foreign caps on our Chinese boys and girls . . . too few trained Chinese teachers of religion . . . our Bible teachers teach like parrots . . . too few trained Bible teachers in our middle schools . . . too many schools teach nothing but Old Testament ethics, which make our young people unfit to live in modern

society . . . there is not the right kind of religious atmosphere . . . there are too few outlets for the religious enthusiasms of the students . . . the compulsory nature of many religious activities tends to kill true religion and place in its stead a kind of hypocrisy . . . the inability on our part to meet the Renaissance Movement because we do not know what is going on in the religious thinking of the Chinese to-day . . . a general conception on the part of the students that courses in religious education are something they must submit to if they are to get an education in a Christian school . . . we do not touch the families behind the students and their home environment, which are actually undoing our work . . . we do not follow up the religious education started in the school."

Miss Marjorie Rankin, of Weihsien, Shantung, writes: "How much religion is taught in the day schools depends entirely on what one's definition of religion is. Through our section of Shantung religious education in the lower primary schools is almost entirely formal. The children memorize the catechism but they memorize it as they do their national readers without knowing the meaning. We have advanced from memorizing chapter and verses of the Bible to memorizing Bible stories. But except for a very exceptional teacher it is still a simple feat of memory. This is by no means the ideal of the leaders but it is all the teachers know and can do. The Bible is always read in morning exercises and all are able to get up and pray extemporaneously, even to the wee tots. These outward forms are insisted on and carried out most scrupulously in all schools. But my personal observation would lead me to think that they are mere forms — the husk of religion with very little life."

One result of this situation is admirably summarized by Mr. B. Burgoyne Chapman, Principal of the Central China Teachers' College, Wuchang: "What seems to be nothing else than a rooted idea which it seems almost impossible to remove, is that the Bible being "holy" is not intelligible, and can not be understood or explained intelligently. Students are ready to answer any questions that have a holy or sacred sound about them, with such

words as 'commit sin,' 'repent,' 'believe in Jesus,' 'Babylon,' 'taken captive,' 'received the Holy Spirit,' 'preach the Gospel,' 'the Grace of God:' any one of these answers may be given to any question one asks about the Bible. Boys who are capable of thinking well on other things seem to be incapable of thinking intelligently about the Bible . . . the teaching of Scripture in our lower schools and even in our middle schools, must be incredibly bad. And inspection confirms this deduction from results."

Curricula

The survey of courses compiled by the Rev. A. D. Heininger, of Tehchow, Shantung, covering eighteen middle schools in north and central China, reveals how unbalanced and how really chaotic the religious education curricula of many of our schools are. For instance, the schools reporting show a total of eighty-five courses in religious education. In thirty-two of these the Bible is used as a text with a variety of helps. Of the remaining fifty-three courses but one book was used as many as five times. Thirty-three books were used but once. Not only is there a variety of books in use but there is evidently a lack of sequence and balance in the courses offered. Some begin with the Old Testament; others with the New Testament; and still others with something about one or both of these books. In speaking of these courses, Mr. Heininger says: "They seem to be quite largely informational. When we compare them with good religious education courses for high school age in America, they seem dry and uninteresting."

That these courses are not satisfactory is shown by the widespread feeling that materials should be prepared for and adapted to the use with Chinese students; that, is, there is a growing demand for indigenous material. Professor E. L. Ford, of the Anglo-Chinese College, Foochow, writes: "It seems to me an anomaly that Protestant Christianity though it been in China a hundred years, has yet failed to get out textbooks to teach Chinese young people the truths of Christianity. Texts in English, in science and the various other subjects required in the schools have been prepared, many of them by missionaries, but China still lacks a coördinated and correlated series of textbooks for

use either in the Sunday School or in the curriculum work." Perhaps this is due, in the words of the Rev. E. H. Cressy, Secretary of the East China Christian Education Association, "to the disposition on the part of the various missions to carry on religious education each according to its own denominational point of view . . . an attitude in sharp contrast to that toward all other subjects where there is a universally admitted necessity of getting together and securing uniform curricula, textbooks and methods."

Very little has been done in correlating the work of the Sunday School with the week-day curriculum. Some oppose any attempt to do this on the ground that within a limited time the mission schools will have to go out of business owing to the growing number and efficiency of the government schools. Where coördination has been tried, as in the University of Nanking, a happy solution of the problem of slovenly work in the Sunday School has been found.

The increasing number of Christian children enrolled in government schools calls for the development, in connection with the churches, of a system of week-day schools of religion. The Christian forces are just beginning to face this problem.

Methods

The lack of aim; the shortage of trained teachers; the lack of knowledge of the pupils' needs and of organized material with which to meet them: all contribute to our unscientific methods. There is no clearly defined understanding of the relative importance of the pupils' needs and the material to be used in his religious education. This is frequently demonstrated in the misuse of the problem-project method. We begin with material and attempt to create problems, which are often not problems at all for the pupil. The method thus misused makes artificial work inevitable.

Professor James B. Webster, of Shanghai College, says that "the defect is more deep-seated than the matter of method, though that is entirely unscientific. For my own work, I have decided to stop trying to work on the improvement of curriculum based on subject-matter and to begin with the fundamental life-needs of the pupil. So

much of the traditional matter as meets these life-needs I shall introduce and not be concerned about the rest. In this way we may help the Chinese to build up an indigenous system of moral and religious education."

The Outlook Happily some attempts are being made by responsible bodies to remedy the defects in our present situation. The growing awareness of weakness in this field gives promise to the efforts of the following organizations:

(1) THE NATIONAL CHRISTIAN COUNCIL, through its sub-committee on Religious Education, is attacking the problem by bringing together the various groups and interests that they may face squarely the situation and, as one body of Christian workers, do something more constructive.

(2) THE CHRISTIAN EDUCATIONAL ASSOCIATION, through its new Associate Secretary, Dr. E. W. Wallace, is at work on the problem of curricula.

(3) THE YOUNG MEN'S AND YOUNG WOMEN'S CHRISTIAN ASSOCIATIONS are making a distinct contribution through their voluntary Bible Study Courses in which thousands enroll annually. These courses are being enlarged and improved. Perhaps the most significant step for the religious education of illiterates is being taken by the Y. M. C. A. through its "One Thousand Character Course".

(4) THE KULING SUMMER SCHOOL OF RELIGIOUS EDUCATION, an interdenominational body, is seeking to promote a larger understanding of the issues and their solution by lectures and courses of study. The wide representation at the 1923 session evidenced a new interest on the part of the various denominations in the problem.

(5) THE CHINA SUNDAY SCHOOL UNION'S activities are summarized in its own report in another part of this volume. (See section "Coöperative Movements in China" Chapter xxviii, page 191)

CHAPTER XLVIII

SCIENCE EDUCATION IN CHINA

George R. Twiss

Since June 30, 1922 the writer, assisted by Western trained Chinese educators as coöbservers and interpreters, has visited 21 cities in ten provinces in North, Central and Western China, and observed teaching practices and equipment for science teaching in 187 schools and colleges.

**Inadequate
Equipment** With the exception of three or four middle schools and a few of the universities and colleges, the science equipment was found to be very inadequate, consisting almost exclusively of demonstration apparatus without adequate facilities for individual laboratory practice by students. Much of the apparatus on hand is of such poor construction or in such bad condition that it cannot be used: much is also obsolete. Relatively few of the teachers in the middle and primary normal schools use effectively the apparatus that they have. Most of these equipments were purchased when the schools were established from 10 to 20 years ago, and little or nothing has been added to them since. With a few exceptions these statements apply equally well to missionary middle schools. Hence, in general, in missionary colleges the first courses in science are of middle school grade, as judged by Western standards.

**Adequate
Equipment** Among the government and provincial institutions that have adequate modern science equipment and modern classrooms and laboratories designed and maintained according to first class standards, are Tsinghua College, Peking, and the Middle School of the National Southeastern University in Nanking. The Peking National University, The Peking National Normal College, Pei Yang University (Tientsin), Nan Yang University (Shanghai), the National Southeastern University (Nanking) and the First Kiangsu Middle School

(Nanking) are representative older institutions whose equipments are being brought up to modern standards, but whose buildings do not embody all the advantages of modern design.

Among the privately maintained institutions, Peking Union Medical College, Peking University, Nankai College (Tientsin), Shantung Christian University, Shanghai College, St. John's University, Soochow University, Hangechow College, Nanking University and Ginling Woman's College (Nanking), and Griffith John College (Hankow) all have modern equipment and good buildings, designed according to modern requirements either completed and occupied or in process of construction. With these examples easily accessible for inspection, and with their experience available for advice, mistakes in construction and equipment that have been made in the past, may easily be avoided by the managers of other institutions who are planning expansion of their building or equipments. Every new building and every new equipment outfit should thus become better than its predecessors in point of efficiency and economy. The recent disastrous fire at Southeastern University in which the equipment for physics and biology, a part of that for chemistry, and the greater part of the library were destroyed, should make evident to every educational administrator the folly of placing valuable equipments in non-fire-proof buildings.

**Chinese
Teachers**

The Chinese teachers of the middle schools, normal schools and colleges compare favorably with those to be found in similar ranks anywhere in point of native intelligence, personality, enthusiasm for teaching, sympathetic attitude toward their pupils, and open-mindedness toward the possibilities of improving their methods of instruction. All these essentials they possess to an admirable degree; all but a very small percentage of them, however, lack knowledge of the science of teaching and skill in the art of teaching. Most of the college teachers have had good training in experimental science, but little or none in education, and they lack the long experience which has enabled their older colleagues to acquire skill in the processes of science teaching. Nearly all of the middle and normal school teachers lack adequate

knowledge of their sciences, lack skill in experimenting and in the use of the scientific method, and are not informed on the fundamental principles of science teaching. Consequently, not because of any fault of their own, but because of radical defects in their training for their work, the great majority of the science teachers in China are not teaching in such a way as to infect their students with enthusiasm for science and scientific or technical pursuits, or to develop their latent abilities for applying the scientific method of problem solving to the problems of their daily life and conduct. Their own training has been almost exclusively of the formal bookish type, without practice in experimenting or inductive reasoning or scientific problem solving; and they are teaching as they were taught. It is true, as they complain, that they are handicapped by lack of proper apparatus especially such as the students can use for individual practice in experimenting; but the fundamental difficulty is that they lack the knowledge of how to construct or purchase such apparatus, how it is to be used and kept in workable condition and how it may be repaired if it becomes slightly damaged. Given a trained and resourceful teacher, and he will succeed in gradually acquiring and building up the outfit of equipment which he needs for effective instruction.

In Middle Schools

In the schools of middle grade with very few exceptions the teaching consists almost exclusively of formal lectures in which the ground covered is practically identical with that in the textbooks. The students listen passively and usually take no notes. Occasionally the lecture is really interesting and inspiring in content, is illustrated by rapid and skillful blackboard drawing, and also by experiments or by specimens, models or charts. Sometimes but not often, the teacher is careful that every student shall observe the details of the concrete illustrations that he is showing, and asks some questions both for the purpose of fixing attention and of testing comprehension as he proceeds. Such excellent technic in lecture instruction, however, is rarely found in the middle schools, and is by no means frequent in the colleges. Chinese is the medium of instruction in

the middle schools as a rule, and English prevails in the science instruction in the colleges.

In Class Work In all types of schools, and especially in the government institutions, recitations and class discussions are very infrequent. Blackboard demonstrations, topical recitations, and supplementary readings and reports are rarely, if ever, required. Questions are relatively few and receive short memoriter or factual answers coming from a small proportion of the students. Occasionally one hears a thought question which usually is directed to the whole class indefinitely, and is answered in a volley of confused sounds from a few individuals in various parts of the room. The answers given are short and simple, and of course no one hears any one of them distinctly. Memory questions can be used advantageously in rapid concert drills; contrariwise thought questions must be deliberately presented, a few moments' pause must be made so each individual may think out his answer, and then individuals must be called on in turn to present their answers and defend them by argument or explanation.

Defects Ordinarily even when questions are asked, they are sporadic and inconsequential. There is no attempt, through questioning, to probe ideas, to stimulate and direct thinking, to start an orderly, critical discussion, or to bring laggards into action, as should be the case. Among all the classroom exercises observed, a few outstanding exceptions were noted, in which the entire technic and procedure were really excellent, and in which the students were responding with enthusiasm, showing real self-activity, and thorough preparation. Such classroom teaching, now so very rare, might become common if there were available to the science teachers abundant opportunities to supplement the defects in their training by summer and extension courses in the content of their subjects and the proper methods of teaching them. Such courses should give special attention to methods of experimenting and of conducting laboratory teaching.

Laboratory Work Individual student laboratory experimentation is carried on in many colleges but is attempted in only a few middle and normal schools. In the majority of these when attempted it is not

thoroughly nor skillfully supervised, and is very imperfectly and perfunctorily done. The hope for any marked improvement of the equipment and teaching of science in the schools lies with the higher institutions whose professors of science have received long and thorough scientific training, and have made some study of methods, under Western influences and with background of Western educational thought, but who also comprehend Chinese conditions. Will the colleges in China and the colleges in America in which future Chinese teachers of science are being trained awake to their great opportunity of service to China, and undertake a rational and effective program for the proper training of science teachers both prospective and in service?

CHAPTER XLIX

THE MOVEMENT FOR THE SCIENTIFIC MEASUREMENT OF EDUCATION IN CHINA

T. T. Lew

One of the most hopeful signs of educational progress in China is the organization of the National Association for the Advancement of Education which came into existence by the amalgamation of several non-official educational organizations as the result of Dr. Paul Monroe's visit to China in 1921. This Association is getting the support of all the progressive elements of the country, under the able leadership of Mr. W. T. Tao, its general secretary. He is a Christian, a graduate of a Christian college in China and took post-graduate work in the University of Illinois, and Columbia. After several successful years in a Government University in China he was unanimously called to this office by the charter members of the organization. Among one of the numerous progressive activities aggressively carried out, is the Movement for Tests and Measurements in China. In 1922 Dr. William A. McCall of Columbia was invited, under the auspices of the Association, to come to China to be the director of Psychological research.

**Work of Dr.
McCall**

Dr. McCall spent the first half year in the South, choosing Nanking as the center for his work. In the second half year he made his headquarters in Peking. Practically all the men and women who had been trained in tests and measurements abroad were mobilized to work as a national committee. There are nearly thirty members of the committee scattered over all the important centers of educational activity in China. These people, under the leadership of Dr. McCall successfully carried out a very ambitious program in which was included the construction for China of educational

measuring instruments: the making of related educational projects: the writing of several books on measurement: the training of a group of college and university students to assist the various members of the committee in carrying out the construction of tests: and finally, a national survey with the use of some of these tests. The results of the work were surprisingly good. There were produced ten different kinds of intelligence tests, in seventeen different forms; and thirty-two educational tests in fifty-five different forms (some of these tests have different forms but belong to the same type); fifteen different projects that are related to scientific study and measurement of education such as standardization of measurement and statistical terminology; accumulative record card for standard tests; a slide rule for converting the Chinese old to the Chinese new age; a school building score card; and so forth; eight different books, elementary and advanced, on measurements and scientific study of education; and a national survey; all these were included in the original plan, and almost all were completed by the spring of 1924.

Workers

In this work the Christian educational workers have taken active and important parts. Among the thirty members of the committee there were eleven missionary educators and several other Chinese who are members of the faculties of Christian colleges and universities. The China Christian Educational Association had a Committee on Standardized Tests, and in the Annual Conference of 1923, the following members were appointed to the committee:—T. T. Lew, Peking University, chairman: Prof. S. G. Brinkley, Soochow University: Miss Alice Butler, Ginling College: Dr. Herman Liu, Y. M. C. A. Shanghai: Dr. L. S. Loh, Shanghai Baptist College: Mr. J. N. Keys, Canton Christian College: Dr. A. H. Bullock, Union Normal School, Wuchang: Mr. Ralph C. Wells, Point Breeze Academy, Weihsien: Prof. E. L. Terman, Peking University: Prof. C. W. Luh, Southeastern University, Nanking: and Prof. H. C. Cheng, Southeastern University, Nanking. All these members were actively engaged in the construction of the tests, or the related projects during the year.

**Summer
Institute**

During the summer of 1923 the National Association for the Advancement of Education conducted a Summer Institute of Educational Measurement. Over three hundred people from 13 different provinces, among whom were over eighty principals of well-known elementary and middle schools and a number of local educational commissioners or secretaries, attended. The business management of the Summer Institute was under the charge of Dean L. C. Cha of the Peking National Normal University. The instruction was given by Dr. Wm. A. McCall, the Director of Psychological Research of the Association, and T. T. Lew of Peking University. As a part of the laboratory work of the Institute, a Survey was made of Western Hill's Orphanage, the famous orphanage which is under the superintendence of Ex-Premier Hsiung Hsi Ling. The orphanage has over one thousand children, and the survey proved to be of real value to the whole movement.

Training Class

During the spring of 1923, while Dr. McCall was supervising the work in North China with Peking as its center, a training class for measurements was organized by T. T. Lew composed of students from three government universities and Peking University. McCall and Lew gave the general lectures to the class as a whole, Professors Y. C. Chang, L. C. Cha, Y. G. Ch'en and C. Y. Chang, of the Government Normal University, and Professor E. L. Terman of Peking University took part of the sectional training in building tests.

**National
Survey**

Among the many projects of the year was the plan for a National Survey with two general tests. These two national survey tests were prepared by Terman and Cha. When Dr. McCall's year of service was over he was urgently needed at Columbia, and when efforts to secure an extension of his leave of absence failed the National Association for the Advancement of Education asked Dr. McCall to suggest a man to succeed him in carrying on the work and to conduct the National Survey. Terman was chosen. Negotiations then followed between the National Association and Peking University to secure Terman's service. President J. Leighton Stuart of Peking University and Professor Galt, Head of the

Department of Education, heartily endorsed the plan and granted Terman a year's leave of absence to conduct the survey.

The committee on standardized tests of the China Christian Educational Association realized the importance of this National Survey and its bearing upon Christian education, and started negotiations with the China Association for the Advancement of Education to make the survey a joint affair. The value to Christian education of such coöperation lies in this; that in addition to other advantages the Christian Educational Association obtained a set of all the data secured in the survey. With the coöperation of Dr. Frank D. Gamewell, secretary of the Christian Educational Association, a conference was called by the committee at Kuling in August, at which meeting the following resolutions were passed:—

1. That the China Christian Educational Association coöperate in every way possible with the Chinese National Association for the Advancement of Education in the survey of schools to be held soon.

2. That since Professor E. L. Terman of Peking University has been appointed by the National Association for the Advancement of Education to direct the National Survey, we ask him to represent us as well in conducting the survey.

3. That mission schools in each center be surveyed at the same time as the government schools.

4. That we approve the temporary plans for conducting the Survey, which are as follows:

Plans for
Survey

a. That an organizing committee of five members for each large center be appointed. That this committee be made up of both government and mission school representatives.

b. That this committee coöperate with the Director of the Survey in organizing a group of advanced students (students in education where possible) in advance of the date when the survey is scheduled to be held in that center. That this group consist of from 50 to 100 students chosen from both

Government and Mission schools, and be large enough to survey the large center and the surrounding smaller centers in a reasonably short space of time.

c. That on the date when the survey is scheduled to begin the Director shall call a meeting of all principals, supervisors and such teachers as may care to come to put before them the detailed plans of the Survey.

d. That this meeting be immediately followed by meetings of the organized group of examiners, in which they receive special training in every step of conducting the survey. A maximum of three days may be spent on this preparation.

e. That the Survey be then conducted by this group of examiners under the supervision of the local committee and the Director.

f. That all the data from each class, school and school system be tabulated in duplicate, one copy to remain for the guidance of the principals and teachers in improving the teaching of the pupils and one copy to be filed with the Chinese National Association for the Advancement of Education.

g. That the National Association for the Advancement of Education be permitted to make an appropriate summary of all the data filed with it, and to publish this summary together with proper interpretations and comparisons for the information of the educators of China or others who may be interested.

h. That the National Association for the Advancement of Education be allowed permanent possession of the rest of the Survey in order that the test forms may be improved and that such systems of education may be made as the following: regional differences in intelligence and educational status; sex differences in intelligence; and educational status of different types of schools, etc., etc.

Accumulative Record System 5. That all mission educators be urged to acquaint themselves with the new accumulative record system for pupils now being prepared under the auspices of the National Association for

the Advancement of Education. This new system may be used with standard tests or with ordinary examinations.

Practice Tests 6. That all educators be urged to adopt the new practice tests as the most efficient known method for teaching pupils in grades 4 to 7, the four fundamentals in integers and decimals.

Mental, Moral, Physical Tests 7. That all educators be urged to acquaint themselves with the entire list of mental, moral and physical tests, which have been or are shortly to be published under the auspices of the National Association for the Advancement of Education and that these tests be made use of as fully as practicable for teaching and supervision in accordance with the suggestions given in the manual that accompanies each type of test and in a book to be published in Chinese now being prepared by Dr. Wm. A. McCall and Dr. T. T. Lew.

8. That mission educators be urged to continue their present generous support of the efforts being made by the National Association for the Advancement of Education to develop educational standards and to apply modern scientific procedure to the improvement of educational efficiency in all schools.

9. That the China Christian Educational Association expresses deep appreciation to Peking (Yenching) University for its generosity in lending Professor E. L. Terman to direct the work of the National Survey. We are deeply indebted not only to Yenching, but also to Professor Terman for his willingness to undertake this large and important task.

10. That the Association through its secretary thanks Dr. Wm. A. McCall for the aid that he has given to the committee and thus to the entire Association by his counsel and advice in the meetings of the committee.

And that the committee thanks the National Association for the Advancement of Education for paying his expenses to Kuling to make it possible for him to participate in the meetings of the committee.

Survey Schedule The final schedule of the National Educational Survey was approved by the directors of the National Association for the Advancement of Education, the committee on Standardized

Tests of the National Christian Educational Association, and by the leading educators in both government and mission schools. During a period of seven months it was conducted in the following centers:— Peking and environs, Tientsin, Tsinan and environs; Tehchow, Taian, Nanking and environs; Wuhu, Shanghai and environs; Soochow, Hangchow, Foochow and environs; Amoy, Canton and environs; Hongkong, Nanchang and environs; Kiukiang, Wuchang and environs; Changsha, Hankow, Hanyang, Paotingfu and environs; Taiyuan, Sian, Kaifeng, Moukden.

The Survey was organized and carried out according to the following scheme:—

1. A provincial organizing committee of five members for each capital city was appointed. The Chinese Secretary and the English Secretary for each committee were appointed by W. T. Tao, Director of the N. A. A. E. and Director of the Survey. A third member was appointed by the Provincial Commissioner of Education and two others might be appointed by these if necessary.

2. This committee coöperated with the Director of the Survey in organizing a group of advanced students (students of education where possible) in advance of the date when the survey was to be held in that center. This group of examiners consisted of from 50 to 100 persons.

3. On the date when the Survey was scheduled to begin, the Director called a meeting of all the principals, supervisors and such teachers as cared to come, to put before them the details of the plan for the survey.

4. This meeting was immediately followed by the meetings of the organized group of examiners, in which they received special training in every step of conducting the survey. A maximum of three days was spent on this preparation.

5. The survey of the capital city was then conducted by the group of examiners under the supervision of the Director and the local committee.

6. All the data from each class, school and school system were tabulated in duplicate, one copy for the guidance of the principal and teachers in improving the teaching of the pupils, and one copy being filed with the N. A. A. E.

7. The cost of each city survey test materials was borne by the individual schools or by the city as a whole.

8. Special duties of each local committee were as follows:—

a. Arrangements with the local city educational authorities for the survey of all schools.

b. The filling out the sheet of information about these schools. This list was then sent to the Director as soon as possible.

c. Arrangements for a room of sufficient size for the meetings of the examiners.

d. Collection for the test materials used.

e. Arrangement with outlying centers which want to coöperate in the Survey to send principals or advanced students to join the group of examiners for training.

**Survey
Director**

Professor Terman and his assistant Mr. Yang Chi Tsung (B.A. '23, Peking University) started in the work in September, and by March of 1924 they had trained, according to the process outlined above, over a thousand people to administer tests. They have tested over one hundred and fifteen thousand students, of whom about ten thousand were middle school students. About one third of the total number of students tested were students in Christian schools. This survey covered twenty-four colleges and universities, fifteen of the largest and best middle schools and over six hundred important elementary schools.

**Survey
Expenses**

The expenses were shared by various parties concerned. The local expenses were borne by each survey center. The cost of the materials of the tests were paid by each individual school. The traveling expenses of Professor Terman and Mr. Yang were paid by the National Association for the Advancement of Education and Peking University; the latter also paid Professor Terman's salary during the survey.

The work was a success. It has aroused interest in the scientific study of education throughout the country. While the work is just beginning, and a great deal of care was

necessary to insure scientific accuracy, it has made a good beginning. The Survey was limited, but it was nevertheless the largest ever undertaken in China.

With the interest thus developed by the survey and with the follow up work done by a group of scientifically trained men in the departments of psychology and education in the National Southeastern University, the National Peking University and the National Peking Normal University, under the able leadership of such men as Doctors C. W. Luh, S. C. Liao, J. P. Chu, Professors H. C. Ch'en, T. Y. Yu and others in Peking institutions and in other centers, with an increasing number of students trained under them, the movement for educational measurement has a promising future which will yield valuable results to educational work in China. Thus far, the contribution to the movement on the part of Christian educational workers has been considerable. It is hoped that the authorities in Christian educational work will continue their interest and liberally support the movement in the future.

CHAPTER L

PRELIMINARY SUMMARY AND REPORT OF THE NATIONAL EDUCATIONAL SURVEY

E. L. Terman

Date of Survey We began the actual survey work in Peking according to schedule on the sixth of September (1923). The remaining three weeks of this month had been set aside for the survey in the capital city, and such foresight proved to be extremely wise.

Centers Visited We left Peking on the last day of September, (1924) and then visited twenty one centers, in which we delivered 35 lectures, some of which went toward the instruction and preparation of 1670 examiners, who tested in the centers visited 81,500 elementary and middle school pupils. These examiners have in several cases gone to outside centers and have with our techniques tested 10,000 more pupils, making a total of 104,000 pupils tested. Adding to this a possible 18,000 who are in scheduled centers at this date January (1924) still to be tested and in some centers not on the original schedule but who insist upon being included in the survey, we shall have a *grand total of 109,500* pupils tested.

Institutions Visited This includes work in and with 24 of China's colleges and universities, about 50 of her largest and best middle schools, and over 600 elementary schools, many of which were personally visited. About 2/3 of these were government and private schools, the other 1/3 mission schools. We have seen both government and mission schools dressed in their best clothes and doing very good work. We have seen them also dressed in very poor clothes and doing very poor work. Both government and mission schools were wide open everywhere for our work and no question asked anywhere was ever left unanswered. Below is a brief summary of what has already come out of it or of what will come out of it in the immediate future.

Nation-wide Interest The interest in scientific measurement in education is nation-wide. The following urgent appeal to come to Changsha is typical of the interest shown everywhere.

“The people here have certainly gotten busy. The Provincial Educational Association, the Commissioner of Education, and the Christian Educational Association have combined in inviting you to come. All the schools in the city have been notified and asked how many would like to have tests given. Also places near enough to get here readily have been invited to come. The Governor is being asked to contribute \$300.00 for running the local survey. (He did it and furnished us first class passage back to Wuchang besides.) So you see you will just have to come here next week.” Educators everywhere seem to be glad to find a substitute for personal subjective judgement in connection with the results of their work. They are anxious to measure the effects of the expenditure of their time and effort and money with objective scientific standards. This is necessary in every nation but in no nation more so than in China.

Coöperative Spirit

A second value of the Survey will be an enhanced national coöperative spirit that will produce better educational work. The Survey was welcomed first of all because it was a national coöperative project. All recognized that the more each center could put into it, the more the nation would be able to get out of it. It was perhaps the first national survey of education in the history of education and it was possible to carry it on only because of the unstinted coöperation of each center that had an opportunity to share in it. By coöperating in a national project many cities learned for the first time how to coöperate within their own walls. In many centers city educational associations were organized as a byproduct of the survey.

Setting Standards

Perhaps the largest single possibility that will come out of the Survey will be that of setting *national and regional standards* for all the various types of elementary schools that exist. Practically every city of any size has the provincial school, the hsien school, the model school, the normal department, school or

college attached practice school, the private school, the mission school, the boys' school, the girls' school and the coëducational school. From our data, which represent everyone of these types, it will be possible to fix standards with which any individual school of any type may compare themselves. Not the standardization of text-books and of methods but of *desirable goals* will be the aim. If present plans and recommendations work out this will be done not only for the elementary schools of the nation, but the Survey will also be a stepping stone to similar possibilities for *middle schools* and *colleges* as well.

A fourth possibility of the Survey is that it will help in the discovery of newer and bigger and more worthwhile goals in our elementary school work. As soon as we begin to measure, we begin to inquire into the quality and the worth of the thing that we are measuring. It is true that to-day for the most part we are only measuring the thing that we stress most in our schools—knowledge and skill. Scientific consideration is telling us that perhaps there are other things that are of even greater worth than these. Scientific measurement has revealed other goals in the form of habits, attitudes, ideals, interests and appreciations. We must find methods for attaining these more desirable goals in our schools, for soon science will test the efficiency of our schools by scientifically measuring them.

**Effect on
Children**

But the fifth and perhaps the most important of all values of the Survey will be what it will do for the individual children of China. Our schools exist not for the principals, the teachers, the parents, not for good looking plants, buildings or equipment—The schools exist for the CHILD. The CHILD is the center of all. All that we expend in time, effort and money is for him. Anything that we can do that we may better understand the children with whom we work is hailed with a warm welcome. This after all was the secret of the genuine interest in the Survey. The teachers who are working with the 109,500 children tested will know them as they have never known them before. Because they will know and understand them better, they will be able the better to *guide* them in making their best and fullest contribution to the social order in which they are soon to be the leaders.

A PRELIMINARY SUMMARY TABLE

	<i>Centers</i>	<i>Children tested.</i>	<i>Examiners trained.</i>
	Peking	7,000	50
	Tientsin	7,000	35
	Techow	500	25
	Tsinan	4,000	50
	Taian	500	25
	Nanking	7,000	100
	Soochow	5,000	150
	Shanghai	13,000	210
	Hangchow	4,000	200
	Foochow	7,000	175
	Amoy	3,000	100
	Hongkong	8,000	
	Canton	6,000	125
	Nanchang	2,000	70
	Kiukiang	500	15
	Wuchang		
	Hankow	4,500	100
	Hanyang		
	Changsha	5,000	240
	Kaifeng	2,000	100
	Paoting	2,000	100
	Taiyuan	1,500	100
	<hr/>	<hr/>	<hr/>
Total	21	81,500	1970
Outside centers tested	11	10,000	
Yet to test	10	18,000	
	<hr/>	<hr/>	<hr/>
Total	42	109,500	1970

CHAPTER LI

STUDENT VOCATIONAL INTERESTS

A. J. Bowen

The Chinese college student of to-day is in revolt against custom and tradition and against arbitrary authority imposed from without, even from parents, in reference to his life work, as well as in reference to his thought life. His best and most natural advisers, parents and teachers, are therefore, often ignored.

Change of Choices His vocational choices are thus both made difficult and more subject to frequent change.

His supposedly modern views create many difficulties for himself, and the present disorganized condition of society and government make the deciding of his career no easy task. Also lack of any adequate opportunities for vocational experience before student days are over, adds to his difficulties. Fancy plays a large part in shaping, at least, his earlier vocational interests.

Statistics Inadequate Adequate statistics for a study of the subject, either as relating to government or to missionary education, are difficult to obtain.

Two organizations, dealing chiefly with government education, are producing some valuable materials that yield data relative to this topic, The Society for the Study of International Education, and the The Chinese National Association for the Advancement of Education. The former has issued a valuable work very recently, "Education in China" and the latter has issued a series of eighteen pamphlets. For data relating to missionary institutions, we rely chiefly on published catalogues that also give occupations of alumni, on letters and reports of executive officers, and in one case on carefully analyzed records of a particularly efficient admissions' committee.

Institutions Studied We are considering the student vocational interests in the ordinary college and university.

We do not consider "vocational" or "occupational" schools, of which there are all too few, but happily,

a slowly increasing number, chiefly governmental. In the case of normal schools, teacher's colleges, Bible and theological schools, medical schools, law schools, agricultural and forestry schools, engineering and technical schools, the vocational interests are in general indicated by the number of students in each. Bulletin No. 16 of The Chinese National Association for the Advancement of Education (1923), gives the following results for the 34,880 students in all kinds of colleges and universities:

Statistics	<i>Type of Institution</i>	<i>No. of Institutions</i>	<i>No. of Students</i>	<i>Percentages</i>
University.....	35	13,098	... 37.4 %
Teacher's College.....	8	3,093	... 8.8 %
Agriculture	7	1,271	... 3.6 %
Technical	13	2,026	... 5.8 %
Commercial	8	1,890	... 5.4 %
Medical.....	7	832	... 2.4 %
Law	33	10,864	... 31.4 %
Others	14	1,806	... 5.2 %
	Total		125	34,880
				100.0 %

From "Education in China," it appears that 40% of the students in 14 government universities are studying law and political science, that is, are interested primarily in politics and government; 15% are interested in engineering; 9.1% in commerce and business; 3.6% in education; 1.7% in agriculture, and .002% only in medicine. The interests of 15,191 students in government "Special Schools" in 1921 show the same trend, namely, 61.2% in law and political science; 10.0% in engineering; 7.3% in commerce and 6.7% in medicine.

It would seem, therefore, from this rather meagre data that government university students are primarily interested in preparing for governmental and political positions. How far this interest is determined by patriotic motives for political reform and betterment, one cannot say, but theoretically, at least, judging by magazine articles and the general spirit of university students, one would think that this was a dominant motive. Scientific engineering is a new

interest in China, and here again, no doubt patriotic motives stir the interests of students to develop the natural resources and to increase the prosperity and prestige of their country. Specific school training for business and commerce is also a new interest of growing volume. Scientific or western medicine does not interest government students as much as one would expect. Probably its requirements are too exacting and expensive, its financial returns too precarious and its opportunities for patriotic and altruistic service too little appreciated. The interest of teaching, a calling which is more and more regarded as a profession and as an end in itself, for college grade men, is still too much regarded as a means, not now, it is true, to political position, but rather as opportunity to gain experience before going abroad, or if nothing better turns up, to a still honored position in society, even though not very well paid except for the favored few who teach in colleges.

Mission
Students

Turning now to mission higher education and taking the graduates of twelve colleges and universities, including one woman's college, we get the following very interesting data, which show not only theoretical interests, but what mission college graduates are actually doing.

<i>Type of Interest</i>	<i>No. of Graduates</i>	<i>Percentages</i>
Educational work.....	848	45.6
Business and industry ...	266	14.2
Ministry.....	241	13.0
Medicine	184	9.9
Social service	74	4.0
Government service.....	67	3.6
Office work	38	2.4
Agriculture and forestry...	31	1.7
Banking	29	1.5
Engineering	24	1.3
Literary work	21	1.1
Law and politics	17	.9
Journalism	11	.6
Research	3	.2
	1,854	100.0 %

While these figures do not include all of the Christian colleges or even all of the graduates of the twelve yet for those considered no doubt the data is fairly full and accurate, and the percentages may be relied upon.

Principal Interests It is significant that so large a percentage of our graduates become teachers, and this together with the character of the majority of these graduates helps to account for the strong and favorable standing of mission colleges. No doubt their influence would be still greater if these colleges had given them more technical and professional training for the task of teaching. It will surprise some of our friends and most of our critics to know that the third largest group of graduates are in the Christian ministry and the fourth in medical work. Eighty per cent of Christian College graduates are in work that the Church is primarily concerned with, namely, education, ministry, medicine and social service, largely the Y.M.C.A. The Christian schools are the only ones that definitely train men for altruistic service, and it is gratifying to know from actual figures that an encouraging number are giving their lives to non-gainful occupations. It is not without significance that the second largest group of graduates are entering business, for the majority of these men are Christians.

Vocational Interests We have the vocational interests of 49 students who graduate next June from one of the mission institutions. Of the 23 agricultural and forestry students, 22 are planning to engage in various forms of agricultural and forestry work, while one is planning to teach. Of 26 arts and science men, 16 are planning to teach; 5 to enter business or industry; 2 to enter the ministry; 2, office work; 1, literary work, and 1 to enter political life; about 40% are planning later to study abroad.

Occupations of Parents From this same institution we have the occupations of 631 parents or guardians of the same number of students seeking entrance into the University, who give their vocation plans as well as the courses chosen. It is interesting to note that 88.5% of these students recorded that they had on entering, occupational experience. Of course the vocational interests

here indicated are rather narrowly limited by the courses offered, and the aims and ideals of the institution.

<i>Occupation of Parents or Guardian</i>	<i>Vocational Plans of Students</i>
Business	30.5%..... 10.7 %
Teaching	30.5%..... 20.1 %
Politics or Govt. Service.....	13.9%..... 0.4 %
Farming	12.1%..... 12.4 %
Medicine	0.8%..... 1.6 %
Ministry	4.0%..... 8.2 %
Unmentioned or Uncertain.	3.6%..... 21.0 %
Artisan	3.0%..... 1.5 %
Military	0.8%..... 0.0 —
Engineering	0.8%..... 0.0 —
Study abroad	0.0%..... 24.1 %
100.0%	100.0 %

Courses Elected by These Students.

Arts and science	55.5%
Agriculture and Forestry	22.3%
Business	12.9%
Education	6.3%
Pre-medical	1.4%
Uncertain	1.6%
100.0%	

Here we have some limited data concerning student vocational interests as compared with their parents' occupations. In teaching, agriculture and the ministry, the percentages hold approximately the same. Less students seem interested in business and very few in politics, probably because there is considerable depression in both and too little to appeal to ideals at present. There seems to be more interest in mission schools in medicine than in government schools, though it is not so strong in either as health and social conditions warrant. Probably if we could get the data concerning a similar group of high school graduates entering college in America, we would find about the same percentage who had no very clear

**Student
Interest
and Parents'
Occupation**

life-work objective in mind at the beginning of their course. The very large percentage, making the most numerous of any one group, 24%, looking forward to study abroad, indicates a very strong and widespread interest of Chinese college students to-day, which one is inclined to think is not entirely desirable.

The interest in arts and science courses, 55.5%, outweighs all other interests, and the majority choosing these courses go into teaching and business, the ministry and social service.

Of 42 graduates during the past five years of one of the best mission woman's college, 33 have their interests and work in teaching; 4 in medicine; 1 in literary work; 1 in Y.W.C.A. work, and 3 in home economics having married. All 10 graduates of the class of 1923 went out as teachers.

In conclusion, this partial study of student vocational interests would seem to indicate that government students are primarily interested in politics and law, mission students are primarily interested in teaching and business, while the most dominant motive of all is patriotism and service.

CHAPTER LII

UNION COLLEGES FOR WOMEN

Matilda C. Thurston

Building Epoch The year 1923 marks a new stage in the life of the union colleges for women in China, India, and Japan which might be called the building epoch. Both Ginling and Yenching have been housed in Chinese buildings which have afforded fairly adequate accommodation for the work of the pioneer period, and picturesque backgrounds for the faculty and student life, but have not fully compensated for inconvenience and discomfort. The need for new buildings has been felt for several years and unsuccessful efforts were made in the spring of 1920, in connection with the inter-church campaign to get money in America. The women's colleges are not yet in a place to appeal to any constituency in China.

Campaign During the fall of 1920 a campaign was inaugurated to raise money for seven oriental colleges for women under a joint committee which represented the Boards coöperating in these union colleges. Ginling, Yenching, and the Women's Medical College of Peking (now affiliated with Shantung Christian University) were the China units in the campaign for \$3,000,000. A pledge of one dollar for every two raised from other sources was made by the Laura Spellman Rockefeller Fund. This was used to equalize the gifts to the separate colleges.

The appeal was made primarily to the women of America and during the years 1921 and 1922 women all over the country were working to raise the money for these college buildings. The leading spirit in the campaign was Mrs. Henry W. Peabody and her untiring zeal through the two years inspired thousands of other women to attempt the impossible. "It could not be done, but they did it," and in February 1923 a cable was received "Fund

complete." There was great rejoicing all round the world. The colleges are richer not only in money but in a host of new friends.

Ginling Ginling had plans ready in the summer of 1919, drawn by Murphy and Dana of New York and Shanghai. Gifts in pledges to Ginling in advance of the campaign were sufficient to warrant making a start in the summer of 1921. Within two years six buildings were completed and a seventh will be ready in the spring of 1924. This group will house 200 students when residence for faculty is provided. The total cost including work on the campus will approximate \$450,000 gold.

Yenching At Yenching the buildings for the women have gone forward on the new campus planned for Peking Christian University.

Woman's Medical College The removal of the Woman's Medical College to Tsinan is being made possible by the funds received in this joint campaign. Faculty and students are now housed in the new women's hostel. Work will be done in connection with the Shantung Medical School and the coöperation will make for economy in equipment and for better work. Shantung is also admitting women to courses in Religious Education. Dr. Luella Miner is acting as Dean of Women.

College Architecture Both Ginling and Yenching have carried out the idea of adopting Chinese architecture to modern uses. The Ginling buildings are of solid fire-proof construction. Within sunshine floods the rooms, and every essential requirement of modern school buildings has been considered, adopted to Chinese needs and ways of doing things. The exteriors are in Chinese style. Color has been used with some restraint. The columns of the three buildings of the main quadrangle are red, those of the residences are a dark olive green. The wall surfaces are sand-colored stucco and the roofs dark gray tile. The buildings stand as a symbol of the spirit of lavish giving of which the story of the alabaster box preserves the Master's praise.

CHAPTER LIII

THE POPULAR EDUCATION MOVEMENT

J. C. Yen

Purpose "To Make China's Illiterate Millions Reading and Intelligent Citizens" is the primary purpose of the Popular Education Movement.

The Classical Language and the Literary Revolution One of the principal factors that accounts for the high percentage of illiteracy in China (where learning and scholarship is universally revered by high and low alike) is the extreme difficulty of the Chinese Classical language. For centuries it had been the only recognized literary medium. To learn to use it with any degree of proficiency means a lifetime of study. This at once puts it beyond the reach of the common man.

One result of the Literary Revolution (1917-1919) is the substitution of the Pai Hua (spoken language) for the classical language for literary purposes. Since 1919 the Pai Hua has spread throughout the length and breadth of the land. Not only are standard works on philosophy and sociology published in Pai Hua, but by virtue of its very simple and natural style the number of novels, periodicals, weeklies and dailies has been multiplied many times. It has practically won its place as the "Kuo Yü" or National Language of China to-day.

The Problem That the adoption of Pai Hua simplifies immensely the process of learning the written language needs no proof, but the bigger problem of teaching the three hundred and twenty illiterate millions to read the language still remains. It is estimated that to make education universal throughout China, ten million schools with fifteen million more teachers are needed. At the present rate of development of educational facilities how many generations will it take before even a fraction of the illiterate millions have a chance?

In the solution of this problem successful and far-reaching results have been achieved by the following methods and in the following centers:—

I. *The "Foundation" System.*

The most immediate as well as the most fundamental step in educating the illiterate masses was to work out a system by which they might acquire a maximum practical vocabulary within the shortest possible time and at the least possible cost. After years of research conducted by the Popular Education Section of the National Committee of the Y. M. C. A. and the College of Education, National Southeastern University, Nanking, the system finally developed was the "Foundation Character" Course, a course consisting of one thousand of the most commonly used 字 in Pai Hua. Based upon this selected vocabulary four Readers called: "Popular Thousand Character Lessons" (平民千字課) containing twenty-four lessons each were prepared. The time required for the completion of this course is four months of classroom work of one and a half hours each week-day. Mastery of this course gives the common man a foundation knowledge of Pai Hua and enables him to write simple letters, keep accounts, and read simple newspapers intelligently.

II. *Educational Campaign.*

Having developed an Educational System the next immediate step was to discover some practical device by which it would be put into effective operation. It was clearly understood that in promoting mass education of this kind no spasmodic or individual attempts would be of much avail. *Organized and coöperative efforts* in the form of a city-wide educational campaign have been found practical and effective. An adequate educational campaign aims at enlisting as many volunteer workers as possible and coördinating all the forces available in any given community. Responsibilities of finance and staff for the campaign are placed entirely on the *local* leaders: for this is a campaign not only to educate the illiterate that they may become intelligent citizens, but also one to educate the rich and the literate to share their

possessions with their less-privileged fellow-countrymen. They may do this by making contributions to the campaign fund and by volunteering to serve as teachers, supervisors, or in other capacities required by the campaign.

To test the value and the practicability of the educational system and the campaign plan, Changsha* in Hunan, was chosen for the first experiment.

The Changsha Campaign The first Changsha campaign (March to July 1922) proved to be more than a successful experiment. The results aroused so much enthusiasm that the city decided to continue the schools from term to term until the goal of "All Changsha Literate" was reached. In September of the same year Changsha enrolled over fifteen hundred new illiterates. After four months of study of one and one-half hours each week-day, another final examination was held and one thousand and ten passed successfully. The town once more celebrated a big commencement in a typical Chinese manner!

The Chefoo Campaign The success of the Changsha campaign gave the promoters encouragement to try experiments in other parts of China. The next center chosen was Chefoo in the province of Shantung. As in Changsha, the Chefoo Y.M.C.A. promoted the campaign. The plan adopted in Chefoo was practically the same as that used in the Changsha campaign. A general Committee of leading citizens was organized and the same five sub-committees were elected.

The whole town was back of the campaign. Shops and schools were closed on the day of the opening mass meeting. The attendance proved to be so big that it was necessary to hold simultaneous meetings in two places, the largest guildhall and the largest theater in town. The meetings were immediately followed by a city-wide educational parade in which 15,000 business men, students (both men and women) gentry, scholars and artisans participated.

* For an account of the origin of the Movement and the Changsha campaign. See Chapter XXV of the China Mission Year Book, 1923.

Educational Parade Over 300 high school boys and girls and students of normal schools volunteered to serve as recruiters. Fifty-two teams were organized and sent out to canvas the 52 districts as mapped out by the Recruiting Committee. In two days' time the boys' teams enrolled 1466 boys and men, and the girls teams 633 girls and women. Their ages are classified as follows:

(A) *Boys and Men:*

From eight to twelve	242
From twelve to fifteen.....	392
From fifteen to twenty.....	478
From twenty to thirty.....	264
From thirty to fifty-four.....	90
	<hr/>
Total.....	1466

(B) *Girls and Women:*

From eight to twelve	115
From twelve to fifteen.....	230
From fifteen to twenty.....	199
From twenty to thirty.....	56
From thirty to fifty-two.....	33
	<hr/>
Total.....	633

The 100 volunteer teachers (70 men and 30 women) were recruited chiefly from the faculties of the schools, though a good number of them were business people, gentry, evangelists and Bible women. These teachers likewise received no salary, but \$4.00 a month was allowed each for ricksha fare. Five men and two women supervisors were elected by the teachers.

Besides teaching these pupils the "Popular Thousand Character Lesson," there were a number of supplementary activities. The classes were taught the meaning of the National flag and to sing the National Anthem. Frequently half an hour was taken for a lecture on health, morals, citizenship and religion. Monthly socials for the students and teachers were conducted, sometimes meeting by districts and at other times all coming together.

Commencement

Of the 2099 students enrolled over 1600 attended the classes till the last day. Final examinations were held July 29th-30th 1923. On August 1st. the city celebrated the biggest Commencement in all the history of the Province. Mme. Hsiung Hsi Ling, wife of the ex-premier, was the principal speaker. All the high officials, civil and military, and representatives of practically every organization in the city attended the occasion. The Chinese Police and the American Fleet bands furnished the music. Certificates were presented by Mme. Hsiung to 1147 candidates of whom 372 were girls and women, and 775 were boys and men. The presence of so many women graduates was both unique and inspiring. First prizes in the form of scholarships were given to the three students receiving the highest marks during the term. Second prizes were granted to the twenty standing next highest, and the three best of each class were rewarded with the opportunity of continuing their study in the "Peoples Continuation Schools" which were established on their behalf. The slogan of the campaign was: "To make Chefoo 100% literate within five years".

The Kashing Experiment

While the Changsha and Chefoo campaigns were in progress an experiment of great significance was being conducted in the Kashing High School, Kashing, Chekiang Province. A scheme of visual instruction using the stereopticon was worked out.

The entire lesson for the evening was thrown on the screen. There first appeared, to the delight of every eye, a colored picture illustrating the character lesson. All the ingenuity of the teacher was brought to bear in making this picture a part of the pupil's life. Then appeared the character lesson which was explained and taught by the teacher, sentence by sentence. Finally came the individual new characters which were enormously magnified. After repeated drills, slide by slide and character by character lights were thrown on for further review. Each student began to review the entire lesson (which had appeared on the screen) in his text book. Meanwhile slates were

brought out and each one learned to write the characters he had seen magnified on the screen.

At the end of the term we are forced to the conclusion that not only can large numbers (200 to 500) be handled by one teacher but that the work can be carried forward on this quantity basis with greater speed and with higher grade results than in the individual small class.

On July 21, 1923, there was held in the Kashing City Hall the most remarkable graduation ever seen in this little southern town. More than seven hundred people attended. The Mayors of Kasban and Kashing were present to give out the diplomas and prizes.

Inspired by the results of the experiment, the leaders of Kashing have since organized a special committee for popular education with the richest man in town as chairman.

Under the leadership of the Y.M.C.A., Hangchow launched a city-wide campaign last September 1923. The campaign plan adopted was practically the same as that in Changsha and Chefoo. However, in one particular it was unique, namely, instead of the College and Middle School students recruiting the illiterates, the police force volunteered for service. Over 800 strong turned out and canvassed the city!

Over 2000 illiterates were enrolled. One hundred and two volunteer teachers taught in eighty-four schools (61 for men and 23 for women) scattered throughout the city. They ranged in age from twelve to sixty: from 12 to 15, 46%, from 16 to 25, 37% and from 26 to 60, 17%. According to occupations, excepting the 339 whose data were not available, there were 606 artisans, 208 labourers, 135 pedlars, 29 apprentices, 14 soldiers, and 274 without employment.

After four months of schooling, 1668 students (1223 male and 445 female) came and took the final examination, and January 20, 1924 was set as the auspicious day for the big graduation. Representatives of the Civil Governor, the Commissioner of Education and other leading educators and business men of the city were present to witness this unusual spectacle of literary aspirants. One thousand four

The
Hangchow
Campaign

hundred and twenty-nine students, men and women, received diplomas from the magistrate at this big Commencement.

THE FOLLOW-UP PROGRAM

I. Continuation Schools:

After graduating the students are given an opportunity to go through another four months' schooling in the Continuation Schools where such subjects as civics, geography, arithmetic, history, elementary science, ethics and sanitation are taught.

II. Scholarship:

Among the graduates of the schools there will doubtless be found a good number who will be worthy of further training in middle schools or even in colleges and universities. The well-to-do among them should be encouraged to go to higher institutions of learning while the poor but deserving ones should be provided with scholarships.

III. Literature:

Follow-Up Literature on various lines written in simple and attractive style is of the utmost importance. Books and pamphlets on citizenship, science, sanitation, industry, economics, ethics, history, geography and other literature like stories, biographies and songs are either published or under preparation. The "Commoners' Weekly" based upon the 1000 Foundation Characters, edited and published by the Kashing High School has reached its twelfth issue.

IV. Reading Clubs:

Reading Clubs are intended chiefly for these graduates who are desirous of furthering their education but who, for one reason or another, cannot attend school.

THE FORMATION OF THE NATIONAL POPULAR EDUCATIONAL ASSOCIATION (中華平民教育促進會)

It was natural that the results of these (above mentioned) experiments in Popular Education should attract the attention of many of the leading educators and

social workers of the country. Among them are Mme. Hsiung Hsi-ling, Drs. W. T. Tao, Yuan Hsi-tao, Hu Shih and Huang Yen-pei. At the call of Mme. Hsiung, these gentlemen, together with several others, met for two consecutive days in Shanghai May (1923), to discuss ways and means of extending the movement for Popular Education throughout the country. As a result of the meeting, a preorganization committee was formed with a view to establishing a national association to promote the work.

With the coöperation of the National Association for the Advancement of Education, a National Convention on Popular Education was called by this committee in Tsing-hua College, Peking, August 20-25, 1923. Twenty provinces were represented. The spirit of unity and the earnestness of the delegates was something unknown in previous National Conferences. The result of the five-day meeting was the organization of the National Popular Education Association (中華平民教育促進會) which was formally inaugurated on August 26th, 1923 with headquarters in Peking. The Association has a National Board of Directors which is composed of two representatives elected from each province. Madame Hsiung Hsi-ling was elected the chairman of the Board and concurrently of the National Popular Educational Association.

**The Activities
of the National
Association**

Unlike most of the organizations formed nowadays in China, this National Association set to work immediately. The first working center scheduled was Peking, but this had to be given up on account of the disturbed conditions there. However, under the leadership of Madame Hsiung a very extensive campaign was launched last summer in Nanking. Governor Chi Hsieh Yuan, hon. chairman of the Association, gave \$10,000 to the work. There are now altogether 120 schools with a total enrollment of 5,000 students both men and women, boys and girls.

The first group of the five thousand students enrolled had their first graduation on December 22nd last, in the Public Recreation Ground. Civil Governor Han Tsz Shih, one of the strongest supporters of the Popular Education Movement, spoke at the commencement and gave out 602

diplomas. Madame Hsiung was also present to distribute the prizes. Over six thousand people attended this occasion.

The Wu-han Campaign At the invitation of the leading citizens, Madame Hsiung, Dr. W. T. Tao and the writer helped to launch another campaign of far-reaching significance in Wu-Han last November.

Governor Hsiao Yao Nan gave \$1,000 of his personal funds to the Movement and the assembly granted \$20,000 as an annual contribution in order that the work may be carried out on a large scale.

Extensive plans are being made in Shanghai, Canton, Foochow, Ningpo, Tientsin, Soochow and Kaifeng this spring. Both the National Popular Education Association and the National Committee Y. M. C. A. have been invited to help in launching their respective campaigns.

CHAPTER LIV

THE MOVEMENT FOR AN ALPHABET AND FOR THE SIMPLIFICATION OF THE CHARACTERS

Yü T'ang Lin

As long as we feel the need of making the spread of knowledge more general and the acquirement of it more easy for the people of China, so long will the problem of the reform of the written language remain an important one for all those interested in the uplift of China. But the difficulty of the problem has been greatly exaggerated.

**Three
Movements** At present there are three parallel movements which all work toward the end of making the written language simpler than it is now with the time-honored characters. They are (1), the movement for the simplification of the characters themselves, (2) the movement for the already officially promulgated syllabary, i.e. the *Chu-yin Tzŭ-mu*, and (3) the movement for romanization. Of these three, the first and last are comparatively the more recently started movements.

**Alphabetic
Writing** As the prime essentials for the success of an alphabetic writing are of course (1) that the spoken language itself should be standardized and unified, so that there is something definite to alphabetize, and (2) that the spoken language should also be accepted as the literary language of the country, for there is no sense in alphabetizing a language which no one dares to use in writing books and which is only conceived to be vulgar. In this connection, it may be noted that even advocates of alphabetic writing admit that alphabetization of the old literary style cannot be intelligible to the reader, whereas, they believe beyond the shadow of a doubt that alphabetization of the *peh-hua* or vernacular style can be understood, if it is done properly.

Happily, the two above-named requisites of success for an alphabetic writing in China are well provided for, so that we may confidently say now that the way for the introduction of an alphabet (or of the Roman letters in particular) is wide open. For the spoken language has already been accepted as the literary language, and it is being increasingly unified and standardized.

Old Characters Here is not the place for arguments, yet the general bearing this problem has on the discarding or retention of the old characters must be made clear. The general position of most advocates of romanization with regard to the disposal of the characters may be summarized thus: An alphabetic writing of the general written language of China is absolutely necessary, no matter what else (including the characters), you may have besides.

Simplification of Character For some time yet the old characters will remain in general use, and to a limited extent, they will always remain in use in this country. Hence the need of simplifying them and making them, as far as is practicable, easy to write. This in the main becomes the work of reducing the number of strokes for a character.

The way in which a character may be simplified may be (a) to adopt its form in cursive script, (b) to write only one part of the whole character, (c) to modify part of it, (d) to substitute for it its ancient form, (e) to use a simpler phonetic particle, (f) to invent a new form, (g) or to make use of the form for another word. The distinguishing trait about these proposed reforms is that, everywhere, it has been the object to follow the line of natural development only, and to give official sanction to forms which have evolved themselves on doctors' prescriptions, pawn-shop bills, etc., which are already in current use, but which hitherto have been considered as "incorrect". Some examples are: Of the class (a) 为 for 爲, 实 for 實; (b) 声 for 聲, 虽 for 雖; (c) 边 for 邊, 刘 for 劉, (d) 从 for 從, 礼 for 禮; (e) 迂 for 遷, 远 for 遠; (f) 𠂇 for 衆, 灶 for 竈; (g) 几 for 幾, 旧 for 舊.

Another proposal to write only the so-called "phonetic particle" of a character without the "radical" element (which indicates the class of its meaning)—the idea of Chancellor Ts'ai Yüan-p'ei, for example—seems to have much less prospect of public approval.

The *Chu-yin*
Tzu-mu The alphabet of 40 letters (not Roman) which is now in current use or at least being taught in the schools and elsewhere was officially promulgated by order of the Ministry of Education on December 23, 1918. It was, however, made already in 1923 by the Commission on the Unification of Pronunciation called together under the auspices of the Ministry of Education. Previous to this, there had been quite a number of attempts at making an alphabet, but only by private individuals, (notably Wong Chao and Lao Nai-hsüan). In December, 1920, an order of the Ministry of Education was issued giving official sanction to a Dictionary of Standard Pronunciation (*Kuo-yin Tze-tien*), standardizing the sounds of 8000 characters which had been prepared by the above-named Commission. At about the same time, a most important ministerial order was given for the adoption of textbooks in the "National Language" (really the spoken mandarin) instead of in the old literary language in the primary schools. An attached condition to this order was that the *Chu-yin tse-mu* might be used. As a matter of fact, this system of alphabet is being taught in most schools to-day, in the middle schools, all normal schools, and the higher normal schools and colleges, especially those in Peking. A Commission on the Unification of the National Language, (*Kuo-yü t'ung-i Hui*) was formed in 1919. This Commission had its fifth annual session in the fall of 1922 and now has about a hundred members, having for its Chairman Minister Chang Yi-lin, and for its Vice-Chairmen Yüan Hsi-t'ao and Wu Ching-hêng. About a dozen dictionaries are now on the market using the alphabet to indicate the pronunciation of words.

This Alphabet was originally intended to be written by the side of the characters and to run from the top downwards. It may be however used alone, and has been successfully written running from left to right like English.

The 24 Consonants

		<i>Wade</i>	<i>Remarks</i>
ㄅ	—	p	— p in "spy"
ㄆ	—	p'	— p in "pie"
ㄇ	—	m	
ㄈ	—	f	
ㄏ	—	v	
ㄉ	—	t	— t in "sty"
ㄊ	—	t'	— t in "tie"
ㄋ	—	n	— before a, o, u only
ㄌ	—	l	
ㄍ	—	k	— k in "sky"
ㄎ	—	k'	— k in "kite"
ㄎ	—	ng	— ng in "(si)nger"
ㄐ	—	h	
ㄑ	—	ch	} before i, ü only
ㄑ	—	ch'	
ㄑ	—	n	
ㄑ	—	hs	} before a, o, u only; made with the tip of the tongue very curled back.
ㄑ	—	ch	
ㄑ	—	ch'	
ㄑ	—	sh	} approximately like g in "rouge" with tongue curled.
ㄑ	—	j	
ㄑ	—	ts, tz	— ts in "sits"
ㄑ	—	ts', tz'	— aspirated ts.
ㄑ	—	s, ss	

The 3 Medials

		<i>Wade</i>	<i>Remarks</i>
—	—	i	} Used before the "finals", thus: u + ai = uai, i + an = ian
×	—	u	
ㄩ	—	ü	

The 13 Finals

ㄚ	—	a	— a in "car"
ㄛ	—	o	— for words from Rimes 歌, 戈
ㄜ	—	ê	— ir in "girl." Newly added for words from Rimes 職, 德
ㄝ	—	eh	— example: Wade's "chieh." Only after i, and ü.

ㄅ	—	ai	—	i in "bite"
ㄆ	—	ei	—	ay in "pay"
ㄇ	—	au	—	ou in "loud"
ㄏ	—	ou	—	o in "go," but with an open o
ㄏ	—	an	—	
ㄏ	—	ang	—	
ㄏ	—	ên	—	} used after i, u, ü to form Wade's "in", "ing", "un" etc.
ㄏ	—	êng	—	
ㄏ	—	erh	—	with an opener ê—sound than "ir" in "girl"

§§§ Unrepresented are Wade's "ih" in *shih*, and "ü" in *ssu*, *tzu*, where the consonant would stand alone representing the whole syllable, (thus "tz" to be read as "tzü" and "sh" to be read as "shih").

Different types of the Chu-yin Tzū-mu, the "round," the "square," the "German," the "script" type, etc. have been invented. Below are two specimens in horizontal writing of the "square" and the "script" style respectively:

A. The "square" type:

Yüü hi cxtiü þ « ㄞ ㄅㄆㄇㄏ ㄇㄉ ㄏㄏㄏㄏ ㄏㄏ ㄏㄏ. ㄅㄆㄇㄏ ㄏ
 ㄏㄏ、ㄏㄏ、ㄏㄏ ㄏㄏ ㄏㄏ ㄏㄏ ㄏㄏㄏㄏㄏ ㄏㄏ ㄏㄏ、ㄏㄏㄏ ㄏㄏㄏㄏㄏ ㄏㄏ ㄏㄏㄏㄏ、ㄏㄏㄏㄏ、
 ㄏㄏㄏ ㄏㄏ ㄏㄏㄏ ㄏㄏ ㄏㄏㄏㄏ、ㄏㄏㄏㄏ ㄏㄏ ㄏㄏㄏㄏ. ㄅㄆㄇㄏ « ㄅ ㄆㄆㄆ、

B. The "script" type (for the same text):

Yüü hi cxtiü þ « ㄞ ㄅㄆㄇㄏ ㄇㄉ ㄏㄏㄏㄏ ㄏㄏ ㄏㄏ. ㄅㄆㄇㄏ ㄏ
 ㄏㄏ、ㄏㄏ、ㄏㄏ ㄏㄏ ㄏㄏ ㄏㄏㄏㄏㄏ ㄏㄏ ㄏㄏ、ㄏㄏㄏ ㄏㄏㄏㄏㄏ ㄏㄏ ㄏㄏㄏㄏ、ㄏㄏㄏㄏ、
 ㄏㄏㄏ ㄏㄏㄏㄏㄏ ㄏㄏ ㄏㄏㄏㄏ、ㄏㄏㄏㄏ ㄏㄏ ㄏㄏㄏㄏ、ㄏㄏㄏㄏ ㄏㄏ ㄏㄏㄏ ㄏㄏ
 ㄏㄏㄏㄏ、ㄏㄏㄏㄏ ㄏㄏ ㄏㄏㄏㄏ. ㄅㄆㄇㄏ « ㄅ ㄆㄆㄆ、

The Move-
ment for
Romanization

Although the Chu-yin Tzū-mu has already enjoyed a palpable success, it has never been acknowledged as a satisfactory solution of the language reform problem. On the contrary, it seems rather to represent the half-hearted spirit of the stage when people do not yet dare to conceive of an

alphabetic writing existing for its own sake, and serving the entire purpose of written communications. As the name implies, the *Chu-yin* alphabet is only to indicate (*chu*) the pronunciation (*yin*) of the characters. In this spirit and primarily for this purpose has this system of alphabet been devised and adopted. It was nothing more than an interlinear system of pronunciation marks. As time went, the original purpose of the alphabet has been shifted, and the possibility of its use independent of the characters came to represent the turn of specialist opinion. As soon, however, as the idea of an independent alphabetic writing comes to the front, the deficiencies of the said system of alphabet become all too apparent. There is no proper provision for indicating the tones; it is not elastic enough to represent dialectic differences; its letters are often clumsy; they are not made for connected writing, so that letters often have to be written disjointedly, entailing a loss of time; they have not been chosen out of practical considerations for ease and convenience, but because they are remnants of some primeval signs; they mean a meaningless and purposeless deviation from the system of writing to-day accepted in most civilized countries, the Roman letters; they are incapable of transcribing foreign names, etc. In fact when one thinks of the problem in its main aspect, and if one does not let himself be swayed by the very transient and insignificant fact that the *Chu-yin Tzū-mu* has already made some progress, one cannot but come to the conclusion that a satisfactory system of romanization would be the best of all possible alphabets in the long run. Misconceptions that these Roman letters in fifty years from now will not look as "Chinese" as they now look "English", have of course to be cleared away from the people's and even the officials' minds.

Romanization

At the fifth annual session of the Commission on the Unification of the National Language, a resolution was proposed by Prof. Ch'ien Hsüan-t'ung of the Peking National University that a committee should be appointed to consider the question of Romanization of the National Language (*Kuo-yü Lo-ma-tze*), and after a rather hard fight, was passed by the whole Commission. The committee now consists of

about a dozen people. The results of study by these people will from time to time be published in the National Language Magazine, the monthly organ of the "National Language Promotion Association" a private institution established seven or eight years ago. No. 7 of vol. I (special number, called "Reformation of Chinese Characters") and No. 1 of vol. II of the said monthly (published by Chung Hwa Book Co.) contain important practical suggestions on the method of Romanization. A definite advance has been made along the line of indicating tones by whole letters instead of by diacritical marks or by Arabic figures as is done by Wade. Thus it is for instance possible to write

than ttan thaan thann
 instead of t'an¹ t'an² t'an³ t'an⁴

or *uei, wei weei wey* for the four tones of *uei* respectively. Hyphens will be done away with for polysyllabic words, whose syllables will be written together to form one individual word, as a recognizable unit. These units should then be standardized.

Any doubt about the possibility of romanizing Chinese spoken language will be answered by the following short formula:—Any language which is intelligible when heard in speaking can also be made intelligible when seen in writing. If the writing is not intelligible, the fault must be in the imperfectness of method (such as the omission of tone differences and faulty word divisions).

CHAPTER LV

PRESENT USE OF PHONETIC SYSTEMS IN TEACHING ILLITERATES TO READ THE BIBLE

A. G. Bryson

ANHUI	Mission	Church Constituency	Read N. T. Frequently	In Character	In Nat. Phonetic	In Wong Chao	In Romanized	Measures taken to help Christians and enquirers to learn to read the Bible
Anking ...	A.C.M.	2500	M.20% W.50%	All	1%	—	—	
Anking	C.I.M.	150	75%	99%	1%	—	—	National script for women.
Chéng Yang Kuan.	C.I.M.	118	50%	98%	2%	—	—	School for girls.
Tai Ho.....	C.I.M.	90	50%	90%	10%	—	—	Reading classes: natural phonetic.
Ying Chow.....	C.I.M.	250	50%	mostly. a few	—	—	—	
Chu Chow	U.C.M.S.	197	76%	All	—	—	—	Night school at Church.
Wuhu	M.E.F.B.	523	50%	99½%	½%	—	—	A few night classes, national script results disappointing.

3828 55%

Constituency

National Survey.....11608 45% Communicant illiterates



CHEKIANG	Mission	Church Constituency	Read N. T. Fluently	In Character	In Nat. Phonetic	In Wong Chao	In Romanized	
Chu Chow	C.I.M.	279	35%	All	—	—	—	
Lanchi.....	"	200	70%	"	7%	—	8%	Women's classes in <i>character</i> .
Nan Sing Chiao ...	"	16	100%	"	—	—	—	
Sien-ku	"	144	60%	50%	None	None	50%	Classes in <i>character</i> and <i>romanized</i> .
Hangchow	C.M.S.	3000	?	?	"	"	—	For whole Chekiang Field.
Ningpo	"	4000	35%	75%	"	"	25%	Schools, station classes.
Hangchow College Church	P.N.	300	98%	All	"	"	—	Classes.
Ningpo	"	2000	62%	75%	"	"	25%	Classes for men, women and girls' night schools, and village classes.
Huchow	M.E.S.	3400	10%	All	"	"	None	
National Survey.....		48079	49%	Communicant illiterates				
		13339	53%					

CHIH LI		Mission	Church Constituency	Read N. T. fluently	In Character	In Nat. Phonetic	In Wong (Chao)	In Romanized	1-12.
Changli	M.E.M.	3000	25%	80%	20%	—	—	1. Classes in character.
Chêngan	C.N.	250	30%	95%	—	—	—	2. Classes in national script.
Ta Ming	C.N.	53	100%	85%	15%	—	—	3. Phonetic classes.
Hokien	S.P.G.	350	30%	All	None	a few	None	4. Occasional night schools.
Pao-an	N.C.M.	39	60%	All	—	—	—	5. Teach national phonetic.
Paoting	P.N.	1200	50%	85%	15%	—	—	6. Catechumen classes in which National Script is taught.
Shih Chia Chuang	A.G.	73	25%	75%	21%	4%	—	7. Steady course required.
Siao Chang	L.M.S.	1400	59%	50%	—	50%	—	8. Great success with Wong Chao system.
Tsangchow	L.M.S.	1200	70%	60%	40%	—	—	9. Little teaching in phonetic, more in character.
Tientsin	L.M.S.	469	—	—	—	—	—	10. Special classes.
Tientsin	A.B.C.F.M.	2000	33%	All	—	—	—	11. Evening meetings, and individual instruction.
Tungchow	"	3300	33%	99%	1%	—	—	12. Classes for women in character
Shuntelhu	P.N. City	222	70%	All?	Some	Some	—	
		District	175						
National Survey			37089	49%	Communicant illiterates			

FUKIEN		Mission	Church Constituency	Read N. T. fluently	In Character	In Nat. Phonetic	In Wong Chao	In Romanized	
FutsingC.M.S.	14069	20%	95%	—	—	—	5%	1. Teach romanized, local phonetic and colloquial character. 2. A woman's school.
Kao San Shih	830	25%	Nearly all	—	—	—	—	3. Romanized classes; 600 characters and Y.M.C.A. readers have been tried.
Kienning	240	M.70% W.85%	all the men	a few	—	most of the women	—	4. Teach Bible in colloquial character. 5. Night reading classes, women's classes. 6. In women's, boys and girls' schools, etc. 7. National Phonetic and romanized unusable in many dialects. 8. Classes and individual teaching. 9. Station classes, women's school.
Ing taiA.B.C.F.M.	2000	20%	All	None	None	perhaps 20'	—	
Shao Wu	3000	10%	"	"	"	"	None	
ShanghangE.P.M.	800	60%	90%	"	"	"	10%	
TingchowL.M.S.	2500	20%	All	"	"	"	None	
YukiM.E.F.B.	500	50%	90%	10%	—	—	—	
F'u-anC.M.S.	238	50%	All	—	—	—	—	
National Survey	86094	40%	Communicant illiterates					
		24177	37%						

HONAN	Mission	Church Constituency	Adults	Read N. T. Fluently	In Character	In Nat. Phonetic	In Wong Chao	In Romanized	
Kaifeng	C.E.C.	1258	69%	100%	10%	—	—	—	1. Three women's schools and five men's station classes. Reading classes both in character and phonetic.
Kaifeng	F.M.A.	300	60%	90%	10%	—	—	—	2.
Kingtzekuan.....	C.I.M.	?	?	?	leader only	—	—	—	3. "Wong Chao still best system."
Kwangchow	"	4000	50%	80%	20%	—	—	—	4. Bible classes, short term schools, and individual help.
Shangtsai	"	340	47%	All	None	None	None	None	5. Classes for enquirers.
Taikang	"	600	30%	"	"	a few	"	"	6. Bible classes.
Kweiteh	L.B.M.	100	35%	"	"	None	"	"	
Suiping	L.U.M.	219	65%	"	"	—	—	—	
Tengchow	N.L.K.	287	70%	86%	14%	—	—	—	
Yüchow	A.U.G.	280	66%	83%	17%	—	—	—	
Wu-an	P.C.C.	600	50%	90%	10%	—	—	—	
Weihwei	P.C.C.	700	60%	95%	5%	—	—	—	7. National phonetic used by some foreigners.
Shiwu	"	250	50%	40%	10%	—	a few	—	8. Evangelists teach national script.

National Survey.....20636 54% Communicant illiterates

8934 54%

HUNAN		Mission	Church	Adults	Read N. T. fluently	In Character	In Nat. Phonetic	In Woyong Chiao	In Romanized	
Ansiang	C.H.M.	73	92%	All	—	—	—	—	1. Course for enquirers.
Changsha	B.T.P.	10	All	"	None	None	None	None	2. Night schools.
Changsha	S.D.A.	420	90%	"	—	—	—	—	
Changsha	W.M.M.S.	1922	30%	?	—	—	—	—	
Changteh	P.N.	—	—	—	—	—	—	—	3. Educational work.
Hengchow	P.N.	1160	50%	All	a few	None	None	None	4.
Hengshan	C.I.M.	100	66%	"	None	"	"	"	
Liyang	W.M.M.S.	623	50%	"	"	"	"	"	5. Night schools; women's schools;
Ningsiang	N.M.S.	402	75%	"	"	"	"	"	6. Character taught.
Shenchow	E.A.	50	80%	"	"	"	"	"	7.
Siangsiang	C.I.M.	212	50%	"	"	"	"	"	8. Special dialect, phonetic script difficult.
Siangtan	U.E.	200	nearly all	All	None	None	None	None	
Sinning	C.I.M.	67	65%	"	"	"	"	"	9. Teach national phonetic.
Tsingchow	C.I.M.	157	20%	"	"	"	"	"	10. Reading classes.
Tungting	N.M.S.	1100	M. 80% W. 20%	"	"	"	"	"	
Tzeli	F.M.S.	450	50%	48%	2%	"	"	"	11. Bible classes.
Yüanchow	C.I.M.	500	5%	All	50%	"	"	"	12. Teach character and phonetic.
Yungui	R.C.U.S.	30	66%	"	"	"	"	"	13. Night school, women study character.
Yungting	F.M.S.	394	50%	50%	a few	"	"	"	14. Evangelists teach.
			7870	59%						
National Survey			22383	34%	Communicant illiterates				

MISSION	CHURCH CONSTITUENCY	ADULTS	READ N. T. FLUENTLY	IN CHARACTER	IN NAT. PHONETIC	IN WONG CHAO	IN ROMANIZED	
ANLU	W. M. M. S.	550	50%	90% a few	None	None	None	1. School, classes for women.
HANKOW	S. D. A.	1301	65%	98%	"	"	2%	2. Classes and daily study.
MACHENG	S. M. F.	200	70%	All	"	"	None	3. Evening classes.
SIAOKAN	L. M. S.	?	?	?	?	"	"	4. Women learn character and Wong Chao.
TA YEH	W. M. M. S.	380	25%	All	None	"	"	
TEI-AN	"	250	35%	"	"	"	"	5. Night schools.
TSAO SHIH	L. M. S.	2000	50%	"	"	"	"	6.
WUOHANG	C. A.	180	40%	"	"	"	"	7. Character class for women.
WUOHANG	L. M. S.	300	M. 40% W. 5%	All	None	None	None	8. Enquirers' study class.
WUOHANG	W. M. M. S.	176	80%	"	"	"	"	9.
<hr/>								
NATIONAL SURVEY		26364	56%	Communicant illiterates				
		5337	49%					

KANSU		Mission	Church Constituency	Adults	Read N. T. Fluently	In Character	In Nat. Phonetic	In Wong Chao	In Romanized	
Ku Yuan	S.A.M.	160	40%	All	None	None	None	None	Teach phonetic and character.
Ning Sia	C.I.M.	50	50%	"	"	"	"	"	Read Bible every Monday.
Si Fêng Chên	S.A.M.	35	90%	"	"	"	"	"	Schools and classes.
Ti Tao	C.A.	80	30%	"	"	"	"	"	Classes for women and men.
			325	52%						
National Survey			2519	60%	Communicant illiterates					
KIANGSI										
Changning	A.B.F.M.S.	450	70%	All	1%	None	None	5%	
Fuehow	G.C.A.M.	519	20%	"	None	"	None	None	Teach catechism in character.
Nanchang	A.C.M.	114	46%	"	1%	"	"	"	Women taught some character.
Nanchang	M.E.F.B.								
Ning Tu	G.C.A.M.	191	40%	"	None	"	"	"	
Sin Fêng	C.I.M.	160	8%	"	"	"	"	"	
Tsung Jên	G.C.A.M.	123	20%	"	"	"	"	"	Teach catechism in character.
Tung Siang	C.I.M.	64	20%	"	"	"	"	"	
Wuning	N.K.M.	500	10%	"	2%	"	"	"	
			2121	30%						
National Survey			15319	42%	Communicant illiterates					

Mission	Church Constituency Adults	Read N. T. Frequently	In Character	In Nat. Phonetic	In Wong Chiao	In Romanized	
Changshu M.E.S.	200	70%	All '3 or 4'	None	None	None	
Chinkiang C.L.M.	15	80%	"	None	"	"	Classes teach character and pho- netic.
Chinkiang M.E.F.B.	280	60%	"	"	"	"	
Chinkiang P.S.	?	40%	"	"	"	"	
Kiangpu A.G.	7		"	"	"	"	
Kiangyin P.S.	867	54%	"	"	"	"	
Nanking C.M.Bots	30	100%	"	"	"	"	Women's schools, night schools, individuals taught at home.
Nanking U.C.M.S.	1280	71%	"	"	"	"	
Shanghai C.C.A.	62	80%	"	"	"	"	
Shanghai L.M.S.	990	80%	"	"	"	"	Shanghai and Soochow phonetic being introduced.
Shanghai S.B.B.	150	75%	All None	None	None	None	Schools.
Soochow P.N.	400	50%	98%	2%	"	"	
Wusih S.B.C.	329	65%	All None	"	"	"	Teach character.
Yangchow A.C.M.	169	90%	"	"	"	"	Teach character.
<hr/>							
National Survey.....	7084	36%	Communicant illiterates				
	4761	70%					

KWANGSI	Mission	Church Constituency Adults	Read N. T. fluently	In Character	In Nat. Phonetic	In Wong Chiao	In Romanized	Weekly class for Christians, etc.	
								All	None
Kweilin	S.B.C.	250	30%	All	None	None	None	None	Weekly class for Christians, etc.
Nanning	S.D.A.	150	65%	"	"	"	"	"	Special Bible study class.
Wuchow	C.A.	250	75%	"	"	"	"	"	
Wuchow	W.M.M.S.	200	20%	"	"	"	"	"	
National Survey		5861	53%	Communicant illiterates					

850 48%

Mission	Church Constituency Adults	Read N. T. Fidelity	In Character	In Nat. Phonetic	In Wong (Kwa)	In Romanized	
Canton	78	57%	All	None	None	None	1. Daily Bible reading.
Canton	16000	33%	97%	"	"	3%	2. Night classes.
Canton	700	45%	All	"	"	"	3. Night classes.
Chonglok.....	1057	40%	?	"	"	"	4. Schools.
Hokshihia	705	40%	All	"	Some old people	"	5. Bible classes
Kaohkek.....	1180	10%	"	"	"	"	6.
Kaying.....	800	60%	"	"	"	"	7.
Kichung	222	40%	"	"	"	"	8. Some instruction to male and women enquirers.
Kongmoon	1500	M. 40% W. 15%	"	"	"	"	9.
Kongtsun.....	411	60%	"	"	"	"	10. No new people learn Cantonese romanized now. Phonetic no use.
Pakhoi	159	40%	75%	None	None	25%	11. Teach character and ro- manized.
Pakhoi	300	60%	"	None	None	"	12. Teach phonetics.
Shuichow	759	40%	All	"	Mostly women	"	
Takhing	600	20%	"	"	a little	"	
Tungkun	210	40%	"	"	None	"	
Linchow	840	25%	"	"	"	"	

National Survey..... 25221 40% Communicant illiterates
78519 475%

SHANSI	Mission	Church Constituency	Read N. T. fluently	In Character	In Nat. Phonetic	In Wong (Chao)	In Romanized	
Fenchow	A. B. C. F. M.	12000	53%	98%	2%	None	None	1. Use popular education campaign books.
Hokü	N. M. C.	4						
Kiangchow	C. I. M.	120	60%	All	1%	"	"	2. Bible classes.
Kü-wo	"	100	70%	90%	10%	"	"	3. Classes for phonetic.
Luchêng	"	100	20%	All	None	"	"	4. Bible classes.
Pingting	C. B. M.	220	82%	Nearly All	a few	"	"	5. Short term and evening classes.
Pingyao	C. I. M.	140	33%	practi- cally all	"	"	"	6. Station classes, home work.
Siaoyi	"	150	90%	All	None	"	"	7. Few learn phonetic as a step to character.
Taiyüanfu	B. M. S.	285	90%	All	a few	None	10%	8. Women's school, and classes.
Yicheng	C. I. M.	125	75%	91%	"	"	9%	9. Teach women in occasional monthly classes.
Yuncheng	(S. M. C.) C. I. M.	656	79%	All	10%			10. Special classes, Sunday school classes for phonetic script.
6 Churches in G. W. Shansi								
National Survey		13298	40%	Communicant illiterates				
		13800	65%					

SHANTUNG	Mission	Church Constituency	Adults	Read N. T. Fluently	In Character	In Nat. Phonetic	In Wong Chiao	In Kowantze	
IchowP.N.	1200	50%	95%	5%	None	None	None	Bible and night classes.
KiaochohBn.	280	50%	All	None	"	"	"	
KiaochohS.B.M.	697	50%	"	"	"	"	"	Schools and evening classes.
NinghaiC.I.M.	22	75%	"	"	"	"	"	Bible reading.
ShanhsienCh. M.M.S.	240		Almost All	a few	"	"	"	
ShihiaoC.M.M.L.	30	80%	All	None	"	"	"	Teaching to read N. T.
Tai-anM.E.F.B.	765	35%	"	"	"	"	"	Every member using phonetic.
TsiningP.N.	1937	15%	95%	5%	"	"	"	Country classes teach phonetic.
WeihaiweiS.P.G.	12		"	None	"	"	"	
Yih sienP.N.	314	50%	All	"	"	"	"	Bible classes, institutes, night schools.
National Survey.....		53480	56%	Communicant illiterates					
		5497	50%						

SHENSI	Mission	Church Constituency	Adults	Read N. T. Fluently	In Character	In Nat. Phonetic	In Wong Chao	In Romanized	
Hanchéng	S.M.C.	400	70%	Nearly All women	None	None	None	School for women.	
Lonan	Nn. A.M.	144	28%	All	3%	"	"		
Pehunchén	S.A.M.	26	33%	"	None	"	"	Six enquirers read national script.	
Sanyuan	B.M.S.	5000	65%	94%	6%	"	"	Literacy a condition of Church membership.	
Puehng	(S.M.C.) C.I.M.	inc. 260	60%	almost All	one or two	"	"	Teach character and national phonetic script.	
National Survey		5830 12257	51% 54%	Communicant illiterates					
SZECHWAN									
Fowehow	M.C.C.	200	75%	All	None	None	None	1. Work with women, men, boys and girls.	
Kiating	A.B.F.M.S.	400	69%	"	"	"	"	2. Night school in Church.	
Kwangyüan	C.I.M.	117	50%	"	"	"	"	3.	
Mienchow	C.M.S.	250	10%	"	a few	"	"	4.	
Süchow	A.B.F.M.S.	410	70%	"	"	"	"	5. Teach (60) characters and phonetic script.	
Tze-lin-tsing	M.C.C.	2141	35%	"	"	"	"	6. Night schools and Bible study classes.	
Ningyuen	A.B.F.M.S.	60	60%	"	"	"	"	7.	
National Survey		3578 32942	52% 33%	Communicant illiterates					

MANCHURIA	Mission	Church Constituency	Read N. T. fluently	In Character	In Nat. Phonetic	In Wong Chiao	In Romanized		
Kirin.....	P.C.I.	508	75%	All	None	None	None	1. Learn to read catechism and a <i>Gospel</i> .	
Sinchiêng Petuna....	D.M.S.	67	80%	95%	5%	"	"	2. Bible women teach enquirers character.	
Chi'oyang	U.F.S.	600	60%	All	None	"	"	3.	
Fa-ku-mèn	P.C.I.	600	80%	"	"	"	"	4. Mission schools have learnt and teach phonetic.	
Hingking.....	U.F.S.	468	50%	90%	10%	"	"	5. Promote national phonetic in classes.	
Liaoyang	U.F.S.	1465	80%	All	None	"	"	6. Yearly classes in phonetic.	
Moukden	U.F.S.	2650	80%	"	"	"	"	7. Classes for illiterates.	
Siuyen	D.M.S.	144	70%	"	10%	"	"		
Ta-ku-shan	D.M.S.	300	80%	"	"	"	"		
		6602	73%						
National Survey.....		30575	56%	Communicant illiterates					

CHAPTER LVI

THE STUDENT VOLUNTEER MOVEMENT

Jung Fang Li

The Student Volunteer Movement, as a national factor, was formally organized at Tung Chow in May, 1910. The purpose of this movement has been for the encouragement of young people (women excluded) to take up ministry as their life work. So far the movement has been a success. In the year 1922 the membership had already-reached 1570, of which 130 are actually in the ministry, besides many who are helping the church in indirect ways.

National Convention In August, 1922, a National Convention was held at Kuling; there were present from sixteen provinces, one hundred and sixty representatives. The constitution was formally adopted; this provides for a National Council with a membership of thirty, one third of which shall be students. There is also an executive committee of seven of whom one must be a student, elected from the Council

The Constitution also provides for a National Convention every three years, for inspirational as well as legislative purposes. The basis of membership was reconsidered in the Convention. After long deliberation and discussion, the Conference adopted the narrower basis for membership, namely, that only those who choose the ministry as their life work, should be admitted to the movement.

Purpose Soon after the Convention, the secretaries made a circular visit over ten provinces, where they found that many of the students were not clear with regard to the purpose of this movement. These may be divided into three groups: (a) those who have chosen the ministry as their life work; (b) those who have made up their minds to serve as church workers but not

necessarily ministers; (c) those, who have agreed to serve as local preachers but refuse to receive pay from the church.

The secretaries were a little bothered with this situation. They sent out a circular letter to each one of the members inquiring about his present position. In response to these circulars two hundred and seventy-eight students from twenty-five schools replied. Among these, there were one hundred and twenty-two belonging to (a) class, ninety-seven to (b) class, and fifty-nine to (c) class.

The secretaries set the findings before the executive committee, which met on January 26, 1923. After some careful deliberation the executive committee again indorsed the narrower basis for membership.

Basis for Membership This however did not settle the question of the basis for membership. The Chihli group, in their retreat at Wo Fo Szu, with a delegation of one hundred and three, passed the following recommendations:

1. That the Volunteer Movement should broaden its basis so as to include all the vocations which have as their sole object the promotion of the Chinese Christian Church.

2. That women students should be admitted into the movement.

In relation to this, they sent out a circular letter stating their point of view. They feel that the Chinese pastors have long been under restraint, financially, intellectually, and spiritually, and that they have lost most of their power of initiative. Moreover the Church is so much Americanized or Europeanized, that she is inadequate to meet the needs of the Chinese community. Her barriers are many; her cleavages great. In order to make the church indigenous, some radical changes must be made in her organization. They feel, therefore, that other forms of service, such as educational, medical, literary and social, are equally needed in the Chinese Christian Church. Furthermore they feel that some ministers should serve the church as lay preachers without burdening her with financial obligations. They regard the present basis of membership as too narrow to meet these needs. Its scope should be enlarged so as to

include both men and women, whose sole purpose is to prepare for the building up of the Chinese Christian Church.

Women The position has been strengthened by the
Members White Cross at Canton Christian College and the Union Middle School, where they admit both men and women, whose sole purpose is for the advancement of the Kingdom of God, with no regard to their profession. Meanwhile the Shantung group, in their retreat this year, admitted two girls' schools into the movement. These are some of the questions under consideration which cannot be settled before the next National Conference in 1925.

The movement at present has: 89 branches, 15 of which are of College Grade: 763 members (based on the old as well as the new report), with

Rev. Z. T. Kaung,	Mr. P. H. Tai,
Rev. J. H. Blackstone,	Rev. F. J. White,
Rev. K. T. Chung,	Dr. David Z. T. Yui, and
Rev. C. E. Patton,	as its Executive Committee.

The secretaries are:—

Rev. Ting Li Mei,
 Rev. Egbert M. Hayes,
 Rev. M. Gardner Tewksbury.

CHAPTER LVII

CHINESE STUDENTS ABROAD

Y. Y. TSI

The aim of this article is to present a composite picture of the present condition of Chinese students in Japan, North America, Great Britain, Germany and France and to raise the question, as to what place this group of more than 9,000 students should have in our Christian programme as viewed from the home base in China?

Number of Students No official statistics of Chinese students abroad exist. The consulates and legations do not know. The educational commissioners residing abroad do not know, although it is their business to know. The student associations have about the best estimates. Just before the earthquake, Japan had about 2,200 Chinese students, but a number of them have since returned to China. The United States has over 2,000 in colleges and universities and probably another 1,000 in public and high schools. This does not include those in the Hawaiian Islands. The larger groups are, Columbia (150), M. I. T. (57), Harvard (50), Chicago (80), Pennsylvania (60), Wisconsin (50), Michigan (60), N. Y. U. (60), California (60), Illinois (70). Canada has only about 20 Chinese university students. In Great Britain there are 180, mostly in the universities and technical colleges, like London (75), Glasgow (9), Leeds (14), Cambridge (24), Edinburgh (40), Manchester (10), Oxford (5). Of the 2,000 in France, 1,500 are what are known as *etudiants-ouvriers*, who work in the factories in the day time and attend school in the evenings. The "Chinese University" at Lyons has a hundred or so. Not many are students of college or university grade. Germany has approximately 1,000 distributed as follows: Berlin (700), Gottingen (40), Frankfurt (10), Dresden (10), etc. Belgium has

about 75, mostly in the Industrial University at Charleroi, the Universite du Travail. Small groups are also found in Italy, Switzerland and other European countries.

Major Subjects of Study Chinese students in America take up studies of all kinds, ranging from philosophy to photography and from economics to aeronautics. But the triad of major studies are economics, education, and engineering. A lesser triad is medicine, physical sciences, and political science. A rather thorough search of the American theological seminaries in 1922 revealed the fact that 20 Chinese students were registered in them, of whom just 11 were planning to enter the ministry. In other words the Chinese churches of the next generation will not be manned by men trained abroad.

In Great Britain the favorite studies are economics, medicine and law, the first claiming the largest number of devotees. In France the pure sciences, engineering and literature seem to be most popular, while in Germany engineering, medicine and physical sciences dominate. In Japan the major studies are political science and education.

Social Conditions Concerning Chinese students in Japan, an American Y. M. C. A. Secretary who has worked among them for a number of years wrote: "Because of the poverty of the average Chinese student he is forced to secure board and room at the cheapest possible place. This condition throws him into contact with the lowest class of small Japanese inn-keepers. His early impressions of Japan are most unfavorable and unfortunate. The majority of the students who have been receiving a government grant are short of funds because their allowances since June (1921) have been irregular. The reason for the destitution is the present unfavorable exchange. Another reason is the present costs of all commodities in Japan."

In France The etudiants-ouvriers Chinois went to France in large numbers in 1920 with practically no funds in their pockets but with great hopes in their hearts, through the influence of the Socièté Franco-Chinois d'Education. Many of them met with

extreme hardships after arriving at Marseilles. Mr. W. J. Wen, who was there and saw the conditions wrote, "The majority were sorely disappointed and had to be content to work as manual laborers with meagre wages which barely sufficed for their living and allowed no savings for schooling." At present these students have still to work in the factories, but their condition has been much bettered. They earn about 25 francs for a 9 hour working day. The French people are tolerant in their attitude toward foreigners. They show no racial prejudice on the one hand and on the other express no particular interest in their presence.

In Germany Chinese students in Germany seem to live in comparative comfort, as contrasted with the plight of German students. But in their present mood, the German people dislike the presence of foreigners in their midst for reasons which can be readily understood.

In British Isles In the British Isles the Chinese students find a hospitable and congenial atmosphere. The majority of them come from wealthy families in British colonies in southern Asia. They know the English language and manners well and so fall readily into the British way of life.

In America In America, 400 Chinese are supported by Tsinghua scholarships, 250 by provincial scholarships, the rest are so-called private students. Like some American students, a few of the Chinese students work their way through college, but on account of racial differences it is not always easy to do that. Racial prejudice is fairly strong in America and Chinese students now and then meet with discourteous treatment, but on the whole as far as college communities are concerned, the people show a cordial attitude.

Student Organizations in America Chinese students in America are well organized. The Chinese Students' Alliance (C. S. A.) links together the local Chinese Student Clubs (C. S. C.) in a national federation and through the *Chinese Students' Monthly* and the *Chinese Students' Quarterly*, published respectively in English and in Chinese, and the summer conferences, creates a united *esprit de corps* among the students. These

conferences play an important part in Chinese student life. Aside from their intellectual and patriotic function, they serve the valuable purpose of bringing the young people together socially and as a result, many a matrimonial venture has its beginning at these gatherings. The Chinese Students' Christian Association (C. S. C. A.) founded in 1909 by men like C. T. Wang, W. C. Chen, David Yui, P. W. Kuo, is another active organization in America. Its purpose is to unite Christian and other students into a closer fellowship for mutual helpfulness in Christian living and services.

Student Organizations in Great Britain In Great Britain the two organizations are the Chinese Students' Central Union and the Chinese Students' Christian Union. These two bodies hold a joint conference every summer. The tendency to unite for closer fellowship and mutual help is not strong among the Chinese students on the Continent. The University of Paris has no Chinese Students' Club.

The Chinese students in France have no national organization. The Y. M. C. A. des Etudiants Chinois en France was in existence from 1919 to 1923 and was disbanded when the Y. M. C. A. National Committee of China withdrew its support. Berlin with 700 Chinese students has a Chinesischer Studentenverein with its own club-house, but there is no national organization for Chinese students in Germany.

Attitude Toward Christianity The attitude toward Christianity depends upon previous religious training in China and the social environment abroad. Referring to Chinese students in France, Mr. W. J. Wen wrote, "The Society (Société Franco-Chinoise d'Education) declared orally and in writing their anti-religion policy, have which makes it impossible for their students to have anything to do with any religious organizations, including the Y. M. C. A. in France". Mr. T. J. Cheng, Y. M. C. A. Secretary in France, 1919-1923 wrote, "If we neglect it (Y. work) we shall probably have to face a group of well-prepared anti-Christian leaders in the future." The Catholic type of religious life on the one hand and the prevalence of radical thought on the other seem to have

exercised an unfavorable influence on Chinese students in France in their attitude toward religion.

In the summer of 1923, Mr. Joseph Huang, with the help of a few other Christian students and of Mr. Leithauser, organized the first Christian conference for Chinese students in Germany. But on the whole there is pronounced indifference among the Chinese students in Germany toward religion, as one Christian student who has resided in Berlin for ten years said that he seldom thought of going to church and almost never went.

In Great Britain, the religious atmosphere is comparatively more helpful. At different student centers, Bible classes are found, and students attend Swanwick and other summer conferences.

Effect of Residence Abroad on Faith One fourth of the Chinese college students in America are baptized Christians. Very few of them have any church homes. In fact the general impression one gets among the Chinese students is that they are less enthusiastic about their faith and less active about Church affairs in America than in China. A few are like the students who declared, "I was once (a Christian) but am one no longer," "I nearly accepted Christianity as I understood it in China, but have changed my mind. I have lost my faith in Christianity since coming to America."

Causes A number of causes have conspired to produce this unhappy result. The congenial friendships and family and community ties which bind us to the church at home are absent. The American college youth is in an iconoclastic mood and the Chinese student, thrown into his company, concludes that it represents the general educated American attitude toward religion. The rationalistic atmosphere in American colleges has an harmful effect upon those who have been brought up in homes and churches of ultra-conservative theology. The disillusionment caused by contact with undesirable and un-Christian phases of social life in America, such as racial prejudice against men of a different color, chills the foreign student's religious spirit. The lack of

opportunity for self-expression in church life, including corporate worship, leads to indifference.

The Faithful Ones In spite of unfavorable conditions, a fairly good number of the students succeed in re-adjusting themselves to the new environment and maintain their Christian convictions and relationships. Usually they are the fortunate ones who have found good Christian friends, who have been related to Christian homes, who have been early in their stay in America affiliated with a congenial church, or received inspiration at a summer conference. As one student has put it, "We are not won by the philosophy of Christianity but by its evidences." Another amplified the idea by saying, "Christianity is not taught but caught. The best thing you can do is to help Chinese students to come into contact with the best and truest Christians, so that they can get Christianity subconsciously as it were. Then the prejudice toward nominal Christianity, will also disappear." From a student who joined the Christian Church at a Northfield summer conference come these stirring words, "I am trying to stand for Christ now and always, and expect to Christianize China, America and also the whole world. First of all, America ought to be Christianized thoroughly—I mean to make every nominal Christian a true Christian in his words and deeds. It would be uneconomical in time and energy, to wait for China to export Christianity to the "Christian" United States. Concerning the helpful influence of the Christian summer conference for college students, another wrote enthusiastically as follows, "The conference lasted for one week only, but its influence on me will be life-long . . . I can say that the conference has brought me back to Christianity . . . I know there are a good many Chinese students who are dissatisfied with the way the Americans treat them. To those students I venture to give a bit of suggestion, namely, to go to some of these conferences so as to find out the difference between the real Christians and the nominal Christians. After all there are some thinking Americans who do have the welfare of humanity in the depth of their hearts and who are now fighting for the good of humanity as a whole. Why should we not join our hands with them?"

**Attitude to
Denomina-
tionalism**

Many an earnest student cannot tolerate denominationalism though quite sincerely religious, like the one who wrote, "I am not a member of any denomination and will not be. I believe in the principles of Christianity and am trying my best to live up to them. But I will not be disturbed by the petty differences of the churches and I will therefore ignore all the unnecessary formalities. My religious struggle has a long history and up to the present has had no outside influences. I began to realize how weak we are and how constantly we have to come back to our Lord lest we shall go astray in the next step."

Quite a number of the Chinese students abroad entertain unfriendly ideas about the missionary enterprise as it is carried on in China. Much of the prejudice is due to ignorance of the motives and policies of missions, much to their bitterness toward foreign aggressions, sometimes done in the name of the missionary enterprise, and much to nationalistic sensitiveness. Recently a caustic article on Missions in China appeared in the *Nation*. It came from the pen of a Christian student, a product of one of the very mission colleges which he attacked. In a personal talk with him, the writer found him not as anti-Christian as that article seemed to indicate. In fact, he was quite interested in the future of the Church in China, and took an evident delight in telling the writer that his youngest brother, the brightest in the family, was a student volunteer for the ministry in China. At first glance, one would naturally be taken aback to find a graduate of a mission college in China making a bitter attack against it. But may it not be explained as being due to some fault in the educational process, which has brought on the reaction? For instance, we may honestly ask, "Is the compulsory chapel attendance or the requirement of a certain number of hours of religious instruction in the mission college justified from the viewpoint of results and of sound educational principles? Might not the compulsory nature of the requirements create prejudice and leave a bad taste in the mouth?"

Not Anti-Missionary

It will be wrong to conclude that the Chinese student abroad is rabidly anti-missionary. Warm appreciation of missionary efforts and achievements especially in medicine and education in China is freely expressed among them. "I am more impressed by the missionary work carried on in China than anything else that foreign nations have done in China." "Missionaries in China have done wonderful work. They have contributed a great deal to the modernization of the country." "Christian missionaries have wonderfully enlightened and helped China. They are getting away from the general disfavor arising out of the fact that they in earlier times meant (unconsciously) the vanguard of foreign imperialism in China."

The Challenge and the Response

The strategic importance of winning Chinese students abroad to a reasonable appreciation of the principles of Christian living and thinking and to a friendly attitude toward the Christian movement in China cannot be exaggerated. Furthermore, how unstatesmanlike it will be, if after having spent large sums and much energy in training young men and young women in the Christian colleges and churches in China and in preparing them for higher education abroad, we should cease to take an interest in their spiritual welfare and allow them to drift away from the Christian churches while they are in foreign lands so that later they return to China indifferent and cold toward the Christian Cause. Sporadic efforts here and there will not accomplish anything. A concerted and sustained effort in which the Christian forces in China and the mission boards and churches abroad are united can accomplish a great deal.

Contacts

At the present time, the different mission boards do maintain more or less close contact with the students of their own denominations. More can be done in this respect. The churches and colleges in China from which the students go abroad with a few exceptions have not given adequate attention to their own students away from China. A systematic process of letters of dismissal and introduction, and of sustained relationship through correspondence should be attempted. The local

churches, associations and individual friends in many college communities in America have shown active interest in Chinese students. They are entitled to greater encouragement and appreciation than they have received from China. The Committee on Friendly Relations Among Foreign Students of the International Committee of the Y.M.C.A. of North America with its annual budget of over \$35,000, and the Committee of Friendly Relations among Foreign Woman Students of the National Board of the Y.W.C.A., in the United States, have been of great service to Chinese students in helping them to adjust themselves to their new environment, in opening Christian homes to them, in cultivating friendly relationships, in overcoming racial prejudice, and in paving the way for a more favorable understanding of the Christian message. Student Movements in Great Britain and Europe have done similar work.

A notable example of church work for Chinese Students Abroad is the Chinese Church at Tokyo. The wisdom of supporting such work is demonstrated in the number of earnest Christians it has won among the Chinese students in Tokyo and the fine laymen and church workers it has prepared for and sent back to the church in China.

The Y.M.C.A. in China has been of substantial help to students proceeding to foreign countries in attending to the business arrangements for them, in providing receptions and farewell meetings at their departure and in issuing introductory letters to Associations abroad. The Association also gives attention to returning students and helps them re-adjust themselves in the community to which they return.

Most Difficult Problem The most difficult problem in this type of student work is to maintain the personal relationship which alone is of lasting value. Mass or impersonal service is useful in its place and in providing opportunity for the personal contacts. After all, no "Student Bureau", or any other official organization, can take the place of personal relationships. Such relationships exist for instance between the teacher and his student, the pastor and his church-member and the

“Y.” secretary and his Association member. Would that every college teacher, every pastor and every “Y.” secretary in China would maintain friendly relationships with his own students, his own church members and his own Association members as they sojourn abroad, and take a keen interest in their spiritual welfare as parents in that if their sons and daughters away from home. Only in this way, which involves personal interest and labor, can we hope to meet the challenge of the Chinese students abroad in an adequate and fruitful way.

NOTE: The information about Chinese students in Great Britain, France and Germany was secured by the writer on his visit to those countries in the summer of 1923. The information about Chinese students in America comes from his personal observations through three years of travelling among the colleges of the United States and Canada.

CHAPTER LVIII

SCHOOLS FOR MISSIONARIES' CHILDREN

Charles L. Boynton

Missionaries have generally been regarded as prolific: they are by temperament, by conviction and by occupation, educationists. It is not surprising, therefore, that they have always been keenly interested in the problem of the education of their own children, as well as in that of those to whom they have been sent. China presents no exception, but she has long presented a problem, to which the solution is being found with an increasing degree of satisfaction in the last decade. For a century the problem of the education of foreign, or non-Oriental children, in China has been largely the problem of the education of missionary children; as a community problem it began to emerge in the late eighties and has become insistent since 1910.

This is apparent from even a casual survey of the compilation attempted in the *Christian Occupation of China*, which attempted a summary and detailed statement of all schools for foreign children in China. (Pp. 426-8) Before attempting an analysis of that survey and comment on more recent progress, a word is in point as to the solutions attempted and still in vogue.

Mother Teaching The earliest and still the commonest method of educating missionary children is mother-teaching. This is practiced wherever children are too few, or parents too limited in means to employ a professional teacher for a group. Formerly this type of instruction was continued till the first or second furlough in the homeland. The possibility of the necessity of continuing the method after furlough has kept many a family permanently in the homeland, and has been a great deterrent to second terms, and a greater deterrent to third terms in China. It has led to the establishment at the home base of "homes for missionaries' children" adjacent to

denominational preparatory schools and colleges. Some of our best missionaries in China to-day, of the second and third generations, are the educational product of these schools. So also are some of the bitterest opponents of foreign missions, children who felt the neglect of parents interested in the children of others, to the exclusion of natural care for their own. These homes and schools have served and will continue to serve a useful purpose, particularly for the children of these compelled to serve in lands where it is unsafe to bring up "foreign" children. But they have been seen to be only a partial solution.

Home-Group School The second step, in China, was the home-group school, where the children of a compound, rather than of a family, have been gathered under the tutelage of the better-trained or less occupied mothers, until such time as the resources of the group has permitted the supplementing of unprofessional with professional instruction. No figures have ever been gathered as to the prevalence of this method, but it must be somewhat widespread, as at least a score of one-teacher (professional) schools have come to the writer's attention during his investigations. This method has usually resulted in better discipline and more orderly study, with the advantages of social and competitive effort.

Of late a more highly differentiated and complex type of school has come to the fore and at the present time may be said to dominate in the education of the children of missionaries in China. It has been found by experiment, that with the increase of modern comforts, and the multiplication of sanitary precautions, China, at least from the Yangtze valley northward, affords several places where it is safe and healthful to keep foreign children even through the period of adolescence, in other words until the child is ready for a college or university training. This is due in part also to the very material increase of the foreign populations in China and their improved economic status, enabling them to establish and maintain schools worthy of the best educated group of people in a single occupation in the world.

**Schools
Established**

Of the forty-three schools listed in the survey mentioned, twenty were established and are maintained by Protestant missionary societies, six by Roman Catholics, nine by foreign municipal councils and eight are distinctly private schools. Of the twenty schools, fifteen gave statistics of enrollment, nine American schools enrolling 716 students, four British 309, two continental 50, making a total of nearly 900 known pupils. It is possible that their present total enrollment is nearer 1500 pupils (the Shanghai American School alone having increased from 253 to 390 in this period.) It will be seen that the problem is one of no small extent.

**American
Schools**

During the past five years the American schools particularly have felt the need for permanent equipment and expansion to meet growing needs. The Kuling School was the first to secure a dormitory and class-room building, which was completed in 1919. The Peking American School carried on a campaign in 1920-22 which resulted in gifts of Mex. \$100,000 and the completion in the fall of 1923 of a modern school building which serves also as a community center for Americans. The most ambitious project is that of the Shanghai American School, which began a campaign in 1918-19, a second in 1921, and is now engaged in a third.

The first building, a temporary structure in brick and stucco was completed in August, 1922, and accommodated seventy students in lower grades, while classwork for the others was carried on in rented quarters over five miles away. In September 1923 three permanent fireproof buildings in red brick and concrete were completed on the new fifteen-acre campus in the French Concession, Shanghai, and were occupied by over 300 students. These included a classroom building for 350 students, with dormitories in the attic for four teachers and forty boys, a three-unit dormitory for girls, accommodating 61 girls and seventeen members of the staff, a dining and music hall, with dining space for 200 and four studios and five music practice rooms, beside a teachers, reception room and the necessary service portion. During the fall the central heating plant and servants quarters were completed, and

a temporary Boy Scout House was erected. An artesian well has been bored, giving about 30,000 gallons of water per day, a pumphouse, 65 foot water tower, bicycle house, and principal's residence have followed in rapid succession, and the demands for space have necessitated the renting of additional quarters in the neighborhood to house two teachers and fourteen boys. The present campaign seeks to add another building for instruction, a three-unit boys' dormitory, a gymnasium and additional living quarters for teachers. The total sum expended on this project to date exceeds Mex. \$700,000, and the immediate campaign calls for Gold \$275,000 additional. This School has proved a new binding force between missionaries and the community, who share in its support and control on equal terms. The majority of the capital funds came from non-mission channels.

Future

It seems fair to assume that this program of expansion and development will continue, as the missionary and commercial communities are rapidly expanding. It is statistically demonstrable that most of these schools will require double their present facilities within a dozen years. The larger and stronger schools will continue to attract as many students in the upper classes as they can accommodate. The larger missionary centers will continue to demand and to develop professionally staffed schools for the younger children who can be kept at home. These schools of purely local scope will not require dormitories. The largest schools of this type at Peking and at Nanking include secondary as well as elementary education.

Coöperation

Among the American schools the competitive era seems to be wellnigh at an end and the period of coöperation has begun. A year ago an Association of these schools was organized including also similar schools in Japan, Korea, and India. The second meeting of this association is to be held at Peking in April. Coördination in curricula, coöperation in staffing and in financing, and interchange of experience have proved fruitful themes of discussion and correspondence.

It would not be surprising to see a genuine school system, somewhat closely knit together, emerge from these meetings and discussions, placing modern school facilities at the disposal of most foreign children in the Orient either by correspondence, or local, or residential schools. There is room for statesmanship here.

PART VIII
MEDICAL WORK
CHAPTER LIX

THE PUBLIC HEALTH MOVEMENT IN CHINA — 1922-23

John B. Grant

Little markedly encouraging may be noted during the year 1922-23 regarding official health work in China; in that respect, the present state of national public health reflects merely the general disturbed condition of national and provincial governments. For public health, just like education, is dependent upon government. Previous years have seen the dying out of many pretentious attempts as a result of governmental chaos.

Fortunately, in certain areas, industry, education and public health propoganda have quietly progressed through private initiative, especially in the most stable unit of the country — the Christian constituency.

**National
Activities** The Central Epidemic Prevention Bureau in Peking has increased markedly in efficiency, due chiefly to the reorganization effected by Dr. S. H. Ch'uan. If left undisturbed by politicians, it is on the road to making medicine in China independent of Western countries for sera and vaccines. This will mean a great saving in money and in life for the country.

The North Manchurian Plague Prevention Service with head-quarters at Harbin, under the direction of Dr. Wu Lien Teh, has continued functioning as efficiently as in previous years.

**Provincial
Activities** Public health was provided for in detail in the drawing up of theoretical government administration following the Revolution. In the intervening decade Kwangtung and

Shansi are the only areas in which serious attempts have been made to set up the machinery to carry out these provisions. Circumstances have prevented the fulfilling of the early promise of efficient health administration in Kwangtung. Unintelligent direction has prevented any degree of efficiency in the health machinery in Shansi.

The correlation of efforts by the Kiangsu Provincial Bureau of Entomology, the Southeastern University and the Kiangsu Police Department, has resulted in an encouraging initiation of fly and mosquito control in Nanking. This work may prove of more than local importance. The cyanide method devised by Professor Woodworth for economic agricultural purposes is described in his publications.

**Non-Official
Chinese
Activities** The movement to establish a National Health Association, sponsored by the Council on Health Education, in the fall of 1922, proved to have been premature. This was due to an absence of local organizations upon which a successful national movement must depend. Credit must be given to the sponsors for undertaking an experiment from which invaluable experience was obtained. Especial praise is due the fine spirit evidenced by the Executive Secretary, Dr. S. M. Woo.

Several local health movements took place, but lack of space prevents giving details.

**Mission
Activities** It is extremely encouraging to note the increasingly prominent place which is being accorded hygiene in all phases of mission work.

The general and rather sporadic health work of the past ten years has awakened public opinion to the necessity of wider and more specific effort. The period under review is important because it has shown this increasing crystallization of general ideas into specific activities, and permits the prediction of lines which the public health movement will take in the coming two decades.

Medical schools reflect the trend of events in the creation of departments of hygiene whose influence will be felt both through the graduate trained in preventive, as

well as curative, medicine, and through the experimental demonstrations of methods of hygiene application in China carried on as extra-mural activities.

Mission hospitals also are reflecting the spirit of the times by evidences of the growing feeling that work limited to curative medicine is not as constructive a demonstration of modern medical science as would be the inclusion of disease prevention. As increasing number of medical missionaries are utilizing their furloughs to study hygiene. Several of these have returned to full time preventive medical work.

Educators, especially after seeing the present scope of health conservation work in schools at home, are returning to China with the desire to secure better sanitation, health protection and health education for their students.

Appreciation by mission administrators of the need to secure greater practice of preventive medicine is seen in the beginnings of systematized effort in the health protection of Christian workers. Home Boards are not only more careful in medical examinations of candidates before they sail but are insisting that this care be followed up adequately on the field. This attitude is in turn reflected in the steps being taken by the National Christian Council for health conservation of its constituency.

Individual missionaries are undertaking health protection to a greater extent. The Kuling health survey by Dr. Atwater resulted in the community voluntarily undertaking the sanitation of that resort to a degree not possible ten years ago.

This growing appreciation of preventive medicine is being correlated and led by the Council on Health Education. Under the able direction of Dr. W. W. Peter, the Council has not waited for a public demand leading to the creation of a central organization, but has taken a leading part in creating the demand itself. Departments of (1) School Hygiene, (2) Child Health, (3) Community Hygiene, (4) Chinese Literature, have been created to handle more efficiently the diverse demands.

The varied needs of as large a constituency as the Christian bodies in China cannot be met efficiently without a central organization with a large and full time staff

like the Council on Health Education. This is because the financial and professional requirements for the preparation and carrying out of health programs can be supplied best through one central body. No single locality or organization, not entirely of a health nature, can afford to maintain the services necessary to publish literature, undertake publicity work or experimental demonstrations that are being carried on by the Council on Health Education. There is also the necessity for a clearing house where specially trained workers can aid local communities by bringing them the experience and judgment only obtainable through acquaintance with activities elsewhere.

The realization of the value and necessity of the Council on Health Education has been illustrated strikingly during the past year in several ways;

a. Five mission boards, despite debits at home and consequent curtailment of important field activities, have considered it worthwhile to renew their financial grants. One other mission board has for the first time given support to the Council.

b. The Women's Foreign Missionary Society of the Methodist Episcopal Church and the United Brethren Missionary Society, have joined the Y. M. C. A. and Y. W. C. A. in allocating full time foreign medical workers to the Council's staff.

c. The China Medical Board has entrusted to the Council the preparation and execution of a five year program to stimulate interest in medicine as a career, at the same time contributing to the Council's general activities.

Summary The Public Health Movement in China during 1922-23 in government circles has reflected the general political chaos. Exceptions to this are seen in such new ventures as the Central Epidemic Prevention Bureau in Peking and local health work in Nanking.

In mission circles progress has been satisfactory. Out-standing advance of an increased health consciousness has been seen in those activities focussing themselves on specific undertakings. This concentration due to the

worker in the field and the administrator at home was brought about by numerous interrelating factors, (1) of increased health activities in Great Britain and the United States, and to such specific reasons as, (2) the work of the Council on Health Education and, (3) to the efforts of individuals, such as Dr. Lennox, in showing the necessity of health conservation.

The immediate lines upon which efforts in hygiene have developed are:

1. The establishment in medical schools of separate departments to train medical practitioners in hygiene and in the undertaking of experimental demonstrations of community public health.

2. The provision for the beginnings of a specific program in mission education to train the future adult in the maintenance of health, the avoidance of disease and the development of a community health consciousness.

3. The beginnings of more systematic methods of health conservation of Christian workers.

4. The allotment by missions of full-time workers to health activities.

5. The undertaking of specific preventive medical work by scattered medical missions.

CHAPTER LX

WORK OF THE PEKING UNION MEDICAL COLLEGE

Henry S. Houghton

The Peking Union Medical College was established in 1906 by a group of missionary societies, three of which were British organizations and three American. In 1916 the China Medical Board, one of the subsidiary bodies of the Rockefeller Foundation, took over the land and buildings, and reorganized the College, assuming from that time the maintenance and new construction costs. A Premedical Department was organized, offering a three years' course in languages and in biology, physics and chemistry; English was adopted as the medium of instruction. The erection of a new group of hospital and medical school buildings was begun in 1917, and completed in 1921. The organization of the medical department is now practically complete, and classes are under instruction in every year of the prescribed course.

Organization The staff has been recruited partly from institutions in America, Great Britain and Europe, partly from among persons with experience in medical missionary work in China, and increasingly from well trained Chinese. The staff included in 1923 twenty-two premedical teachers, seventy-two teachers in the Medical School, thirty-two head and staff nurses, and thirty-one administrative and technical officers. There were in addition five visiting professors, thirty-two resident house officers, and sixty-four trained nurses. Of these one hundred twenty-four are foreigners, representing seven nationalities, and one hundred thirty-four are Chinese.

Program The primary objectives of the College include, in addition to premedical education, which is a temporary but important phase of the program:

1. Medical education
 - (a) Undergraduate courses
 - (b) Training of investigators, teachers, and clinical specialists through prolonged graduate courses and through practical work under guidance.
 - (c) Brief intensive graduate courses, open to practitioners and missionary doctors, both foreign and Chinese.
2. Medical research, especially with reference to problems of the Far East.
3. The fostering of professional ethics through the development of character and ideals of service.

Education Work

The College admits students of both sexes to the Medical School and Premedical School; women only are admitted to the School of Nursing. The enrolment for the academic year 1923-24 included sixty students in premedical courses and fifty-three in medical studies. Nineteen were registered in the School of Nursing. During the past year one hundred and fifty-three persons have been enrolled as graduate students, a few of whom have been admitted to regular undergraduate courses, and a larger number to special courses for graduates or to clinics for practical work in the various departments.

Admission to the several educational departments of the college is by examination only.

The course in medicine extends over four years, which must be supplemented by one year of special work in the laboratories or hospital before the degree is conferred. On the successful completion of these five years of medical studies, graduates receive the doctorate in medicine from the University of the State of New York, under which the College is chartered, and a special diploma from the Ministry of Education of the Chinese Government.

Graduate Work Exceptional opportunities are available to those desiring to do graduate work in medicine or to undertake individual research. The China Medical Board provides a limited number of fellowships to physicians in China who desire to take advantage of these

opportunities, the sum allowed being sufficient to meet the cost of maintenance and tuition fees. During the past two or three years the College has been fortunate in having as visiting professors a group of men eminent in special fields of medical science in other countries who have spent varying periods each year in Peking, coöperating in the work of teaching and research. During the current year the list includes Dr. W. P. Councilman, Shattuck Professor of Pathological Anatomy, Medical School of Harvard University, Dr. L. Emmett Holt, Clinical Professor of the Diseases of Children, College of Physicians and Surgeons of Columbia University, Dr. C. U. Ariëns Kappers, Director of the Central Institute of Brain Research, of Amsterdam, Holland, Dr. Adelbert Fuchs, of Vienna, and Dr. W. W. Cort, of the School of Hygiene and Public Health of Johns Hopkins University.

Religious and Social Work

The principal extra-curricular activities of the College are centered in a department of religious and social work, which exists to foster religious life and social interests. The work of the department follows two general principles; first, participation in all activities and exercises is purely voluntary; second, the program is planned to develop Christian faith and to train in service. The institution is entirely non-sectarian in its Christian character.

The responsibilities of the department cover many varied lines of work, and bring it into contact with all phases of the college program. Religious work among students includes an intimate advisory relation to the Student Christian Association, the conducting of Bible classes and of daily prayers in the dormitories, participation by student delegates in various summer inspirational and training conferences held in North China, and the maintenance of a college service of worship on Sundays. A Christian Association for nurses has also been established, and special Bible classes for this particular group and for technicians, conducted in the vernacular, are held regularly.

Evangelistic Work

Evangelistic work in the hospital and convalescent hostel is under the direct charge of the department, and a carefully selected

group of evangelists is assigned to bedside work and follow-up visitation among patients. This is closely correlated with the activities of the medical social service division, which is a part of the hospital administration. In the convalescent hostel, attention is directed also to other practical needs, such as manual work and instruction in phonetic script.

The distribution of religious and educational literature is another important phase of the hospital evangelistic work. Religious and secular tracts and periodicals, weeklies and dailies, are provided for ward patients and a small circulating library of 530 books is at the disposal of those who can read.

While the social and cultural activities of the student body are mainly in the hands of the students themselves, the department takes a large part in directing and assisting in a varied program. The Student Associations participate in the following:

**Student
Associations**

- (1) The Peking Christian Student Union
- (2) The Boys' Department of the Y. M. C. A. in making physical examinations
- (3) The Students' Rural Evangelistic Band
- (4) Night School for college employees
- (5) Summer Schools for poor children

In addition to the direction and guidance exercised in connection with the foregoing, the department maintains other educational and recreational features, such as weekly motion picture entertainments, a college lecture course, week-end outings for students, a student self-help bureau, and until recently, physical training for men and women—now cared for in other divisions. Social rooms for students are set apart in a building specially designed for this use, which contains also a spacious auditorium, committee rooms, a small assembly hall, and other features adapted to social and community purposes.

CHAPTER LXI

PHYSICAL CONDITION OF STUDENTS IN MISSION SCHOOLS

S. M. Woo

No Uniform Method Writing on a subject like this presupposes a knowledge gained from a series of carefully standardized physical examinations of the students of at least a few representative mission schools in every province of China. As far as I know such knowledge remains to be gained, simply because a vast majority of mission schools have not attempted any physical examination of their students; and among those mission schools that have conducted physical examinations of their students, very few did really complete and careful work. Moreover, there is no uniformity of method, so that the scanty data that are available are not strictly comparable with one another. For example, in a table prepared by a certain missionary doctor we have the following statistics.

<i>Schools</i>	<i>Disorders of Heart</i>	<i>Diseases of Lungs</i>
Shanghai College	20.4 %	20.4 %
Canton Christian College	13.0 %	.3 %
Yale in China	.8 %	4.1 %

It is extremely doubtful that heart disorders in Shanghai College were 25 times as prevalent as in Yale in China; and that the lung diseases were 68 times as prevalent there as in Canton Christian College. In view of the above considerations it must be admitted that the time is scarcely ripe for the writing of this paper. But on the other hand, the time is ripe for mission schools and hospitals to make a start to find out more about the physical conditions of the students in their respective missions.

Schools Studied This paper is based largely on the findings of the physical examinations of 3200 students in mission schools in Soochow and Hangechow, recently conducted (Oct. and Nov., 1923) by the Council

on Health Education in coöperation with the Christian Educational Associations of these cities. No conclusion must be drawn regarding the physical condition of students in mission schools elsewhere.

Physical Conditions Let us now examine the students' physical condition as revealed by (1) personal history; (2) physical examination; (3) microscopic findings; and (4) athletic records.

1. The physical condition of mission school students as revealed by personal histories. The analysis of 2030 histories of Soochow mission school students showed that 28% of the students had had malaria; 21.3% dysentery; 16.% ascaris; 13.5% typhoid fever; 6.5% diphtheria; 6.10% smallpox; 3.2% spitting of blood; 3.10% scarlet fever; 12.9% of the students had never been vaccinated; 8.4% of the students used the old fashioned smallpox inoculation; only 5.6% of them knew how to swim.

2. The physical conditions of students in mission schools as revealed by physical examination. This may again be discussed under the following headings; (a) height and weight, the most important indices of nutrition and growth; (b) lung expansion; (c) percentage of various defects.

a. Height and weight. The following tables were specially prepared to give some idea as to how the average heights and weights of Chinese students compare with the heights and weights of American students of the same age. The average heights and weights of the American boys and girls were taken from Wood's Height-weight table. The data for Chinese boys were taken from a table prepared by Prof. Nash of Soochow University, who took careful measurement of about 3,000 boys from Chekiang and Kiangsu. The data for the heights and weights of Chinese girls were taken from our Soochow series. In order to make allowance for the inaccuracy in Chinese ages, one year is taken out from all Chinese ages given. For example, Chinese children of six years-Chinese age-are compared with American children of five years, western age, etc.

Table showing the average heights and weights of American and Chinese boys of the same age —

Age	Average Height			Average Weight		
	Chinese	American	Difference	Chinese	American	Difference
11	51.7 in.	55.5 in.	3.8 in.	58.9 lbs.	77 lbs.	18.1 lbs.
12	55.9 "	58 "	2.1 "	64.9 "	83 "	18.1 "
13	57.5 "	61 "	3.5 "	76.1 "	99 "	22.9 "
14	59.8 "	63 "	3.2 "	84.9 "	117 "	32.1 "
15	59.5 "	64.5 "	5 "	90.9 "	130 "	39.1 "
16	64.5 "	65 "	.5 "	91.1 "	135 "	43.9 "
17	64.2 "	65.5 "	1.3 "	103.4 "	136 "	32.6 "
18	64.6 "	66 "	1.4 "	107.4 "	141 "	33.6 "

Average difference 2.6 inches. Average difference 30 lbs.

Table showing the average height and weight of Chinese and American girls of the same age. —

Age	Average Height			Average Weight		
	Chinese	American	Difference	Chinese	American	Difference
5	40.8 in.	42.5 in.	1.7 in.	35.8 lbs.	41 lbs.	5.2 lbs.
6	42.5 "	44 "	1.5 "	37.7 "	45 "	7.3 "
7	44 "	45.5 "	1.5 "	41.2 "	48 "	6.8 "
8	46.2 "	48 "	1.7 "	45.9 "	53 "	7.1 "
9	48.2 "	50.5 "	2.2 "	48.7 "	59.5 "	19.8 "
10	48.2 "	53 "	4.7 "	53 "	68 "	15 "
11	52.3 "	55.5 "	3.2 "	60.4 "	76 "	15.5 "
12	54.1 "	58 "	3.8 "	61.5 "	87 "	25.4 "
13	57.3 "	61 "	3.7 "	76.9 "	102 "	25.1 "
14	58 "	63 "	5 "	81.5 "	113 "	31.5 "
15	60.2 "	64.5 "	4.3 "	94.3 "	120.5 "	25.7 "
16	58.8 "	65 "	6.2 "	93.2 "	123 "	29.8 "
17	59.6 "	95.5 "	5.9 "	97.5 "	125.5 "	27.5 "
18	59.4 "	66 "	6.6 "	105 "	128 "	22.5 "

Average difference 3.7 inches. Average difference 18.2 lbs.

It will be seen from the above tables that Chinese boys in mission schools between 11 and 18 years of age are on the average 2.6 inches shorter and 30 pounds lighter than American boys of the same age. Similarly Chinese girls of mission schools, between 5 and 18 years of age, are on the average 3.7 inches shorter and 18.2 pounds lighter than American girls of the same age.

Lung Expansion (b) Analysis of a part of our Hangchow records shows the following result.

<i>Age</i>	<i>Average lung expansion</i>
7-9	1.5 inches
10-13	2.1 ,,
14-17	2.1 ,,

We were constantly struck by the fact that many students did not understand how to take a deep breath. The average expansion should be about 2 inches for the first group, 2.5 inches for the second group, and 3 inches for the third group.

Percentages c. The percentage of the various defects may be shown by the following tables—

Results of school medical examination, Hangchow, October, 1923. Total number of students examined, 1184. Total number of schools 22, including 1 kindergarten, 19 primary schools, 2 middle schools.

<i>Name of defect</i>	<i>Primary Schools</i>		<i>Middle Schools</i>	
	<i>Number</i>	<i>Percentage</i>	<i>Number</i>	<i>Percentage</i>
Teeth	430	47.8	56	19.7
Vision	322	36.1	123	43.6
Skin	313	34.3		
Trachoma... ..	285	31.6	85	30.2
Posture	282	31.3	23	8.1
Glands	248	27.5	4	1.4
Nutrition... ..	241	26.8	6	2
Color	239	26.5	6	2
Nose	236	26.2	9	3
Tonsils	217	24.1	53	18.7
Spine	114	12.6	13	4.5
Feet	85	9.4	46	16.1
Ears	68	7.5		
Lungs	59	6.5	38	13.3
Heart	15	1.6	24	8.5

Total number of students examined in primary schools 900, in middle schools 284.

Results Results of school medical examination, Soochow, December, 1923.

Total number of students examined 1986. Total number of schools 30, including 2 Kindergartens, 17 primary schools, 11 middle schools.

<i>Name of Defect</i>	<i>Number</i>	<i>Percentages</i>
1. Dirty Teeth	1655	83.3
2. Round shoulders	945	47.7
3. Pale Complexion... ..	696	35
4. Decayed teeth	587	29.5
5. Dirty skin... ..	582	29.3
6. Vision	478	28.2
7. Enlarged glands	516	25.9
8. Enlarged tonsils	475	23.9
9. Flat Chest... ..	421	21.2
10. Poor nutrition	363	18.2
11. Nose discharge	313	15.9
12. Flat feet	277	13.9
13. Deformed toes	197	9.9
14. Trachoma marked	196	5.8
15. Trachoma suspicious	194	9.7
16. Pyorrhoea	193	9.7
17. Scoliosis	123	6.1
18. Stooped posture	77	3.8
19. Anemia	64	3.2
20. Bow leg	57	2.8
21. Rales in lungs	57	2.8
22. Hunch back (Kyphosis)	55	2.7
23. Hernia	41	2
24. Tachycardia	39	1.9
25. Scabies	38	1.9
26. Pigeon breast	35	1.7
27. Discharging ear	31	1.5
28. Tinea of scalp	29	1.4
29. Heart murmur	28	1.4
30. T. B., suspected	26	1.3
31. Bronchitis... ..	24	1.2
32. Lordosis	21	1.05
33. Barrel chest	14	.7
34. Obstruction of nose	13	.6
35. Bound feet... ..	13	.6
36. Lameness	9	.4
37. Infected tonsil	6	.3
38. Saddle nose	5	.25
39. Goitre	5	.25
40. Wry neck	4	.2

41. Irregular heart beat	4	.2
42. All other defects	80	4.0

Defects A comparative study of the defects of students in middle and primary schools, both of the same missions, show the following interesting results—,

Defects of Nutrition...	Percentage of Defects	
	In middle schools	In primary schools
Defects of Nutrition...	9.9	40.7
„ „ Color ...	11.6	39.8
„ „ Posture ...	45.6	68
„ „ Spine ...	11.1	15.9
„ „ Nose ...	4.6	27
„ „ Ears ...	2.1	4.1
„ „ Teeth ...	139.1	141.2
„ „ Tonsils ...	16.9	21.2
„ „ Skin ...	19.4	33.7
„ „ Glands ...	10.5	46.2
Trachoma..	5.7	18.3

The ratio of defects is reversed in regard to extremities heart, lungs, vision, and hernia, as may be seen in the following table—,

Defects of middle schools' students		Defects of primary school students
Extremities	... 28.7	19.9
Vision	... 35.6	20.9
Hearts	... 5.5	.8
Lungs	... 5.6	2.6
Hernia	... 3.6	2.0

3 The Physical condition of students as revealed by microscopic findings:

Careful microscopic examination of 654 specimens of stools of college and middle school students by the Rockefeller Hookworm Commission shows infection by intestinal parasites in the following percentages; college-seniors 36%; juniors 48%; sophomores 49%; freshmen 52%; middle school students 65%.

4. The physical condition of students in mission schools as revealed by their athletic records. It scarcely requires any data to show that the students of mission schools have made tremendous progress in their athletic

ability within the last twenty years. About 18 years ago I saw a college man receive the most enthusiastic applause for putting the twelve pound shot a distance of 27 feet. To-day the record of the same college is 40 feet for shotput, and any man who cannot do 35 feet would hesitate to enter the contest. Eighteen years ago I saw a man who ran 880 yards in 3 minutes 10 seconds hailed as a hero. To-day such a slow coach would not dare enter the half mile race.

Summary We realize that our knowledge of the physical condition of students in mission schools is extremely limited. The personal histories of students reveal that they have suffered unduly from preventable diseases, particularly malaria, dysentery, typhoid fever, and smallpox.

Physical examinations shows that Chinese boys in mission schools are 2.6 inches shorter and 30 pounds lighter than American children of the same age! Chinese girls 3.7 inches and 18.2 pounds inferior to American girls of the same age.

The lung expansion of mission school students is decidedly deficient, averaging about 30% below normal expansion.

The percentages of various physical defects are high. In our soochow series each student averaged 4.5 defects. Defective teeth, poor vision, dirty skin, faulty posture, trachoma are among the most common defects.

Microscopic examination of stools shows high incidence of worms infection.

A comparative study of middle and primary schools in regard to frequency of physical defects and intestinal infections seems to show that mission schools, particularly boarding schools, are exerting a salutary effect on the health of students. Very much more, however, may be accomplished, if the mission school authorities will only introduce a modern educational hygiene program.

CHAPTER LXII

INTERDENOMINATIONAL AND NATIONAL SERVICE OF THE CHINA MEDICAL MISSIONARY ASSOCIATION

James L. Maxwell

INTERDENOMINATIONAL SERVICE

Conferences The Association holds biennial conferences of all the members that can be gathered at one time and place. At these such questions as medical evangelism, the place of the physician in the spiritual work of the hospital, the following up of patients after leaving the hospital and kindred subjects are discussed and much mutual help in the missionary side of hospital work is thus obtained. Nor is the scientific side of the work in any way neglected. The Association has always stood for the principle that anything less than the best in the professional work of the hospitals is dishonoring to the Master in Whose name we undertake this work. It seeks in these Conferences to give to the doctor working alone and amid many disadvantages the opportunity of learning and discussing the best and newest methods of treatment. It gives him an insight into the parasitic diseases, so common in China, as to their modes of infection and methods of treatment. Above all it makes the solitary doctor feel that he is one unit of a whole and not a mere individual fighting against seemingly overwhelming odds.

Doctors The great bulk of medical education, worth calling such, is in the hands of medical missionaries. This work began with the attempt to provide Chinese physicians for our mission hospitals. It was nurtured in the bosom of the Association and is regulated to a large extent by the Association's Council on Medical Education. Not only is this work interdenominational in supplying Chinese physicians to all Boards alike, but practically all the schools are union institutions and are examples of what union work should be.

Nurses Hospitals can no more do without nurses than they can do without doctors, and the China Medical Missionary Association has for many years pled that the Church at home take full cognisance of this. But foreign nurses are not enough. As China requires a medical profession so she also needs a nursing profession. To meet this, and directly from the Association's work, there sprang into being the Nurses' Association of China, now a separate but very closely allied organization doing splendid work in training Chinese nurses.

Hospital Technicians The latest work of the Association, and only now being organized, is an attempt to meet the needs of medical missions of all denominations with a supply of trained men for special departments of hospital work. The impossibility of getting fully trained doctors, for mission hospitals in sufficient numbers, either foreign or Chinese, is becoming painfully apparent and something must be done to help the physicians working alone. Our proposal is to train intelligent young men and women by a comparatively short intensive course in one special branch, in which they may become proficient and then return to help the hospital doctor along that special line . . . Such special training will be in bacteriology, X-ray work, anaesthetics, pharmacy, hospital management, etc.

The China Medical Journal The Journal is circulated to members and subscribers as the organ of the Association. It helps to keep the men and women of all denominations in touch with the progress of science as it affects their special work.

Promotion of Christian Unity Denominationalism gets but short shrift among the members of our profession. When union does come, as come it must, it will be on the basis of such practical work as the members of the Association are engaged in. The collective work of the Association in part, at least, supplies this basis already.

NATIONAL SERVICE

Public Health Perhaps the most striking single example of the national service that the Association has rendered is to be found in the checking, in coöperation

with the Manchurian Plague Prevention Service, of the first epidemic of Pneumonic Plague in 1910. Fifty thousand persons lost their lives in this epidemic, but, large as this figure seems, it would have been trifling to the losses incurred if the epidemic, not checked in the North, had swept over the rest of China as in former days it doubtless would have done.

Less dramatic but none the less useful has been the steady work of the Association along public health lines, first through its own Committee and now mainly by the Council on Health Education, of which the Association is a constituent part.

It gives instruction to the people how to preserve their health and how to guard against epidemics by vaccination. It founds health centres for instruction in sanitation and other matters. It seeks to reach the mother with that training that will ensure to the coming generation a truer and cleaner outlook on life. It goes after the boys and girls in the schools to remedy their physical defects and place them in more hygienic surroundings and it is striving to find the best way of bringing health conservation to the Christian workers of all Churches and denominations.

Terminology and Publication To the Association China owes the fact that it has a scientific medical terminology. In the early days the whole of this work was done by one of our Committee, and in the final phase of an officially recognized terminology our Association has played a large part. So also with the publication of the medical books that form the basis of western medical science in China. The large bulk of these have been produced by members of the Association and published by its Committee.

Establishment of Medical Schools The beginnings of Western education in medicine was entirely in the hands of the medical missionaries and was carried on mainly by the apprenticeship style of training. The result was to produce a certain number of very capable Chinese doctors, but in the bulk such training was, and always must be, eminently unsatisfactory. The natural advance was along the lines of providing schools where

more thorough teaching could be given. A few small and poorly equipped schools began to spring up in different parts of the country, but as to staff and finance the weight was too heavy for any one body to carry. Union was already in the air and by union schemes a few strong colleges have already been established, notably the Peking Union Medical College.

Our national service in medical education has been very freely acknowledged. The control of Medical Standards in these union institutions is now largely vested in the Association's Council on Medical Education. Curricula for "approved" schools have been drawn up and may largely be accepted by Government Colleges as well as our own.

**Ethical
Standards**

It is widely known that the ethical standards of the untrained medical profession in China are painfully low, practically non-existent.

The influence of the China Medical Missionary Association is being used to its full extent to establish high standards and a Committee of the Association is working on this subject at the present time.

Research Work

China, with its wide area of country and its striking variations of climate, is the home of a multitude of pathological conditions, a few unique and many obscure. To elucidate the problems that these diseases bring a Committee of the Association has been working for many years, determining the distribution and nature of the pathological conditions and investigating the physiological standards of the Chinese, a knowledge of which must of necessity be a prime factor in all public health work and preventive medicine.

CHAPTER LXIII

NURSES' WORK IN CHINA

Cora E. Simpson

Origin Nurses' work has come to China quietly. No flourish of trumpets announced the arrival of Miss Elizabeth McKechnie (Mrs. C. H. Thomson) in 1884, as the first nurse to take up work at Margaret Williamson Hospital, West Gate, Shanghai, China. Few knew of the home coming of Miss Elsie Mowfung Chung (Mrs. Bayard Lyon) as the first Chinese nurse trained abroad (Guy's Hospital, London) and returned to her native land. Many people knew of the massacre of Dr. Eleanor Chestnut of Lien chow, Kwangtung, but few knew that she was also a graduate of the Illinois Training School for Nurses and had almost completed at the time of her death, the translation of the first text book on Nursing to be translated into the Chinese language, "Principles and Practice of Nursing", by Isabelle Hampton Robbs. The translation was later completed by Dr. Bliss Boggs and was for many years the standard text book of the Nurses Association of China.

Founder Dr. Philip Cousland the Physician, missionary, translator and writer was the "Father of the N. A. C." and its great friend and advisor.

Date of Birth The Nurses' Association was born in 1909, but little was accomplished until a meeting was called on Kuling in 1912, when representatives from different parts of China were present and broad plans for the future were mapped out for registration of schools, a uniform curriculum, national examinations and a national diploma.

Perhaps the first the public knew of the N. A. C. was when the first National Convention was held in Shanghai in 1914. At this Conference Miss Chung recommended the word for "nurse" (護士) which was adopted by the

Association and has since passed into the Chinese language. Little attention was attracted in 1915 when the N. A. C. gave its first national examinations and issued the first diplomas to successful candidates—two boys and one girl.

Journal Launched In 1920 Mrs. Hearn undertook to launch the "Quarterly Journal for Chinese Nurses". For three years Mrs. Hearn carried the Journal and won for it a place among the nurses' journals of the world.

National Convention The Nurses' National Convention was held in Hankow in January 1922. The nurses felt that the time had come when a full time secretary was needed to care for the interests of the Association. The American Methodists granted the request and released one of their nurses for the position; other missions contributed toward the expense of this forward move.

1922 was the year destined to bring the N. A. C. into the International limelight, for on May 22, of that year, the Nurses' Association of China was admitted to full membership in the International Council of Nurses with every privilege accorded to any other nation—this is the greatest honor and highest privilege that can ever be accorded to any nation in nursing.

Curriculum and Examination System The Association has a standard, uniform, national curriculum and system of examinations, issues diplomas to successful candidates, and receives its own graduates into full membership. There are now more than eighty registered schools of nursing located at different places in China. More than half of the schools are co-educational. About half use Mandarin and half the other dialects of China. Co-education has been successfully carried on by the N. A. C. for years. If young people can study nursing books together they ought to be able to study together any other subjects given in common schools. In 1915 three nurses were graduated: this year there were more than one hundred and sixty. This year also the N. A. C. became a member of the Council on Health Education for China.

National Nurses' Day Florence Nightingale's birthday, May 12th, has been adopted as National "Hospital Day" and this Day will be appropriately observed in all our Hospitals and Schools of Nursing. The motto of the Association is "service" (役): the national colors are "red and gold": the emblem is the "bamboo".

Books A fine list of books has been translated. This year also all the schools of nursing have been re-registered and are being standardized.

Nursing Education A Committee on Nursing Education has charge of all matters pertaining to the schools of nursing in the Association. The National Conference was held in Canton at the Kung Yee Medical College Jan. 31 to Feb. 6, 1924. Our nurses are in demand all over China and elsewhere. Some have taken up special lines of work such as anaesthetics, laboratory work, X-ray, baby welfare, social service and industrial nursing. In speaking of the marvelous growth of nurses' work in China during the past ten years Miss Anna Jamme, a former President of the American Nurses' Association said, "It is a record unsurpassed in the history of nursing in any country in the world."

Support We already have the loyalty and coöperation of some of the great men of China. General Feng wants only N. A. C. nurses for his army. Dr. Wu Ting Fang, at his own request, was tenderly cared for by our nurses at the Kung Yee Hospital Canton until he died. After he was nursed through a serious illness by Mrs. Chung Lyon, President Yuan Shi Kai was always the friend of the nurses. The Governor of Kwangtung paid the expenses of six of his nurses to attend the Conference held in Hankow in 1922. The Peking officials placed a special car at the services of the nurses for the same Conference. The Governor and his whole cabinet and staff attended the Conference and spoke of his appreciation of the nurses' work in his province.

One Governor said to a graduating class of nurses "When the nurses come they bring a religion we can all understand". The Master said, "He that would be great

among you is the servant of all." Truly no greater privilege has been given to mortals since the days when the Master trod the earth than has been given to the nurses of China to-day. They, like their Master, come "not to be ministered unto but to minister" and to *give* their lives.

CHAPTER LXIV

THE AMERICAN RED CROSS IN CHINA

The American Red Cross China Central Committee, 4 Quinsan Gardens, Shanghai. Telephone N. 438; Cable Address Amredeross.

Committee: The Honorable Jacob Gould Schurman, Honorary Chairman.

Judge C. S. Lobingier, Field Representative.

Major Arthur Bassett, Chairman.

Dr. J. C. McCracken, Vice-Chairman.

Dr. W. W. Peter, Honorary Secretary.

Mr. P. P. Whitham, Honorary Treasurer.

Dr. J. B. Fearn.

Mr. Carl Crow.

Mr. Julean Arnold.

Mr. J. Harold Dollar.

Mrs. Lansing Hoyt.

Miss Luella DeLamarter, Secretary.

This committee acts first as a centralizing organ for the chapters of the American Red Cross in China, which are located at Peking, Tientsin, Hankow, Chungking, Foochow, Canton, Amoy, Changsha, Hanchow, Nanking, Swatow, Tsinanfu, and Harbin. Its second function is to do the local work of a Shanghai chapter, which is not at present in existence. While the principal thought of National Headquarters in maintaining a China Central Committee is that the American Red Cross in China shall coöperate with the Chinese Red Cross until it is established on a firm foundation, there is much local work to be done among foreigners, for which a permanent organization will undoubtedly be maintained indefinitely. Shanghai membership in the American Red Cross has grown from 85 in 1919 to 958 (Roll Call, November, 1923).

Besides the routine work, which consists principally of administering local relief to destitute Americans (financed by the American Community through the

American Association), the China Central Committee has afforded relief during the past year and a half in the following ways:

American Relief Administration The China Central Committee assisted 179 Russian residents of Shanghai to send food and clothing to destitute relatives in Russia through the American Relief Administration in New York. The total amount of money sent by the China Central Committee was U.S. \$9,826.86.

The Swatow Disaster On August 8th, 1922, the China Central Committee sent Doctor and Mrs. M. O. Pfister to Swatow for relief work. Altogether a total of Mex. \$12,515.55 was made available by the China Central Committee and the China Chapters for Swatow relief work.

Russian Refugee Relief The American Red Cross, through the China Central Committee, has spent G. \$30,000 on the relief of Russian refugees in China. The greater part of this relief has been carried on in Manchuria under the direction of Mr. W. Morgan Palmer, formerly of the Salt Gabelle in Manchuria; but nearly M. \$7,000 was allocated to use in Shanghai and was spent on the maintenance of a soup kitchen in the Hongkew district and on medical relief at the Shanghai General Hospital.

Relief of Captives at Lincheng On hearing of the capture of foreigners by Chinese bandits at Lincheng on May 6, 1923, Mr. Carl Crow, as the representative of the China Central Committee, went to Lincheng to take relief to the foreigners. He supplied the captives with medicine, food, clothing, beds, and other provisions asked for. The China Central Committee was authorized by Washington headquarters to expend up to U.S. \$2,000 on this relief work, but the deficit which the Red Cross eventually met was M. \$2,813.65.

Japan Relief On September 8th, 1923, in response to an appeal from the American Consul in Kobe the China Central Committee sent a unit of four doctors, eleven nurses and one orderly to Kobe. This unit was under the direction of Dr. M. B. Miller of Philadelphia, and was accompanied by Dr. W. W. Peter of the China

Central Committee. The unit established itself in the Oriental Hotel, Kobe, and gave medical care to the 330 foreign refugees who needed it when they arrived in Kobe from Yokohama and Tokyo. The China Central Committee also assisted in, making a survey of provisions that could be purchased in Shanghai and in shipping them to Japan. Contributions for Japan relief from all the China Chapters of the American Red Cross were received by the Committee and forwarded to Washington. Altogether the American National Red Cross spent over ten and a half million gold dollars on Japan relief. Large purchases of rice, flour, lumber, corrugated iron, medical and hospital supplies, disinfectants, clothing, underclothing, socks and simple necessities were made in the United States and shipped to Japan.

**Seventh
Annual
Roll Call**

On November 20th, 21st and 22nd, 1923, the Seventh Annual Roll Call was made in Shanghai under the direction of Mrs. Gardner Crane. Mrs. Crane enlisted the services of a number of members of the American Woman's Club, and the drive resulted in an enrollment of 958 members, as against 85 in 1919, 81 in 1920, 479 in 1921, and 583 in 1922.

Simultaneously with the Seventh Annual Roll Call Junior Red Cross membership was inaugurated in the Shanghai American School, a hundred percent enrollment being made.

Civilian Relief

The daily routine work of the China Central Committee consists largely of the administration of civilian relief which, since July 27th, 1922, has been financed almost wholly by the Shanghai American Association. All American seamen or other persons recommended to the Committee by the American Consulate are helped without further investigation. Other cases are investigated and passed on by the Committee. The largest expenditures are those for sending destitute Americans back to the United States. Relief is not afforded exclusively to Americans, however, and the office of the China Central Committee daily has visitors of many nationalities applying for various kinds of assistance, chiefly clothing.

CHAPTER LXV

KULING MEDICAL MISSION

Calvin E. Buswell

The Kuling Medical Mission is unique in many respects. It includes four departments:—Educational, Evangelistic, Welfare, and Medical.

History Following the opening of Kuling to foreign residents in 1896, a small mission work was started to care for the physical and spiritual needs of the Chinese community which rapidly built up just outside the entrance to the Kuling Estate.

In 1902 the Kuling Medical Mission was organized for the purpose of caring for the sick, and of conducting regular evangelistic work among the thousands of Chinese who went there to administer to the various needs of the foreign community. The work at first was carried on in rented premises and with very scanty equipment. It was not until 1904 that there was a foreign physician in permanent residence on Kuling.

Together with the growth of the foreign settlement, the Medical Mission grew and prospered, and in 1909 land was purchased on which three years later a building was erected with accommodations for a chapel, a dispensary, and for about twenty men patients. At that time a day school was conducted in a building opposite the hospital, which also had been purchased by the Medical Mission. Almost the entire cost of this development was covered by subscriptions on Kuling.

A few years later another piece of property was secured for a Women's Hospital, and in 1920 a building was erected on this site as a memorial to the late (Mrs.) Leila Berkin, M.D. who personally planned and carried on the work for the first ten years of the Kuling Medical Mission.

Since the coming of Dr. and Mrs. Venable in 1919 the work of the hospital has grown until it has exceeded all expectations. New property has recently been purchased for men patients, and as this is now full to overflowing there is still need of more accommodation.

Organization The Kuling Medical Mission is under the control of a Board of Managers appointed jointly by the Kuling Estate Council, the Kuling Union Church, and the Kuling Medical Missionary Association.

Support The Kuling churches devote one Sunday each year to the subject of Medical Missions, and the collections taken on that day go to the support of the Kuling Medical Mission. The salary of Dr. and Mrs. Venable is paid by the American Presbyterian Mission, South, and the salary of Dr. and Mrs. Buswell is paid by the American Presbyterian Mission, North. Several other missions contribute smaller amounts, and contributions are received from individuals from time to time.

Education A Christian primary day school is conducted on premises owned by the Medical Mission, and has an attendance of between seventy and eighty pupils throughout the winter.

Evangelism The Chinese Church holds regular Sunday and week day services in the hospital chapel throughout the year. A Sunday School has recently been organized, and is well attended. Itinerating trips are undertaken from time to time, when visits are made in some of the villages in the foot hills.

Welfare A Coolie Shelter is conducted under the auspices of the Kuling Medical Mission, which furnishes sleeping accommodations free of charge to many poor Chinese who come to Kuling for work or other reasons.

Medical A dispensary is open every day except Sundays throughout the entire year, and a small pharmacy is also open daily for the sale of medicines. A limited number of beds are reserved in the old hospital building for the care of non-tuberculous patients.

The great majority of those treated in the hospital are tuberculous patients. For these it is aimed to accomplish three things:—

First, to use all of the available means to assist the patients in recovering their health.

Second, to instruct the patients in the proper care of their health so that after leaving the hospital they may be able intelligently to carry on their work and at the same time to conserve their strength and thus avoid a recurrence of the disease.

Third, to surround all of the patients with a definitely Christian atmosphere, that those who are not Christians may come to know and accept Christ, and that those who are Christians may grow in their spiritual lives while they are recovering their health.

Kuling is becoming more and more recognized as a health resort, particularly for the treatment of tuberculosis, as is shown by the fact that last year patients came to the Kuling Medical Mission from fourteen provinces of China.

The patients who come to the Tuberculosis Sanitarium are almost without exception educated men and women, and about two thirds of them are Christians. Many of them are valued and highly trained Christian workers who have broken down with tuberculosis and who after spending from six months to a year or more on Kuling, are able to return to their work.

PART IX

SOCIAL AND INDUSTRIAL PROBLEMS

CHAPTER LXVI

PRESENT INDUSTRIAL OPPORTUNITY

BEFORE THE CHURCH

Wei Tsung Zung

It is no longer to be doubted whether or not modern industrialism has come to China for it is here. It is an imported innovation, but unlike an imported institution it is not marked by its twentieth century freshness and characteristics. Instead it assumes the unwelcome form recognizable only by eighteenth century witnesses. Modern industry in its present state cannot very well fulfill its purpose, it cannot to any appreciable extent render its service to society. In fact, because of its existence, society has more problems to face than ever before.

But the problems in this connection are not insurmountable. Although industrially China has made a bad beginning, still she is in the advantageous position of being able to learn from the West. In this early stage, if industrial questions are properly handled, China may yet avoid those mistakes which mar the civilization of the industrial West.

Many seem to be aware of the situation but none were interested to seek constructive ways to face it until the Church came forward to take a definite stand. On May 10, 1922, when the National Christian Conference was held in Shanghai, a minimum labor standard was unanimously endorsed as follows:

Chinese Church
And Labor

“ The Church, recognizing the need for a labor standard for China, endorses the setting as a goal of the standard adopted at the First International Labor Conference of the League of Nations, but

“In view of the difficulty of immediate application of this standard to the industrial situation in China, it urges that the following standard be adopted and promoted by the Church for application now:—

- “ a. No employment of children under 12 full years of age.
- b. One day’s rest in seven.
- c. The safeguarding of the health of workers, e.g., limiting working hours, improvement of sanitary conditions, installation of safety devices.”

After the Conference and before the official organization of the National Christian Council, the Committee on the Church and Economic and Industrial Problems which prepared the original report, carried on the work till May, 1923. The work of the year, May, 1922 to May, 1923, may be summarized by quoting a few passages in the report of the said Committee submitted to the First Annual Conference of the National Christian Council in May, 1923 as follows:

Industrial Conference “In September, hearing of the proposed visit of Dr. Sherwood Eddy, this Committee got into touch with him and asked him to include the promotion of its aims in his work while in China. The next step which grew out of this quickening of interest in the local communities was the calling of a small industrial conference, which assembled 43 delegates from 8 of the largest industrial cities, for two days of conference in Shanghai early in December. Out of this December Conference came the following results:

1. The Industrial Committee was enlarged, and Dr. Frank Rawlinson, Mr. M. T. Tehou and Miss Wei Tsung Zung gave part time work as a secretariat for the committee.
2. Industrial church groups have been organized in Canton, Changsha, Chefoo, Foochow, Hangehow, Nanking, Peking, Shanghai, Tientsin, Tsinan and Wuchang.

3. To meet the growing number of requests for information, counsel, etc. which began at once to pour in to the central committee, a carefully planned series of leaflets, bulletins and letters have been sent out to a large mailing list.
4. The travel of all such people as could directly represent the committee has been utilized to the full.
5. Action taken in individual cities includes the following:—The church labor standard has been officially endorsed by: the boards of directors of the Tientsin and Chefoo Y. M. C. A.'s, the National Committee and local boards of the Y. W. C. A. in Shanghai, Tientsin and Peking, the Kiangsu Synod of the Episcopal Church, and the Chinese Chamber of Commerce of Chefoo and Peking. The Chefoo industrial group has made a distinct move forward in coöperation with the employers; in Peking one section of the group is watching the new factory legislation and has been asked by the Ministry of Agriculture and Commerce to advise and make suggestions to them; and Shanghai is working on the problem of child labor and questions of industrial hygiene and a living wage and has actively helped the new child labor commission appointed by the Municipal Council to study the question."

In May, 1923, the National Christian Council appointed a Commission on Church and Industry to carry on permanently the work that had been done by the Committee on The Church and Economic and Industrial Problems.

*This Commission, on September 11, 1923, recommended a policy and programme to the Executive Committee of the Council which was adopted and endorsed. The gist of the Policy and Programme may be summed up in the following paragraphs:

"That the National Christian Council utilize every effort at its disposal to promote the three standards adopted

*See The Chinese Social and Political Science Review, October, 1923, "Modern Industry in China" by W. T. Zung.

by the National Christian Conference in May 1922, to coordinate activities of various organizations in local centers for bettering industrial and social conditions or relationships; to give advice to those centers where experiments are being made for working toward a better social order; and to take immediate steps toward establishing a center or centers for social and industrial research.

"Some definite methods are proposed to carry out the above lines of service, such as conferences in various places, preparation of literature, visits to special centers, institutes or summer schools, and courses of lectures. From time to time foreign specialists will be brought to China to examine into and report on special conditions and problems, and in other ways to render expert help as the occasion demands and opportunity offers. In order to equip China with specialists in this field, chances should be given to promising students for technical training either in China or abroad."

A cabinet of six was appointed by the National Christian Council to carry out the work planned by the Commission on Church and Industry. The six people are Dr. H. T. Hodgkin, Dr. Frank Rawlinson, Mr. Gideon Chen, Miss Mary Dingman, Mr. M. T. Tchou and Miss Zung Wei Tsung who met three times a week. Miss Agatha Harrison was a member of this cabinet until her return home. In October, 1923, the National Christian Council sent a "Message" to all the national Christian organizations for coöperation in a unified effort to secure a Christian industrial order. To quote the last sentence of the "Message": "In order, therefore, to achieve a united Christian approach to this task it is urged that all Christian organizations, in developing an industrial policy, will look to the Commission on the Church and Industry appointed by the National Christian Council, to secure adequate unification of policy and effort."

**Dame Adelaide
Anderson in
China**

At the invitation of the National Christian Council Dame Adelaide Anderson, late Chief Lady Inspector of Factories of Great Britain, came to China in December, 1923. As Dame Adelaide has given nearly thirty years' service to her government in factory inspection it is most fortunate that

China at this opportune time should be able to secure her help and advice on various phases of industrial work.

The preceding paragraphs give a bird's-eye view of the work done by the National Christian Council through the industrial committees since May, 1922. It is gratifying to note how steadily—though slowly—the church has taken each step for promoting the idea of Christianizing industry in China.

**Chinese
Church
Confronts
Problem**

But on the other hand, if the Christian Church itself is considered in the objective we instantly find that it is confronting more problems than we casually think. In the first place, the attitude of mind on the part of the great majority of people that constitute the church makes the task difficult. To many honest and good Christians, individual salvation will always be *the* most important thing in Christianity, not to be subordinated to society which is but the combination of individuals.

In the second place, a very small percentage in the Church is informed on the industrial problem. Owing to the lack of scientific research, those who pretend to know a little find dissatisfaction in this lack of authority.

Lastly, the Church, in the position of an employer, needs to learn just as much as any industrial employer the ways to fulfil its own pledge regarding the labor standard. In erecting mission buildings, the Church should see whether or not the work is done according to these standards. In employing Bible women and village pastors the church should be sure that they are paid a "living salary." Can the Church expect non-Christian employers to do the ideal thing while it neglects its own duty?

But the few problems that are facing the church to-day are certainly not formidable enough to warrant pessimism or discouragement. Modern industrialism in China is comparatively recent and its evils are not yet deep-rooted. And moreover, despite the fact that the Church itself is far from being perfect, it has made it its chief concern to see that this progress of the evil industrial system be stopped before it has gone too far. If the Church stands for love and justice, the Fatherhood of God, and the Brotherhood of man, it must utilize every

opportunity and spare no effort in finding ways to face its own problems and to overcome all difficulties in helping solve the industrial problems of China. If the Chinese Church determines to move forward in the right direction China will yet see the day when modern industry really fulfils its mission—to serve humanity.

CHAPTER LXVII

CHRISTIAN INDUSTRIAL ENTERPRISES

Lily K. Haass

Handwork as a method of self support for needy women, and more especially for girls in schools, has been used by missionary workers for over twenty years. It is only within the last three years, however, that large numbers of industries have been started for the purpose of relieving poverty. The famine of 1920-21 gave a great impetus to the movement. They are scattered throughout all China but are most numerous in central and northern China, where an incomplete survey shows a list of thirty-two. Practically all of them were instituted for charitable purposes, or as a means of general social Christian development. One, the Shaohsing Industrial Mission, was started to provide a substitute for the making of spirit money which seemed to be the only work available for both Christians and non-Christians. Some have at least as a subsidiary aim the making of money to use for general missionary purposes,—kindergartens, hospital beds, etc.

Management Except in cases where the industry is connected with a school, as a self-help department, the industries are with one or two exceptions, under private management. Missionary wives, who have had to face many cases of need, have taken the lead; evangelistic workers and teachers also conduct industries. A few, notably the Anking Cross Stitch and the project at Ku Lou Hsi, Peking, have made considerable progress in shop committees. Only one reported work started and managed by a group of Chinese women. There are, to be sure, industries initiated and run by Chinese women entirely, but more largely as private business enterprises than for social purposes.

The Workers Twenty-six industries reported a total of 1600 workers, or an average of about sixty. The largest number in any one industry is 200; the smallest less than ten. The greater part of these are women. Very few children under fourteen are employed, except where children are earning their way in schools. Such work is not really to be classed under industrial enterprises. Some girls under eighteen are employed, but usually they spend half a day or a fair number of hours in study. Some of the women are beggars taken off the street, and can never become skilled; others had a fair degree of skill before entering.

Types of Work Needle work of all varieties, with an especially strong emphasis on cross-stitch and embroidery, seems to be the chief kinds of work. The reason for this is evident; it does not require a large outlay for machinery and other equipment, and it is a kind of work the founders understand.

Working Hours Where the work is done in the work-shop, nine hours per day is the limit; eight hours is the general average, and six hours in work involving eye-strain. Some work is done at home, so that it is difficult to limit the hours. The managers, however, recognize the dangers of sweat-shop work, and are trying not to give out more work than can be done in a reasonable number of hours. Many women cannot leave their families to go to work, and others live too far away, so that it is not always feasible to stop home work, especially when facing cases of great need.

Finances Wages run from \$2.50 to \$12.00 per week, with an average of about \$4.00. A number state that this is a good living wage in their part of the country. Seventeen industries report a total annual turn-over of \$82,794, or an average of \$4,811. They run from \$315, as the lowest, to \$22,000 as the highest. Several are working toward a sound financial basis, by laying by a reserve fund or buying property for work rooms. Except in one or two cases, no allowance is made for managerial salaries of foreigners. Profits are being used: 1. For the workers in the form of (a) higher

wages or bonuses; (b) welfare work. 2. For enlarging the business. 3. For educational or social work not directly affecting the workers, sometimes in connection with the mission.

Welfare and Religious Work Great emphasis is put on learning to read; many are using the phonetic script. Most industries have daily prayers and bible classes. Others provide opportunity for attendance upon religious services without compulsion. Some have Bible women who go to the homes of the workers. More recent are the health movements, with visiting nurses and examination of workers by doctors, with medical care. One progressive industry has health and maternity benefit funds. Free baths are provided in a number of places. Some assume very little responsibility for the children of the workers; others have day nurseries for the babies, in connection with the work rooms, and see that the older children go to school.

Market Products are sold both in China and abroad, chiefly in China. Problems of customs duty and selling agents have proved great deterrents to business abroad. In several of the larger cities exchange shops have been established to handle the goods; whether sold abroad or in China, the goods are made largely for foreign consumption. The problem has not yet been solved of making articles for which there will be a large market among Chinese. Art products of different nationalities are in great demand. Some industries are interested in the revival of beautiful old Chinese designs.

In October a conference on mission industrial work was held in Peking, and the National Christian Industries' Association was formed. Committees of this organization will investigate markets, methods of evangelistic and welfare work, wages and conditions of work. Among the findings of the conference were the following:

“That each industry represented in this Association be urged to send a special report every year to the National Association, indicating the progress of the industry toward ideal conditions along the following lines:—

1. Working day.

Eight hours a day, six for fine work involving eye strain. That the amount of home work be based approximately on the foregoing hours.

2. Shop conditions.

Lighting, heating, ventilation (120 cu. ft. approximately, allowed for each person), seating, working apparatus, sanitation.

3. Wages.

“That the Association recognize its duty to pay a living wage, and to find what is a living wage.”

Christian industrial enterprises present the great opportunity of demonstrating that industry can be run according to Christian principles. Without realizing it we have launched out in a project that must be far-reaching in its consequences.

A PARTIAL LIST OF CHRISTIAN INDUSTRIAL ENTERPRISES

Shaohsing Industrial Mission	Shaohsing, Chekiang
Moka Garden Embroidery Mission	Soochow, Kiangsu
Miss Bearder, Anglican Mission,	Peking, Chihli
Miss Gowans, Presbyterian Mission	Peking, Chihli
Miss Berg, American Church Mission	Wusih
Hsi Ku Industry, American Board Mission	Tientsin
Mrs. Fred Pyke, Methodist Mission	Taianfu
Miss Berdice Lawrence, Methodist Mission	Changli
Baldwin School Self Help Department	Nanchang
School of Many Friends	Lintsung, Shantung
Mrs. V. P. Eastman, American Board Mission	Lintsung, Shantung
Miss Lucy Savage	Kaifeng, Honan
Mrs. G. E. Molony, Church Missionary Society	Ningpo
Miss Isabelle Phelps, American Board Mission	Paotingfu
Blind Girls' Industrial Home	Mukden
Mrs. C. W. Troxel	Tungchangfu

Peking Exchange	Peking
Mrs. Hallie Cline	Kaifeng
Mrs. George Davis, Methodist Mission	Peking
Mabel Huggins, American Board Mission	Techow
Mrs. Theodore Bliss, American Church Mission	Wuchang
Miss Ellen Nielsen	Ta Kushan
St. Agnes School, American Church Mission	Anking
Mrs. Charles Reid, American Church Mission	Anking
Katherine Phelps	Anking
Yale Mission Cross Stitch	Changsha
Anking Cross Stitch, American Church Mission	Anking
Ku Lou Hsi Kung Ch'ang, Presbyterian Mission	Peking
Peking University	Peking
Mrs. F. H. Crumpacker	Shansi
Women's Industrial School L. M. S.	Tingchou, Fukien
Miss Huggins, American Board Mission	Tungchou, Chihli

CHAPTER LXVIII

OPIUM AND NARCOTICS

W. H. Graham Aspland

China during the year 1923 cannot have produced much less than 10,000 tons of opium, which is equivalent to about 3 times the product of the entire world, and in spite of cabinet telegrams to the governors of provinces ordering suppression, planting of poppy for 1924, is even more extensive. Whilst the Central Government has declared to the world its opposition to monopoly or re-legalization in any form, at least 8 provinces have established partial or complete monopolies under military and civil authorities. Smuggling combines on a gigantic scale, working with official connivance, are known in many parts of the land. Heavy taxation on poppy land, transit taxes, taxes for sales, permits, opium smoking den licences, and taxes on individual pipes in these dens, together with heavy fines on those attempting traffic in opium independent of the combine or the local monopoly, make up the sources of revenue to support military campaigns, or fill the coffers of those fighting for personal political ends.

Monopolies Monopolies have engraved stamps for transit and duty stamps. Land is taxed thirty to forty times the amount of five years ago, and compulsorily collected for two and three years ahead under penalty of confiscation and imprisonment. Opium must be grown, for no other crop would yield the tax, and in some parts opium is so plentiful that the people finding it impossible to export to neighboring provinces, where it is equally plentiful, have taken to using it as a general habit. Churches, missions, district boards, local association, guilds and private individuals have protested in large numbers and apparently with little result. Unless something drastic is done 1924 will exceed 1923 in every way. Not a province in China is free from either general

cultivation or general use, except the model province of Shansi under the Model Governor Yen Hsi-shan, where the latest report shows a 90% total suppression in every form.

Shansi is a convincing proof that, with only a few specific limitations, the affairs of any province are in the hands of the Governor providing his province is free from war. Militarism and opium are undeniably interdependent wherever there are interprovincial conflicts, but the Governor of a province at peace, must accept the total responsibility for opium use and production. If it is not suppressed it is because he wishes to raise funds either for himself or for his political enterprises.

The defense of the Central Government for the recrudescence of the last five years has been that opium was grown in provinces over which the Government had no control; this is no longer a fact for Kansu, Shensi, Honan, Anhwei, Hunan and Fukien, owing allegiance to the Central Government, are either extensively cultivating it, or have adopted its general use under taxation.

Review of the Provinces All the statements following are extracts from reports of foreign missionaries in the provinces named:

Yunnan The worst opium province in China. Poppy is in bloom everywhere. Opium smoking fumes are in every street. Eight or nine persons out of ten smoke opium. Taxes of \$40 to \$50 per 100 ounces of opium are imposed. An Opium Combine with a capital of \$1,000,000 endeavored to export this year 400 tons of opium to north China by way of Tonkin. International action stopped the export, but only after 150 tons had gone.

Kweichow Practically the whole of this province is given over to poppy, and the people have for several years suffered from famine as the result of insufficient land to grow cereals. Large convoys of opium under military guards were sent north during 1923 to Hanyang and Hankow, for the purchase of arms and ammunition.

Szechwan Opium smoking is worse than in the days of the Manchus. Two-thirds of the land is given over to poppy. A missionary writes, "itinerating in my

hsien over a distance of 50 English miles, it was a rare sight during harvest to see any one doing other than gather opium.'

Hunan West and south, poppy everywhere. Opium a dollar an ounce. It is found in every home except those of Christians. For the past two years 70 to 100 cartloads pass every week through Liang Tow Tang escorted by government soldiers en route for Hankow. In Lungshan even young men and boys are smoking. I counted on one day 400 coolies carrying opium loads accompanied by 180 soldiers. The opium traffic is very prosperous. At Hung Chiang whole fleets each of several hundred Miao boats are bringing down the drug from Kweichow. At Yungwei opium is sold at \$9 a ching (between 21-22 ounces). In Shenchowfu people of all classes are smoking or eating it.

Anhwei This province illustrates the financial results of opium taxation. In Fu Yang Hsien, which has 18 districts, the taxes were imposed and collected by the civil and military administration. Chinese members of our branch Anti-Opium Association were frequently prevented by armed soldiers from taking photographs of poppy fields. The Branch report of their investigation covers nearly 400 pages, and shows unprecedented cultivation and oppressive taxation.

List of Fu Yang Hsien districts with amount of opium taxation during 1923.

City District	\$10,000
East District 1st	24,000
East District 2nd	10,000
East District 3rd	48,000
West District 1st	54,000
West District 2nd	21,000
West District 3rd	48,000
West District 4th	34,000
West District 5th	28,000
South District 1st	40,000
South District 2nd	44,000
Southwest District	46,000
Southeast District	10,000
North District 1st	16,000

North District 2nd	42,000
North District 4th...	66,000
Northwest District	20,000
East Village 1st	2,880
Total	<u>\$563,880</u>

If this be the result of one *hsien* what will be the total for the Province?

Kansu Prices of food stuffs have advanced fifty per cent. Chung Wei Valley is almost one great opium field this year. As far as the eye can reach nothing is seen but poppy flowers. The crop is so extensive that men enough to harvest it are not available. In ordinary years the fields now in opium have borne large crops of rice, wheat, millet, beans, and potatoes. This year there will be very little of these necessary food crops.

Hupsh Some opium is grown, but the chief evil is the big smuggling transactions along the river principally at Ichang and Hankow.

Ichang reports:—To-day 150 coolie loads of opium amounting to between 6 and 7 tons passed in lighters under military escort to Wuchang to pay for military stores. The opium season is in full swing, large quantities are being smuggled through this port. During June the Customs made no less than 40 seizures varying respectively from 600 to over 4,000 lbs. Opium is sold at \$2 per ounce.

Hankow Custom's report says, "during the year we have seized 16,226 lbs. but what is thus detected represents an infinitesimal proportion of what evades detection and passes through or is consumed in the district."

Fukien Conditions desperate. Land taxed \$10 per *mu*. Opium cultivation compulsory. Refusal means imprisonment. Petitions during the year have been sent to the International Anti-Opium Association and by them forwarded to the Chinese Foreign Office, the League of Nations, and the U. S. A. and British Ministers, from The Church Missionary Society,
The American Methodist Episcopal Mission,
The English Presbyterian Mission,

The London Missionary Society,

The Fukien Branch of International Anti-Opium Association, and many individual missionaries.

Bishop Hind wired November 1923:—Fukien opium situation everywhere urgent. Military and naval authorities enforce cultivation. People opposed but powerless. Urge strong immediate action.

Fukien Anti-Opium Association has petitioned the Foreign Consuls of Foochow, pointing out that the military authorities were endeavoring to raise \$15,000,000 by opium taxes in five districts of South Fukien.

The sowing of poppy for 1924 harvest is greater than that of 1923.

Kiangsi One of the most daring monopolies exists in this province at Lung Yen under the title of "Opium Investigation Bureau." The following are its regulations:—

1. Opium tax \$12 per *mu* and \$5 extra for poppy seeds.
2. Five tenths of the total field area must be devoted to poppy cultivation.
3. Every planter must be registered.
4. Fines will be imposed if any area fails to devote as many *mu* to opium cultivation as demanded by Art. 2.
5. Secret planting will be punished by a twentyfold fine and confiscation of land.
6. The head of the Bureau will be rewarded 10 cts. a *mu* according to his efforts.

Police reports state that there are 800 opium dens in Hsueh Chow paying a tax of \$5 a lamp.

Shensi One of the worst provinces in China. Opium is selling at 35 cents an ounce. Practically the whole province under cultivation. Opium selling is an open business. Wei Nan reports 20 opium dens in a single street, all hanging out attractive sign-boards. On a three days' missionary journey from Han Chung in June 1923 poppy was not lost to sight the whole way. Similar reports from many other districts. To-day (Dec. 6, 1923) General Li Kai-hsien Opium Investigating Commissioner has reported to the Government that

poppy cultivation has been completely suppressed. It always is in the winter. Why further insult our intelligence!

Manchuria Opium is legalized at Shui Fen Ho. The stamp tax is \$10 per pound. About 100,000 *mu* in Kirin district along the sides of the Eastern Railway were planted with poppy this year. Land taxes for opium growing are paid in opium not cash, except where soldiers or brigands seize the whole crop.

Jehol For the last two years Jehol opium has been cheaper than any other variety in Peking. Military smuggling has been very extensive. A September report says "6,000 lbs. of opium ready for military transport." 450 lbs. under military escort were seized at the gates of Peking in September. Owing to remoteness and brigandage the opium investigating Commissioner found it almost impossible to conduct his investigation.

Shiyuan No poppy grown, but an alarming traffic under taxation, carried on with Kansu and Shensi. Even children of 10 years as well as women and men have become the pitiable victims of the smoking habit.

Honan Poppy is being extensively planted this winter (1923-1924). A November report says, "In all this region (southwest) poppy production has never been seriously checked. It is now rampant. It is responsible for brigandage. Most of the operations of Lao Yang-jen during the last three months have been looting opium. The average tax is \$10 per *mu*. Every package of opium in shops is taxed and stamped on pain of confiscation and fine. South and southeast of Honan is in same condition."

Kwangtung A missionary writes from Swatow, "During my thirty odd years in China I have not seen the cultivation of the opium poppy carried on to such an extent as at present. I am informed too that not only are people (farmers) encouraged to grow the poppy but are supplied with seed and in some cases compelled to sow, otherwise threatened with penalties."

Another from a District near Canton "Large quantities of opium are carried over land from Kweichow and Yünnan. Opium smoking has increased in the past two years, and opium is about half the price it was a year ago. Much of the opium traffic in Kwangtung is due to military occupation. Taxation and licensing has been enforced to raise funds."

Other provinces have not been dealt with in detail in order to keep this review within limits. Sufficient has been written to show that the country is almost back to the old days before prohibition, but with this added regret that it is now absolutely contrary to law, and that it is hourly lowering the prestige of China because of her breach of foreign treaties.

Shansi-the Glorious Exception As already stated this model province has already eradicated 90% of its opium and narcotic evil, and were it not for Shensi and Honan on its borders, the remaining 10% would long ago have been wiped out. No poppy is grown in this province. Out of the 105 *hsiens* in the province 98 have Anti-Opium Societies under the direction of the Magistrate. A large number of centers have been opened for curing the habit. Over 51,000 persons have been treated during the last two years, 3,000 persons have been punished as dealers, and 15,000 arrested as smokers. During 1922 nearly 40,000 ounces of morphia and opium, a quarter of a million Chintan pills, and 18,000 opium lamps and pipes were seized and burnt.

Governor Yen has recently sent protests to the Governor of Honan and Shensi, regretting that he cannot clear his province, so long as his neighbors allow cultivation.

Morphia and Narcotic Drugs Under this heading 1923 shows an apparent improvement over 1922. This may be accounted for in two ways. First the increasing control and diminishing manufacture by Western nations and secondly that China has abundant cheap opium and freedom of use so that morphia is not demanded.

During 1923 not an ounce of British or American narcotics has been seized in China.

Japan shows evidence of fulfilling her obligations to the League of Nations and judging by her official reports her manufacture and imports of morphia and heroin which were 35,000 lbs. in 1921 are only about 7,000 lbs. for 1922. There is nevertheless much mystery concerning the disposal of these large quantities, for her official exports in 1921 were only 12,000 lbs and in 1922 less than 15 lbs. The Japanese Delegate at the League of Nations stated that the balance remained in bond in Japan. Was his information complete? In 1922 over 28,000 ounces of narcotics were seized in Shanghai and Tientsin on 24 Japanese steamers though it must be admitted over two-thirds of this amount came from Europe. The largest seizure included in the above was that in December 1922 when 17,920 ounces of heroin labelled "aspirin" and manufactured in Germany, was seized in Shanghai on a Japanese steamer.

As a further contrast we note that during the September quarter of 1922 over 4,000 ounces of narcotics were seized in Shanghai, whilst for the corresponding quarter in 1923 only one quarter of an ounce.

Adding the Customs seizures of 1922 to the 30,000 ounces of narcotics seized and burnt by Governor Yen of Shansi, and 18,000 seized and burnt in Peking, we can account for approximately 80,000 ounces, but as we have long maintained this should be multiplied by ten in order to represent the undetected bulk.

China has intimated in the press to-day (December, 1923) that she will inaugurate a Conference with Japan for the discussion of the morphia problem, and coöperative measures for suppressing traffic. This Conference was suggested at the League of Nations Session in June 1923.

A Special Conference is called by the League for 1924 of all the powers having Far Eastern possessions to discuss problems relating to the foreign monopolies of the East, and to advise and assist China in dealing with her home conditions. The anticipated results from this and successive Conferences are so hopeful that Sir John Jordan said concerning the League Session at which this was decided

China and
Japan Morphia
Conference

China, and the
League of
Nations

“Decisions have been made which I never expected during my life time.”

The International Anti-Opium Association forwarded to the League a series of beneficial reasons why this Conference should meet in Shanghai, but the League has decided that the first meeting shall be in Geneva.

Concerning the Eastern Monopolies the chief points presented for discussion by the resolution of the British Government delegate are as follows:—

1. All opium farms to be abolished, and the import, preparation and sale be to entirely in the hands of the Monopoly Government.

2. Retailers to be government servants on fixed salaries, so as to remove the temptation to push sales.

3. To fix a maximum yearly amount of opium in each monopoly at a rate of x ounces per 1,000 Chinese males, and importation to be restricted to this amount.

4. To discuss the registration of all smokers and the introduction of licences.

5. To fix a uniform selling price of opium, and uniform penalties for infraction of the opium laws in all monopolies.

We are not greatly stirred just now by the conditions in the eastern monopolies. At most there are only about seven millions of Chinese in all the foreign Eastern possessions, and whilst we hope and work for opium suppression in these possessions, we cannot forget that five times this number are being degraded in a single province in China.

Chinese National Attitude The attitude of China as a whole is difficult to define. If, however, China be divided into three general classes, namely officials, merchants and people, the attitude of either class is capable of demonstration.

Officials They are officially against opium, whilst large numbers are personally addicted to it. It is no use mincing matters. Many of the recent government telegrams sent out to governors of provinces, and re-issued by them to subordinate officials, urging drastic measures for opium suppression, are tainted in the hands of the very men promulgating them. Peking high officials,

members of parliament, police administrators, tuchuns, civil governors, and generals are known to be opium smokers, and the thoughtful public are not deceived by these official declarations. Many officials who do not personally use it nevertheless have not hesitated to raise immense funds by its cultivation and taxation. One is driven by the *prima facie* evidence of missionary reports from all the provinces in China to say officials as a class are in favor of opium. There are a few very notable exceptions.

Merchants As a whole they are indifferent, the exception being that section of them engaged in the traffic. This section however is not a large one for the traffic is almost exclusively under military or civil government control, except where commercial combines have been permitted upon payment of a large sum to the licensing authorities.

People *The Chinese Christians are against opium,* but the others give no evidence. The hundreds of protests sent to the International Anti-Opium Association during 1923 only in rare instances primarily refer to the degrading effect of opium. They are mostly concerned with the burden of unjust land taxation and compulsory opium cultivation. It would pay them better to grow cereals under the former land tax, and a market would be found for their produce. With practically a free use of opium throughout China, the number of addicts must be phenomenally large, and these added to the hordes who profit by its sale, whether in shops or smoking dens must represent an opinion in favour of opium which is greater than the moral protest of those against it. It ought not to be so.

International Anti-Opium Association The International Anti-Opium Association has had a phenomenally busy year of publicity and protest. The collection of materials for the League of Nations; protests to the ministers of nations whose narcotics are seized in China; forwarding copies of all reports on China conditions to the Chinese and Foreign Governments and League of Nations; the publication of bulletins, and the Anti-Opium Supplement; and the sending out of information to the

Chinese and foreign press, suggest a few of their activities. Twice during 1923 a questionnaire was sent to the missionaries in all provinces for reports on local conditions; these have been embodied in larger reports to governments and the League of Nations. During 1923 an investigation has been made into the use of narcotics in 100 of the large mission hospitals of China. The results have been tabulated for the estimation of the amount of morphia and cocaine required for medical purposes in China in order to meet the requirements of the import licencing certificate of the League of Nations. This Association has been dealing with the world aspect of the traffic, although its 20 branches in large cities, and scores of sub-branches in smaller towns have carried on local propaganda.

CHAPTER LXIX

FAMINE RELIEF WORK 1921-22

Y. S. Djang

To meet the need caused by failure of crops due to flood or drought in no less than 12 provinces during the second half of 1921 and the spring and summer of 1922, a sum of approximately \$3,500,000 was distributed by the famine relief committees under international control. The bulk of this money represented the balance left over from the administration of surtaxes imposed in connection with the maritime customs duties in 1921, and grants made by the American Advisory Board, entrusted with funds raised in the U.S.A., 1920-21.

The Committees which handled the relief herein described are voluntary organizations composed of Chinese and foreign members in equal members and are affiliated under a national organization known as the China International Famine Relief Commission.

ESSENTIAL DATA, 1921-1922

<i>Province</i>	<i>Famine year</i>	<i>Cause and Description</i>	<i>Amount distributed</i>
Anhwei	Spring, 1922	Flood, 1921 Poor crop, 1922	\$530,000
Chekiang	Spring, 1922	Flood	213,000
Kiangsu	Spring, 1922	Flood	430,000
Shantung	Spring, 1922	Flood	700,000
Honan	1921-22	Excess rain	767,000
Hunan	Spring and summer, 1922	Drought, 1921	750,000
Hupei	Spring, 1922	High water, 1921	351,000

Shansi	Continuance of drought famine of 1921 and wheat failure	122,800
Swatow	Winter, 1922, Typhoon	100,000
Szechwan	1922 Drought	147,000
Shensi	1922 Flood, hailstorm	125,000
Kansu		81,000

As to the manner in which the benefits were given, it suffices to quote the established policies of the famine relief commission as follows:

POLICIES

Wherever Possible I. Grain rather than cash to be given to the suffering population in famine regions—doing away with grain profiteering and keeping the prices down to a reasonable level to enable the poor people to secure their food at as low a price as possible.

II. Employment, rather than free grant, to be given and paid for in grain. Some constructive work or local improvement to be undertaken in connection with the labor-relief. Help given in return for labor done, corrects the demoralizing effect of dependence upon charity, and leaves a permanent improvement which may help in preventing future famines.

III. Grants of relief to be made in the form of loans to the local community benefitted, rather than to give help simply out of philanthropic motives. Those loans should be granted under easy terms of repayment and may be free of interest for the whole or part of the term of the loan.

This Commission, it well be remembered, is a federation of the international relief committees, most of which were actively functioning during the great drought famine of 1920-21 in the northern provinces. Its functions are

- (1) To handle relief measures in time of famines due to natural causes and,
- (2) To promote ways and means of preventing future famines.

**Famine
Prevention**

In the direction of famine prevention, which really is a line on which the Commission aims to specialize, the Commission's program is as follows.

- (1) Better controlled natural forces through
Afforestation of drainage areas of large streams,
Dredging or deepening of rivers and
Repairs to or building of important dykes-
Reclamation of inundated lands,-Preventing or
lessening the chances of recurrence of floods.
- (2) Increase of production and profit through
Improved agricultural methods,-adaption of
modern farming to Chinese rural conditions.
Improved method of marketing of farm products,
etc.
- (3) Broadening of margin of livelihood of the Chinese
farmers through-provision of rural credit
system-savings of farmers.
- (4) Better distribution of farming population through
colonization-development of hitherto uncultivated
lands.
- (5) Better system of inter-village communication
through building of highways, incident help in
marketing of products, and development of local
commerce.

Dyke building is especially notable in the work of the Committee in Hupeh Province while road construction has been a standing job of the committees in Hunan, Honan and Shantung.

River control is engaging the attention of the Committee in Kiangsu (Shanghai) and recently the Shensi Committee was contemplating a large irrigation program.

The Commission has also appointed a sub-committee to deal with problems of rural economy in China. This sub-committee plans to introduce the "Raiffeison" banks to Chinese villages. Judging from the success attained in Burma, India and Japan, these "banks" or societies should prove helpful to the Chinese farmers. A few "experimental societies" are already in operation in villages near Peking.

CHAPTER LXX

THE MORAL WELFARE LEAGUE OF SHANGHAI

Isaac Mason

The Moral Welfare League of Shanghai was formed in 1918 as the outcome of an earnest desire to promote improvement in vice conditions at this great centre. The Shanghai Missionary Association and the W. C. T. U. first moved in the matter, and on May 16th, 1918 representatives of seventeen religious and philanthropic societies met and organized a "Moral Welfare Committee," the name being later changed to the one heading this article. Other societies have joined, and there are now 26 local bodies represented, comprising British, American, Japanese and Chinese residents of the Settlement. Most of the societies, as well as many individuals, contribute yearly to meet the financial needs of the League.

Organization The Moral Welfare League functions through a General Committee composed of officially appointed representatives of the constituent societies. From this Committee is elected an Executive Committee, and the Officers. The League has no powers beyond those of any voluntary organization; its principal function thus far has been to provide an avenue for the expression of the moral opinion in the International Settlement on law and order, in relation to the social evil.

Elimination of Brothels By means of investigations and publicity, largely through the League's efforts, public feeling was sufficiently stirred to result in the appointment by the Municipal Council of a Vice-Commission in 1919, on which several members of the League sat. The Commission's Report was adopted by the Ratepayers' meeting in 1920. The first provision was "That brothels be eliminated," and as a means to this

end, existing houses were licenses at a nominal fee, and one-fifth were to be closed every year, so that in five years no licensed houses will remain. Four drawings have taken place, and only 98 licenses remain, and these lapse automatically in 1925.

**Street
Conditions
Improved**

There is fairly general agreement that public solicitation to prostitution, so far as Chinese are concerned, is much less prominent here than it was some years ago. While the population is rapidly increasing, it is significant that police charges for offenses of this nature are less than they were before the League was formed. There is no satisfactory evidence of any considerable increase of "sly" prostitution in the Settlement since the closing of licensed houses began. It is said that some displaced women carry on their profession in neighboring territory; so far as the French Concession is concerned, the official figures show a slight decrease instead of an increase; for Chinese-controlled territory we have no figures, but conditions are not noticeably worse than before. We have reason to believe that the closing down results in some giving up the business, which is a gain not only to our Settlement, but to society in general.

**A Remedial
Effort**

A monthly average of about 30 women and girls appear at the Mixed Court of Shanghai, charged with solicitation; it has been the custom to impose a small fine, or a short imprisonment. The fines have usually been paid by the brothel-keepers, or others interested, and the girls continue as usual. With the approval of the Court and the Police, we have opened a Home to which girls can be sent for two weeks or longer, instead of being fined. In the four months during which the Home has been open, 50 women and girls have been inmates, and they have greatly appreciated what has been done for them. While in detention the girls are dealt with sympathetically, and are encouraged to make a fresh start in respectable living. A Municipal law provides that no girl can be compelled to remain an inmate of a brothel. The problem of finding a way of living for those who wish to leave the life is a difficult one. But even the short time spent in the Home

is well worth while; the rest is beneficial to the girls, and they have a chance to catch visions of a happier life.

Publications Bulletins in English have been issued at intervals, a series of eleven having already appeared, and these, besides printed Reports, have been widely circulated. Four publications in Chinese have also been sent out.

CHAPTER LXXI

DOOR OF HOPE AND CHILDREN'S REFUGE

Ethel Abercrombie

Beginning Burdened by the fearful lot of the brothel girls in Shanghai, five missionary women opened the Door of Hope in 1901. The work steadily grew until in 1904 a separate department known as the Children's Home had to be made to take in singing girls and others in danger of becoming prostitutes. The Children's Refuge started — by a Committee of Shanghai community ladies — a year before the Door of Hope under the name of the Slave Refuge to save ill-treated slaves and famine refugees. In 1922 the Committee of the Children's Refuge approached the Committee of the Door of Hope to amalgamate the Children's work of the two organizations. This was accomplished in March 1922, the united work they being known as Door of Hope and Children's Refuge.

Administration The policies and development of the work are controlled by a Committee of ladies residing in Shanghai. For 1924 they are—*Chairman*, Mrs. E. Evans, *Treasurer*, Mrs. A. G. Parrott, *Secretary*, Mrs. H. Broomhall, Miss M. Jewell, Miss E. Spurling, Mrs. I. Woodbridge (Substitute). The direct management of both institutions of the Mission is in the hands of the resident foreign missionaries and Chinese assistants.

Location (1) Door of Hope, Industrial Home, First Year Home, Mary Fitch Memorial Sanitorium, Bonnel Memorial Chapel, on the Dong-chi Road beyond Tien-tung-an Railway Station, North Szechuen Road Extension.

(2) Receiving Home for the Door of Hope and the Children's Refuge at M. 396-9 Foochow Road. Easily found between Hupeh and Chekiang Roads.

(3) Children's Refuge, Industrial Department, near the Jessfield park, 33 Brenan Road.

(4) Children's Refuge, School, Kindergarten, Jewell Memorial Chapel and six cottages at the north end of the Kiang-wan village, ten minutes walk from the Kiang-wan railway station.

Work of the Homes (1) The Receiving Home gives temporary shelter to any women and girls in trouble and is the receiving center for the whole work. Evangelistic services and a day-school are also held here.

(2) The First Year Home gives the girls an elementary education for three hours daily, and training in sewing and household work. Chinese dolls are made and sold in this Home.

(3) The Industrial Home is for those girls who have satisfactorily passed through the First Year Home; embroidery and other hand-sewing is made for sale. The girls are paid for their work, becoming self-supporting and are taught to spend their money carefully. Most of the girls leave this Home to be married to Christians.

(4) The Mary Fitch Memorial Sanitorium has wards for tuberculosis, specific and medical cases, besides rooms for isolation.

(5) In the Children's Refuge, Industrial Department, knitting of every description is done here for sale. The girls are paid for their work and fitted to go into homes of their own.

(6) The Children's Refuge, Kiang-Wan department, primary schools and kindergarten have a curriculum correlated with ordinary mission schools and taught by efficient teachers, foreign and Chinese.

Entrance Requirements Women and children desiring admittance should go to the Receiving Home, where at any time day or night they will be given careful attention. Here each case is decided on its own merits after proper investigations and transferred either to the Door of Hope or Children's Refuge. No charge is made for admission but missionaries are expected to help bear the expenses incurred.

Finance The expenses of the Door of Hope for 1922 amounted to \$ 32,866.78 and the expenses of the Children's Refuge to \$ 32,630.45, making a total of \$ 65,319.23. Municipal grants were given the two Homes

of Tls. 4,000 and Tls. 3,000 respectively (\$ 9645.29); industrial work done in the homes provided \$ 17,336.16. But the larger part of the money needed, \$ 38,000, came in answer to prayer and faith in God's conditional promise "Seek ye first the kingdom of God and His righteousness and all these things shall be added unto you."

CHAPTER LXXII

THE PRESENT SITUATION OF THE ANTI-FOOT-BINDING MOVEMENT

Martha E. Pyle

The early years of the present century found Mrs. Archibald Little travelling throughout China in the interest of the natural foot. With the backing of the high officials she organized the T'ien Tsu Hui, the Natural Foot Society.

Upon the return of Mrs. Little to Europe in 1907, the Natural Foot Society was turned over to the Chinese with Mr. Shen Tung-ho as president.

No National Organization Probably the revolution that followed in 1911 and 1912 with consequent change of government frustrated the organization; for, so far as investigation is able to discover there is now no organized national movement. The movement is carried on in some places by the Tuchun, and at others by more or less individual impulse.

Shansi The Province of Shansi seems to lead in this matter as in many others. This is from a Y.W.C.A. worker in Fenchow:

“Your letter concerning anti-foot-binding in Shansi came a few days ago. It is almost past history here, and I do not know just what is referred to as the ‘prize system of Shansi.’ In 1918 and 1919 there was a vigorous movement and we are seeing the results now. We simply do not see bound feet at all, even in the villages, though I suppose there are some places in the mountains where bound feet still exist.”

Fenchow, Shansi Description of the movement of 1918 and 1919 in Fenchow, Shansi.

“Every month brings news of some new movement set on foot by the progressive governor of Shansi, Governor Yen. The past month has seen the

attempt thoroughly to enforce anti-foot-binding laws. Last year in Fenchow attempts were made to frighten people into unbinding feet by heavily fining all who were seen on the street with bound feet. For a while women were afraid to leave their courtyards, but vigilance soon ceased and conditions were helped but little. This spring, working through the magistrate of the city, all women and girls of government and church schools were asked to join the anti-foot-binding society and to take a part in inspecting feet of all women and girls in Fenchow.

“It was gratifying to see the businesslike method with which all details were worked out by the governmental officials. Each girl was provided with a badge stating her office and a certificate showing her right to engage in such a movement. Instructions were given as to how to proceed on entering a court, and leaflets were given to be read and explained to the women telling them how to proceed after unbinding. There is no patent corn plaster warranted to remove all sources of aches or the unshapeliness of a once bound foot, so instructions were of great help. A liberal amount of money for cart fare was sent with the assurance that more would be sent if this proved insufficient. But no pay was offered for the service of the inspectors.

“In inspecting a court the girls and chaperone entered leaving the policeman at the gate. The old men stood in the court while the girls entered each room taking the name, age, and address of any woman found still binding her feet. It was not necessary to see the bare foot to know its condition. By feeling of the instep a person could detect the stiff bandaging of a bound foot. The work was carried out most systematically, the teams, going out from five to seven o'clock each day until the task was done. It is interesting to know that the hardest territory was delegated to the church folk to inspect, which they regarded as a compliment to their honesty in not shirking an unpleasant task.

“When all the ground was covered a complete report had to be prepared and sent to the governor. This showed 1880 homes visited by our people and about 2590 women examined. Of this number few were found with bound feet. We are wondering how long it will take for the women to bind up their feet again after the fear of inspection is safely past. But Governor Yen also has thought of this and has set on foot a movement whereby all young men students are to be exhorted to declare themselves as being in favor of women having natural feet. Buttons are to be worn bearing the words, “Natural Foot Society” and, “I will not marry a woman having bound feet.”

TYPICAL LETTER

“I had shared the general impression that the custom had been stamped out in all parts of China, because one almost never sees a young woman or little girl with bound feet in our cities or towns; but I find that in the country places it is still crippling and marring the poor little girl, especially those of the poorer classes. In the churches it is never practised, unless the mother is a non-Christian. As far as I am able to find, there is no organized propaganda at present.”

A missionary who itinerates in villages around Shanghai and Sungkiang and conducts day schools at many points, states that at some villages practically all feminine feet are bound, at other villages practically none are bound, while at still others the proportion is about fifty—fifty.

It has been impossible to secure data from the remote interior, but from this rather inadequate study, it may safely be stated that at present, in cities where the force of the former propaganda of the Natural Foot Society was felt, the custom is obsolete. Where some official has continued the propaganda the same is true. In the country and places remote from Chinese modern movement the custom still obtains.

CHAPTER LXXIII

YANGTSEPOO AND OTHER COMMUNITY CENTERS

D. Y. Tsien

History The Yangtsepoo Social Center was founded in 1917 under the auspices of the Social Science Department of Shanghai College. The Nantao Christian Institute has just celebrated its ninth birthday. The Community Guild in Hunan was started five years ago. The new building for the Swatow Christian Institute was completed in 1920. Then the Baptist Mission started two centers in Ningpo and Hangechow respectively. Tsaokaitu Center in connection with St. John's University, Shin Ming Sui and Lo Chuin Sui in Soochow were started recently. At present there are nine distinct community centers in China besides the institutional churches which carry on work of a similar nature.

Organization All the above-mentioned centers are either partly connected with the missions or directly under their control.

Though no two centers carry on the same activities, nevertheless, the activities undertaken by the various centers are somewhat similar in nature and may be roughly classified under six headings; educational, medical, social, recreational, esthetic and religious.

Education The educational work of the different centers varies according to the needs and conditions existing in the community. Three centers have a well organized day school for boys and girls and charge high tuitions. Nantao has conducted a commercial school and a part time free school with marked success. Nearly all the centers have night schools in which are taught English, Chinese and arithmetic. There are more than three hundred students enrolled in the Yangtsepoo night school, most of whom are factory workers. Well conducted kindergartens are to be found in Ningpo, Nantao

and Swatow. Illustrated lectures on hygiene, civic matters, and popular education have been broadcasted from different centers many times a year. Reading rooms have been taxed to their seating capacities and library books borrowed and used extensively. The Yangtsepoo Library contains a complete collection of books on social work published by the Russell Sage Foundation, New York. A class in social work was conducted last year by Prof. D. H. Kulp II, in Shanghai and Hanchow and attended by one hundred and twenty five persons representing college students, preachers, missionaries, and social workers of the three centers in Shanghai. It is quite encouraging to learn that the tuitions received in many centers cover the expenses of the educational departments.

Medical Work Communities in China are in great need of leadership in matters of health. Social Centers cannot contribute much toward the actual healing of the sick but they are making great contributions along other lines. Perhaps their greatest contribution is being made by teaching both individual members and organizations in the community what their responsibilities are in health matters. The large manufacturing interests in the Yangtsepoo district have recognized their responsibilities by the establishment of the Industrial Hospital at the Yangtsepoo Social Center. This hospital and its daily out-patient department has been run successfully for four years. While administered by the Social Center, it is entirely supported by the factories and is exclusively for the use of their employees. Various features have been added to the Industrial Hospital such as a visiting nurse, lectures and exhibits on public health, first-aid classes for foremen in the various mills, baby welfare campaigns, etc.

Nantao, Tsaokaitu, Swatow and other centers also are working for improved health conditions in their respective communities by free clinics, health campaigns and the like.

Social Work Social work is one of the important features undertaken by the community centers. Men can no longer live a Robinson Crusoe kind of life. The

organized club work for men, women, and children in the community meets a distinct need. Hospital social work has been introduced by the Industrial Hospital in sending investigators to gather the social data in order to help the doctors make more correct diagnoses. The three centers in Shanghai were requested to help in the investigation of the industrial conditions of the sections where the centers are situated. Social meetings for the people in the community with good attendance have been often held. One of the best efforts ever made in attempting community organization was the inviting of the Street Unions in Shanghai to make the Yangtsepo Social Center their headquarters. Special women workers have been secured by some centers to go out to the homes of the people to obtain closer contacts and clearer information. The employment bureau in Yangtsepo recommended more than seventy persons to the factories as skilled and unskilled workers.

Recreation Recreation has been recognized as an effective remedy for social evils like gambling which is so common in Chinese communities. Billiard tables, ping pong games and chess rooms have been provided by many centers for the recreation of their community members. Playgrounds have been used for the children and adults to have group games and calisthenics. Lantern slides have been shown in all the centers with good attendance. Four centers have already purchased cinematographs to entertain the people with regular shows.

Esthetics One of the functions of the community centers is to select the best men or women in musical ability to form a club to give entertainment to the people in the community. Soochow and Ningpo have organized such clubs with great success.

Religion Religion is the soul of community centers and the inspiration of all the department activities. The nine centers are either the direct or indirect outgrowth of the Christian enterprise. Sunday schools are to be found in all centers, regular Sunday services are held, Bible classes conducted and personal work planned. Christian literature is placed in the public reading rooms.

Finance and Support The community center has been considered as "the house of the people"; it should naturally be supported and financed by the people in the community. The missions may invest, if they wish, in the land and buildings but the running expenses should always be met by the community. People will give when they understand that the thing is worth while. Some of the centers are independent financially and a few still receive small appropriations from the missions. The total receipts of the Yangtsepoo Center during the last year amounted to \$ 20,631.65 and that of Nantao \$18,850.00.

CHAPTER LXXIV

WORK FOR RICKSHA MEN

J. C. Clark

So far as we know the first organized work for ricksha men as a class was started in Shanghai in June 1913, by Mr. George Matheson.

The work from the first has been generously supported by the public and much appreciated by the ricksha men.

To quote from the 1923 report of the Shanghai Mission:

“The object of the Mission is to uplift and help the coolies generally, and to ameliorate, as far as possible, the condition of the sick and destitute among them.

Aims With the view to obtaining the desired results, at least in a measure, the work is organized on the lines of *Relief work*, combined with *Evangelistic Effort* and *Elementary Education*.

The past year has been one of great activity in all departments.

Attendance in the halls, where the accommodation is always strained to the utmost, includes nightly representatives from many provinces in addition to Shanghai and all its coolie section and outlying suburbs.

Testimony to the influence and far reaching effects of the Mission's teachings on the fluctuating masses dealt with has been received from far distant provinces, proving that Christianity and enlightenment often travel by circuitous paths.

Traffic Instruction *Instructions in Traffic and other Regulations* are given at all the large meetings. The majority of the men evince great eagerness to master the intricacies of the traffic difficulties and regulations.

The necessity for the observation of *honesty* and *civility* in all their dealings with the public and the maintenance of peace and order at all times, is strongly impressed upon the men, and although in so abnormally large a flock there must be some black sheep, and some less intelligent than others, a generous and gratifying acknowledgement of the value and good effect upon the men of such instructions has been received from the Shanghai Municipal Council.

According to the Municipal Council Report for 1922, and Budget for the year 1923, Taels 5,000.00 was given to the "Ricksha Mission" Building Fund by the Shanghai Municipal Council as a recognition of the splendid work carried on by the Mission.

It is estimated that as many as 500,000 different coolies pull rickshas in Shanghai in a twelve month period.

Religious Work Although *Church and Evangelistic Work* are not so prominently in the public view as Relief Work and other departments of the Mission's work, yet *in the Church* lies the nucleus of all the work.

During the past year there has been a steady maintenance of the *Gospel Work* in the halls, schools, and open air, which has been accompanied by considerable augmentation of membership and increase in organization and interest. A larger number than in any former year of men and women have been added to the Church.

Two Sunday Schools, representing an average attendance of 800 children, are held all the year round.

Schools *The two day schools* continue to be very popular institutions. During the past year, as in many preceding years, a number of boys, having completed our educational courses, have left to occupy respectable, and in some cases, very good positions obtained for them. Excellent accounts of our boys are received from their employers. After years of independence, many old boys are still loyal to the Mission, attend meetings and help in various ways. The average enrollment at the two schools, boys and girls, is 200.

Work Among Women is carried on all through the year.

Industrial Work *A Small Industrial Work* is carried on in which the poorer women are employed in making garments for free distribution among destitute coolies.

Statistics for the year:

Meals... ..	95,050
Special Christmas food parcels	12,000
Garments	2,750
Sandals	1,500
Number-meetings in halls... ..	696
Monthly attendance-halls (average)	12,500
Weekly attendance Sunday Schools (average)	800

Summary "The number of Gospel and Instruction meetings held during the year in halls, lodging houses, homes and open air, and the approximate number of persons reached thereby as based on record books, and the workers' diaries are:

Meetings	11,896
Persons reached	415,000 (approximately).

It is a very remarkable fact noted in the Mission's work that men who do not need to call on the Mission do not come up and take the free meal tickets offered at the close of each meeting although they could easily do so. Neither do they come to the Mission to sleep if they are not really in need of free shelter. Many times have men asleep on the floor voluntarily gotten up to share their blanket and place with a more needy man coming in late. The Mission's plan of trusting the men and putting them on their honor seems to have met with a finer response than is some times experienced when the so-called upper classes are put on their honor.

Several other cities beside Shanghai have made a start in giving some kind of help to ricksha men. The following is all the information we have been able to secure.

Other Cities *Peking*—Seven years ago a committee raised about \$2,000 and built nine enclosed shelters for ricksha coolies. They kept fire and tea in these

shelters. The government now helps and has built some twenty shelters. They provide relief for some of the most destitute of the coolies.

Foochow—Several efforts have been started but in some cases the government interfered and the coolies made sport of an effort to teach them to read saying, “the new learning would not help them to run faster and would be no use unless they changed their work.”

Hongkong—Something similar to the Shanghai plan is in prospect.

Canton—The Ricksha Mission in Canton was started in 1917 by a Chinese Christian named Cheung Tsoh Kei. It has now grown to considerable proportions and has a budget of \$1,000 per year. There are about 100 members in their church and a primary school with forty children of ricksha men.

CHAPTER LXXV

WORK AMONG THE CHINESE BLIND

George. B. Fryer

Scope It is impossible to quote the correct numbers of the blind in China, but in a recent article on Trachoma, Dr. Howard of the Rockefeller Foundation in Peking, came forward with the startling statement that there are at least 3,000,000 who are blind in both eyes: 6,000,000 who are blind in one eye, and 20,000,000 who have serious diseases of the eye, many of whom will eventually be blind or nearly so.

Causes of Blindness The chief cause is trachoma. In many parts of China over thirty-five percent of the population are victims of this disease: small pox, venereal diseases, dirt and accidents figure largely among the other factors. Over sixty percent of the blindness in China could have been prevented had simple remedies been administered.

Agencies at Work (1.) There are twenty-nine schools and industrial homes for the blind, in thirteen provinces, with about 1,200 pupils and workers, and their spheres of influence. (2.) Various mission hospitals and health committees are curing diseases of the eye and spreading abroad many preventive measures. (3.) Individual missionaries and others are teaching many blind to read and work, and become useful citizens in their homes. (4.) The special Committee on the Promotion of Work Among the Blind in China, organized by the National Christian Council, is trying to unify the work and assist in the urgent need of expansion.

Divisions of the Work *Educational.* The blind in the various schools are given as thorough an education, as their limited funds allow, which is more necessary to a blind man than to his seeing brother. The higher educated, the better equipped he is. Graduates are teachers, organists, masseurs, Bible-workers and evangelists. Two have graduated from St. John's University and at once

found useful and lucrative positions, one as a teacher of English and the other as a dictaphone typist.

Industrial The blind are taught to become as nearly self-supporting as possible. Knitting, weaving cloth and rugs, reed rattan and bamboo baskets and furniture, brush making and poultry raising, are the chief industries taught which have already proved to be successful.

Production of Braille Literature There is a great need for Braille Literature and Text Books. A start has been made in the printing of text books in UNION MANDARIN BRAILLE and other literature is expected to follow. Now that the Blind can be taught to read, reading matter must be provided for them. Nearly 450 portions of the Gospels and 257 copies of the Primers were sold during the year.

Promotion of Home Teaching Any one who can read ordinary Chinese can help the blind to read and write. Primers have been published with the written character over the Braille symbol to facilitate the teacher.

Preventive Work The hospitals are doing valuable services in curing those who come to them for help, and the Council on Health Education has provided literature dealing with the causes and prevention of blindness, also lantern slides and posters and has also worked out courses of lectures and charts for the use of any who may be able to use them. They have also organized publicity campaigns wherever possible.

Mandarin Braille Quarterly Letter This extremely useful Quarterly has been sent periodically to all blind persons who can read it. It is edited by the Rev. G. A. Clayton, and printed in Peking on a stereo-typing machine.

Central Depot for Sale of Industrial Work Plans are being formed for a Central Depot where industrial work made by the blind in China may be sold. Great difficulty is being experienced by many schools and industrial homes by not having an outlet for the sale of their work.

Normal School A normal school is much needed for the training of teachers of the blind.

PART X
LITERATURE
CHAPTER LXXVI

BIBLE DISTRIBUTION DURING THE YEAR

G. Carleton Lacy

Primary Task The distribution of Scriptures is a primary task of the Christian Church, for which the Bible Societies have been commissioned. That is by no means their only duty. Books have to be printed and bound before they can be sold. The type-setting and plate-casting and proof-reading process precedes that. These in turn must be anteceded by the work of translation and transcription. A review of articles in the CHINA MISSION YEAR BOOK during the past decade will indicate that the Bible Societies have given much time and money to this translation work. With the completion of the major enterprises committed to them by the missionary conferences,—the preparation of the Union Mandarin and Union Wenli Versions of the Bible,—no large translation work remains on the boards. The Bible Societies will be constantly at work bringing out new translations of portions for various dialects, revising colloquial texts, and preparing manuscripts and plates for various editions and scripts. This leaves the Societies free, however, to give their chief attention to the work of distributing Scriptures.

This is not so simple as it may appear. To put the books within the reach of everyone, to make them attractive, to prevent waste, to insure prompt delivery, to create demand, and match it with supply,—these are some of the simple elements in the problem. Complexities enter with the selection and supervision of field staff,

the dealing at long range with a scattered, unknown constituency, the constant change in language and literary taste, and the attempt of foreign agencies to supply a Chinese field with a Chinese product largely through foreign channels.

Distribution Three distinct methods of distribution have been employed by the Bible Societies in China. Combined, these have resulted during the past year in bringing the circulation figure to the unprecedented total of 7,564,494 volumes. This is rather amazing! It has taken place in a year notoriously tempestuous, with warfare and brigandage rampant everywhere, with missionary travels seriously interrupted, with colporteurs falling into the hands of bandits, with mail and freight routes brazenly robbed, and with a fearful property loss for the Bible Societies in the destruction of the Fukuin Printing Company in the Yokohama earthquake. In 1922, when the circulation figure fell somewhat below that of the previous year, Dr. Bondfield reviewed the situation from his vantage point of long experience, and questioned whether the maximum circulation for any one year may not have been reached. It was then under the seven million mark. The rapid increase in the output of other forms of literature placed within ready reach of the population in every part of the land, relieved the distributor of Scriptures of his former unique position as the sole bearer to remote villages of the printed page in popular form. The Bible, once the forerunner of vernacular literature, has helped to bring about the literary renaissance which gives to common folk everywhere a wide choice of newspapers, pamphlets, novels, essays and poems, written in the language of everyday speech, and sold at a popular price. The intrepid colporteur, pushing his way faithfully beyond mountain barriers and weary desert wastes, is now out-stripped by the mail carrier bringing the output of many port city presses way beyond the last borders of the country. Yet Scripture distribution goes on unabated.

Colporteur The time-honored, world-around method of distributing Scriptures is by the hand of the colporteur. He has been the pioneer evangelist.

Many a new field has been opened to the Gospel through his sacrifices. Far and wide he has traveled, humbly he has labored. He has been despised and rejected of men. Yet ever and from everywhere come the stories of men gloriously won to the fellowship and service of Christ through the testimony of The Book first brought by one of these humble ministers. During the earlier days of missionary work in China, almost the entire circulation of Scriptures was secured through these paid colporteurs, or through missionaries selling as they traveled. This method is still very largely used. The British & Foreign Bible Society alone employed last year between three and four hundred such workers.

Paid colporteurs are under the direct supervision of the Bible Societies, reporting in person to the nearest sub-agent, and having their work directed by him. Or, they are supported by a Bible Society, and work under the direction of some missionary in his field. Or, they are engaged and directed by a Chinese church, which may receive a grant from the Bible Society by way of subsidizing his work and salary. Each of these methods has its advantages, and is more adaptable than others to the type of work and field of labor to which it has been applied.

Voluntary Services

The reduction in funds which followed The War compelled a considerable reduction in the number of paid colporteurs. Resources were to a large extent in the form of book stock already in hand, or contracted for with the printers. This led to devising new methods of distribution. The voluntary services of Christian pastors and laymen were enrolled. Grants of Scriptures were made, to be sold by these volunteer workers at such time and in such manner as might prove feasible. The missionary agreed to report on sales, and to see that catalog prices were charged. Proceeds from sales were allowed to be retained to apply on travel or incidental expenses of distribution; or, where necessary, to serve as a slight remuneration to those carrying on the work.

This special arrangement, once a necessary makeshift, has grown in popularity and success. Nearly 90% of the

American Bible Society's publications, and a larger proportion of those from the National Bible Society of Scotland, were put into the field in this manner last year.

Bookstore The third method used is that of the bookstore or depot. Each of the Bible Societies has a number of subagencies centrally located for the distribution of books under the supervision of a foreign missionary in the service of the Bible Society. While the major work of these men is the forwarding of books to, and the promotion of sales in all sections of the surrounding territory, and the supervision of colporteurs working in that field, most of them conduct a depot from which are sold large numbers of Bibles and Testaments. Growing Christian communities have felt the need of a center from which could be secured readily all sorts of Christian literature. Many institutional churches have provided, as a feature of their equipment, such a bookstore. These have become distributing centers for the Bible. Where conducted on a business basis, the Bible Societies have granted to the bookstore management a small commission on sales to apply toward expenses. The plan has been extended in a few cases to commercial bookstores, with encouraging results. The bookstore sale of Scriptures, especially in cities and large Christian centers, promises to be a constantly growing business.

The large issue of whole Bibles to mission schools is a considerable feature in the total distribution of bound Scriptures. Compared with the circulation figure of all Scriptures for the year, the number of whole Bibles is not large. It is worthy of note that this increased last year to *over 57,000* volumes. Fukien Province has for years been unique in persistently using more whole Bibles than New Testaments.

Unoccupied Territories The year's work in Bible distribution has presented two distinct groups of problems. One has to do with the reaching of unoccupied territories. The reports of advances along the Tibetan borders, among the various Tribes peoples, over into Kokonor, out beyond the Great Wall, on to the vast plains of Mongolia, and even in numerous big "spots" within the

eighteen provinces, are full of romance. These regions are being entered by itinerant missionaries and paid colporteurs. Travel expenses are heavy. Populations are sparse. Languages are strange and various. Temptations are severe. Discouragements abound. Supervision is difficult. The Bible Societies must have the coöperation of missions and churches in securing the right type of men for this onerous yet humble calling; in equipping them for the enterprise, and in supervising and coaching them as they toil. The sales are bound to be few, the outlay of money considerable, and the visible returns in kingdom building very slow in appearing. This sort of distribution is a genuine challenge to consecration and faith.

Occupied Areas

The other set of problems relates to distribution in so-called occupied areas. It has to do with adjustments to keep pace with the growth of a Chinese church. The Bible Societies, especially since the National Christian Conference, have found that their job consisted not only in distributing the Scriptures, but in getting the Chinese church to distribute. The church is responding. The voluntary distribution already referred to is one indication of that response. The more general observance of an annual Bible Sunday is another. The greater confidence with which grants are made to the churches for the employment of their own colporteurs expresses the recognition of this advance. Contributions from local churches are on the increase. More and more orders for Scriptures are coming directly from Chinese to the Bible depots, instead of through the missionaries. This involves doing office business in two languages instead of one. It enlarges the circle of correspondence far beyond the reach of personal acquaintance or knowledge of conditions of work. It makes more bookkeeping, increases risks, dissipates supervision. Yet it is welcome. Within twelve months the work of distribution has passed from a missionary project to a church program. That this transition year has registered the greatest circulation of Scriptures in China of any year in history is due to the loyal coöperation between missionary agencies and church forces alike, through which the Bible Societies have so largely functioned.

The circulation figures for 1923 are as follows:—

<i>Statistics</i>	<i>Bibles</i>	<i>New Tests.</i>	<i>Portions</i>	<i>Totals 1923</i>	<i>Totals 1922</i>
Nat'l Bible Society of Scotland	2,158	8,146	1,867,933	1,878,237	1,212,216
American Bible So- ciety	22,056	34,386	2,468,575	2,525,017	1,987,326
British and Foreign Bible Society	33,549	52,781	3,074,910	3,161,240	3,190,435
Grand Totals ...	<u>57,763</u>	<u>85,313</u>	<u>7,411,418</u>	<u>7,564,494</u>	<u>6,389,977</u>

CHAPTER LXXVII

THE PRESENT SITUATION WITH REGARDS TO CHRISTIAN LITERATURE

Elijah S. Nieh

To begin with, it may be said, in a general way, that Christian literature is in the same situation as secular literature. Nearly all of the modern literary men devote more of their time to translating than to original composition. This hastens the process of bringing Chinese ideas into accord with western civilization.

Translation Christian literature, from the beginning, has been in the hands of foreign missionaries. It was, therefore, unavoidably mainly a matter of translation work. Chinese writers served only as writing machines. They had no chance for free self-expression. Occasionally one of them could write independently, but their writings were not esteemed by the Church.

New Literary Talent In recent times, Christian schools have emphasised more and more the importance of studying the Chinese classics, and the Church has sent many young people to be educated abroad. As a result literary talent is springing up in the younger generation. Thus writing done by Chinese is gradually coming into prominence. There is a prospect that this will take the place of the literary work done by missionaries. One thing should be noted here. Though many Chinese do write at present—many of them excellently—most of their writing is in the form of short articles. The reason for this is that Chinese literary training does not teach people how to produce bulky works. Writers are led to spend most of their time and energy on style rather than on the search for material; consequently, the cry of those who desire to write is that they lack a supply of refreshing ideas. To amend this lack it is necessary for the Church to-day to translate the best western books.

Although Chinese writers do not write voluminous books, they have found an effective and suitable means of literary expression in magazines and bulletins. There has never been so many Christian papers and periodicals published as at present. About one hundred and thirty different ones now circulate in the Chinese Church. Most of them are supported by foreign funds; but in the main they are edited by Chinese.

Periodicals Most of these periodicals are denominational in tone, and are read largely by members of their respective churches. Scarcely any non-church people subscribe to Christian papers. Christian literature as a whole is not widely read by people outside of the Church. This is largely due to the general anti-Christian prejudice of the people.

Students Chinese students to-day are busy with the study of philosophy and science, and have no time to make inquiry into religion. In the last one or two years, they have been more or less carried away by the doctrines of socialism, and claim that we have passed the stage of superstition and religion. They have therefore no interest in religious literature. Of course Christian literature does not treat religion exclusively. It also includes topics of general interest. Now in this article by, "Christian literature", I mean all literature published by Christian organizations. The general public thinks that any literature published by Christian societies is for purposes of propaganda and has therefore more or less of the color of religion in it. Many of the students will not for this reason look at it.

Advertising The lack of proper advertising also militates against Christian literature. Practically all the books produced by Christian societies are unknown to the Chinese public. These societies do not utilize secular newspapers for advertising purposes. It is true they are expensive. But the results are good! This last spring I learned an interesting fact with regard to the circulation of Christian literature. Some ten years ago, one of the Christian organizations translated and published the "History of Socialism" by Kerkup. But little more than five hundred copies of the book were sold in all that time.

About three years ago, the Commercial Press published the same book in Mandarin, and in one year sold more than twenty thousand copies! In the translator's preface of this Commercial Press edition it was said that this was the first translation of this work. This incident shows that Christian publishing societies should do more advertising.

Style of Christian Literature Recently a prominent Chinese Christian writer remarked, that Christianity in China has only writings (文字) but no literature (文學). This is another, and the most important, reason for the fact that non-Christians do not read Christian literature. Christian books will not be appreciated by Chinese readers until they have, as Buddhist books did, won a place in Chinese classical literature. There is general criticism that the style of Christian literature is not up to the standard. In early years, the Church, in order to have literature which could be understood by the common people, adopted the Mandarin, which was then regarded by the old literati as the lowest style of writing. But now Mandarin is in the first rank of literature. It seems strange, therefore, to some of us that Christian writings are still being criticised. The only reason is that Christian writings, though in Mandarin, differ from that used in secular writings.

Mandarin The term "Mandarin" is now rather out of fashion. The popular style of writing to-day is called "Kuo Yü Wen" (國語文). People are easily misled by this name to think that Kuo Yü Wen resembles the common vernacular. But if a close examination is made of these popular writings we can instantly detect that the term does not express this idea. Kuo Yü Wen is really something between the common vernacular and easy wenli.

There is another variety of this Kuo Yü Wen. It was started by some of those doing translation work. Instead of translating the original into real Chinese they followed almost exactly the order of the foreign language. Some Christian writers have advocated this style. Fortunately the Church as a whole has not adopted their suggestion. This style has been a snag to the reading public, for it is somewhat unintelligible for those who know no English.

Needs It is the general cry of the younger Church leaders that existing Christian literature cannot meet the needs of China to-day. In former days, Christian literature played a large part in instigating the revolution to overthrow the old civilization by importing western ideas, inventions and discoveries. Therefore it was esteemed very highly by most of the educated class. But in recent years, people outside of the Church can write just as well as those in the Church, perhaps better. Therefore the Church devotes almost all of its time to producing literature on religion and ethics. The place which was formerly occupied by Christian literature has been taken from Christian societies by secular producers. Christian literature agencies are more than glad to see young China take over this burden of importing western civilization. But the Church, which seems to be doing a good thing by giving up the work of producing books on politics, economy, philosophy, and science, has lost her charm as far as literature is concerned for the best young men of the Republic of China. These men are devout admirers of the so called "New Civilization." The Church was formerly considered the leader in new thought and new life moulds, but now, it is said, she is not even keeping up with the New Civilization Movement.

This criticism, which is made by the new type of leader, is more a matter of agitation than of fact. It is the result of the Church not making any special effort to meet the needs of the intellectual classes as she did in former days. The Church has a greater task than just meeting the needs of the learned group in the nation. The Church has now fixed her attention on the masses, and left the selected few to the Chinese to tackle themselves.

Phonetics At this juncture, a word may be said on the phonetic movement. There are divided opinions in regard to this movement. Some think that the phonetic will be the means of unifying the different dialects and of simplifying writing. The Kuo Yü Magazine devoted one of its numbers to discussing this topic. Others think it is not practical to use the phonetic in place of the character. During this last summer, the writer met a specialist in phonetics, and asked him to translate one of

the articles which was written in phonetic in the Kuo Yü Magazine. It took him more time to do this than if it had been in characters; in some places he had to guess the meaning. The Chinese public is not so enthusiastic as the Church in the matter of promoting this system. The Sunday School Union may be said to be the most energetic promoter of this movement. The New Testament and many other popular Christian books have been translated into the phonetic. A phonetic paper was published for those who cannot read the characters. The phonetic helps to solve, to some extent, the problem of illiteracy, but it does not help to increase the percentage of readers in the whole nation.

CHAPTER LXXVIII

THE CHINA CHRISTIAN LITERATURE COUNCIL

H. J. Molony

Origin The C. C. L. C. was first appointed by the China Continuation Committee in 1918. It grew out of the Special Committee on Christian Literature of that body, the British and American Conferences of Missionary Societies having, in response to Dr. Ritson's proposal, decided to organize an International Christian Literature Council, and urging that similar bodies should be appointed in each of the great mission areas.

Early Work The Rev. G. A. Clayton brought out his "Index of the Chinese Literature of the Protestant Churches" in 1918, and the Christian Literature Council produced an important Report on "the Present State and Future Task of Christian Literature in China" for presentation to the National Christian Conference in 1922, but all through these years the Council has been restricted in its activities for want of funds. It had been hoped that the Missionary Societies at home would set apart a fixed proportion of their income for literature work, but this help was not at once forthcoming.

In the year 1920-21 a sum of G. \$1000 came to hand from the Federation of Women's Board in America and was handed to the Committee on Phonetic Script.

Timothy Richard Prizes The Council has administered the Timothy Richard Bequest, a sum of money left by Dr. Timothy Richard for the encouragement of Chinese Christian writers by the gift of prizes. The Council decided that it would be most in accord with the wishes of the donor if the annual prize took the form of a scholarship enabling the winner to continue his studies at a university. The bequest produces about \$245 Mexican a year. Scholarships were awarded in 1921 and 1922 to two students both of whom studied in Peking

Christian University. One of these decided to take up a course in theological training to prepare himself for work in Christian literature.

Work in 1923 Towards the end of 1922 grants began to arrive from abroad, G. \$900 from the Committee of Reference and Council in New York, and £215, and later £60, from the Conference of Missionary Societies in London. A forward policy was at once started, with the two objects of, (1) discovering and fostering the literary talent to be found in the general Christian Community, and (2) taking up some of the actual literary tasks not being attempted by existing Literature Societies.

With a view to finding and encouraging hidden literary talent the Council offered prizes to be competed for in Christian magazines. The following magazines participated in the competitions:—(1) The Y.W.C.A. Magazine, (2) The Nü Tao Pao, (3) The Young People's Friend (4) The Chinese Christian Advocate, (5) Progress, (6) The Lutheran Magazine. Three competitions a year were proposed with 1st, 2nd and 3rd prizes ranging from \$25 to \$5. A total sum of \$435 was paid out under this head.

Books in Preparation Under the heading of definite literary tasks the following are in hand:—a book of original Chinese Hymns, a book of Christian Poems, a book of Daily Devotional Readings and a book on Christian Evidences. In each case a Chinese Christian editor has been selected and is now at work, funds having been set aside for such expenses as are likely to be incurred shortly on these works.

Grants to Magazines Grants are also being made to magazines for the production of articles, and the Industrial Commission of the N. C. C. was helped with a grant of \$300 to enable it to publish two important articles on the subject of Western Industrial Conditions in China.

Status of Council At the first annual meeting of the National Christian Council considerable question arose as the connection of the Literature Council with the National Council. On the one hand it was difficult to bind the Literature Council with its broad objects, and obtaining its funds from such diverse sources, to a policy

of only publishing what was within "the zone of common agreement"—and who was to decide what that might mean?—and on the other hand the National Christian Council would not care to be responsible for reviewing the literature produced. At the meeting of the National Christian Council in the spring of 1924, the responsibility for the Literature Council was turned over to the N. C. C., which decided to appoint a sub-committee on literature.

Retreats Meanwhile the Council has endeavored to further its undoubted duty of fostering literary talent by gathering in retreat some of the leading Chinese Christian writers. The first retreat was held at Shanghai in September, 1923, when 11 Christian Chinese authors met with Dr. Rawlinson, Dr. Hodgkin, Dr. Leighton Stuart and Miss R. Brooks. The report of this gathering was most practical and stimulating, and it was evident that we may expect to see the vigorous prosecution of the Christian message by a group of Chinese writers. The Council asked the same group to meet again in retreat, with more Chinese members and the addition of Dr. Willard Lyon. This second retreat duly met on December 28, 29 and 30th, 1923. Sixteen people were present, of whom most were Chinese writers. The retreat unanimously reached the conviction that a Chinese literary organization is needed. A list of objects and activities for the new organization was adopted and a provisional organization Committee appointed. It is evident that the Council's policy of encouraging literary activity among the Chinese is to produce important results.

CHAPTER LXXIX

THE CHRISTIAN LITERATURE SOCIETY

D. MacGillvray

Origin The Christian Literature Society was born in 1887. Rev. Alexander Williamson, a broadminded, far-seeing Scotchman, had for many years circulated the Scriptures in China as Agent of the Scotch Bible Society, and out of this atmosphere was born the idea of establishing a Society which would expound not only the truth found in the Bible, but all truth as revealed without its covers. Such a mighty task was impossible for any one, even a giant, single-handed. Accordingly, he sought the coöperation of other missionaries, Dr. Young J. Allen of the Southern Methodist Church, Rev. Ernst Faber of the Lutheran Church, and other writers. But such missionary coöperation alone would have been insufficient; he required to obtain the sinews of war, and he accordingly sought the coöperation of like-minded merchants in Shanghai, and elsewhere, sharing with them the direction of his infant society. Some of these were attracted by the purely Gospel books, while others were drawn to educational features of his programme. Then came Dr. Timothy Richard, a man fit to be his peer in scholarship, blessed with vision and daring adventure. He took from the hand of his predecessor the wonderful weapon of Christian literature in the new society, and still further expanded the principle of coöperation by persuading various home boards to join in the good work, on both sides of the Atlantic. He was the first to induce boards to lend men and women for nation-wide work, a practise which has now become so widespread. We used to indicate the denomination of each one of the staff on our list of directors and letter-heads. We do so no longer—a small change, but very significant!

Chinese
Workers

But more, the society is unique in the possession of a large body of Chinese workers. At the beginning it was impossible to obtain a sufficient number of Christian writers, and accordingly the Society employed men who were, though not Christians, yet sympathetic with our point of view to provide the literary dress for the Christian ideas. We have worked along, however, to a point, side by side with the growth of the Chinese Church itself, at which we have a staff which is solidly Christian. There was coöperation from the beginning, but now we have reached the point where a unity, a fusion which is more than coöperation, which might only mean proximity, exists. By united staff meetings, united prayer meetings, and the like, the esprit de corps of the whole staff has been visibly bettered. Of necessity, at the beginning the word "writer" meant a more or less mechanical employee. Happily, that day has passed, and we have Chinese who are colleagues, able to make a solid contribution to the finished product. But better still, there are some who are themselves able to do original work, for long so justly desiderated. But now at length they are assuming larger proportions, to the great joy of the whole missionary body. When men and women of different denominations and from different parts of the mission field can combine in one society to preach by means of the printed page, surely the day of a united Church is not far distant.

CHAPTER LXXX

THE RELIGIOUS TRACT SOCIETY FOR CHINA

George A. Clayton

Origin The Central China Religious Tract Society was founded in 1876, and in 1915 united with the North China Tract Society, which had been founded in 1883, to form the Religious Tract Society of North and Central China, Incorporated. The Chinese Religious Tract Society was founded in 1878, and in 1895 united with the East China Tract Society, which had been founded in 1885, to form the Chinese Tract Society. In 1920 the Religious Tract Society of North and Central China united with the Chinese Tract Society, which was to have been called the "Religious Tract Society of North, Central and East China". But on applying for incorporation, it was found that the title was not acceptable to the authorities and it had to be altered to "The Religious Tract Society for China". This Society has its head depot and printing works in Hankow and a depot in Shanghai. The former Manchuria Tract Society has ceased to function. The united Society has a Board of Directors meeting in Central China (Hankow), with Committee in North China (Peking), East China (Shanghai) and Manchuria (Moukden). The minutes of Board are sent to the members of these committees, and these members can ask for the re-consideration of any action of the Board.

Coöperation with Other Societies The Religious Tract Society for China works in coöperation with the West China Religious Tract Society at Chung-king, and all manuscripts accepted by either Society are available for the use of the other. There are also Tract Societies in North and South Fukien doing special dialect work, and a Tibetan Tract Society has been formed which aims at reaching the people of that lama-oppressed land.

Distribution During its statistical year, 1922-1923, the Religious Tract Society for China sent out 2,966,376 publications of the value of \$41,413.06. The number of publications thus sent out was less by 167,917 than the number sent out in the 1921-1922 year, a decrease which is easily explained by the state of the country during the latter months of 1923. Sixty-five new titles were added to the catalogue, and a list of these will be found in the chapter of this book which deals with the new publications of the Protestant Churches.

Property The Society owns, free of all debt, two large buildings in Hankow. The Depot building provides on its three stories for the Depot, the offices and the residence. The Press is housed in another large three-storied building and, besides facilitating the work of the Society, brings in a substantial income. The Society now absorbs three-fifths of the possible output from the Press, and the question whether to further enlarge the capacity of the Press so as to meet the needs of the Missions in Central China or to limit the Press to its present capacity and discontinue mission and business printing as the work of the Society increases is having the careful attention of the Directors. At present there is no sign that any commercial press doing book work in Chinese, will be established in Hankow.

CHAPTER LXXXI

CHINA AS INTERPRETED TO THE OCCIDENT BY THE RECENT BOOKS

Kenneth Latourette

Changed
Interest

In articles in many periodicals there has been a marked change in the past twelve or eighteen months. In much of 1922 journalists were primarily concerned with the Washington Conference and in the United States at least there was fairly general congratulation on the outcome of the gathering and a feeling that China was at last being given a fair chance to work out her salvation. There was, to be sure, in some quarters an appreciation of the fact that China was still under constraint from the powers and that given internal conditions as they were no early achievement of an orderly, united government could be hoped for. These qualifications did not make any profound impression, however, and with the news of the increase of banditry, the Lincheng incident, the flight of Li Yuan Hung from Peking, and the financial condition of the government, there came in some quarters what was akin to disillusionment. Instead of the Washington Conference and its constructive actions newspapers and magazines have spoken most of robberies, anarchy and revolution, and China has for the moment fallen badly in popular esteem.

Fortunately the books on China which discuss recent events and which describe the country for the general reader suffer but little from the current pessimism and some times not at all. Dr. Henry Hodgkin has laid us all further in his debt by his *China in the Family of Nations* (London, Allen and Unwin, 1923). The volume is on the whole the fairest and most judicial survey of China's recent international relations that has appeared in book form and it has as well thoughtful chapters on the industrialization of China, the New Thought

Movement, and the contribution that the Chinese can make to the world. Professor E. T. Williams, who has spent many years in China, first as a missionary and then as a representative of the United States government has in *China Yesterday and Today* (New York, Thomas Y. Crowell Co., 1923) given to the American reading public a general book on the country. The chapters are of decidedly uneven merit. Those from three to ten inclusive contain part of the fruit of the author's own wide and discerning observation and are of real worth. Those on religion are not nearly so good and the sketch of the history of the past century is commonplace and lacks proportion. It is all distinctly readable, however. H. K. Norton, in *The Far Eastern Republic of Siberia* (London, Allen and Unwin, 1923) gives an American's view of a northern neighbor of China and is on the whole friendly to the republic and critical of the Japanese. There ought also to be mentioned as a general interpreter of China to the Occident *The China Journal of Arts and Sciences*. It is, as all the missionary body probably knows, prepared for a more popular clientele than was the late *New China Review*, a publication which came to an untimely end with the death of its lamented editor.

Travel

Books of travel have been rather numerous.

There is *The Temples of the Western Hills, Visited from Peking* by G. E. Hubbard (Tientsin). H. A. Franck has added to his books of ramblings in various parts of the world a well illustrated narrative called *Wandering in Northern China* (Century Co., 1923) in which he tells of his journeys in Mongolia and some of the northern provinces. Eric Teichman narrates experiences of 1918 in *Travels of a Consular Office in Eastern Tibet* (Cambridge University Press, 1922). Arthur de Carle Sowerby tells of interesting expeditions the first one in 1913 in *The Naturalist in Manchuria*, vol. 1, *Travel and Exploration* (Tientsin Press, 1923). The book has many illustrations and its chapter on the races the author encountered is of especial interest. In somewhat lighter vein is Elizabeth C. Enders', *Swinging Lanterns* (New York, 1923). Books of description of more limited areas include G. Bouillard, *Le Temple du Ciel* (Albert Nachbaur, Peking, 1923) and a volume made up largely of translations from the Chinese

concerning a garden in Soochow, Kate Kerby, *An Old Chinese Garden* (Chung Hua Book Co., Shanghai, 1923).

Fiction Was it Lamb who in his story of the origin of roast pig started the Western writing of fiction on China? It may well have been so, for most of his successors have presented China in a rather bizarre manner. There have been recently added to the list *Silk*, by Samuel Merwin (Boston, 1923) a tale of the intrigues of the Roman Empire to acquire the secret of silk culture, and *Kai Lung's Golden Hours* by Ernest Bramah (New York, 1923), a companion volume to the entertaining *Walet of Kai Lung* of earlier date.

Americans have in the past decade or more been cultivating a gastronomic interest in China. It is a very backward city in the United States which cannot boast at least one brilliantly lighted "restaurant" run by Cantonese in which a few semi-Chinese lanterns and bills of fare displaying chop suey, the various varieties of chow mien and in some instances genuinely Chinese dishes attract those who are looking for new sensations. It is not strange, then, that the year has produced *Chinese Recipes: Letters from Alice Moore to Ethel Moore Cook* (New York, 1923). The remark ought also to be made here, although its connection with restaurants may seem remote, that with the introduction of Mah Jong a large literature has begun to appear to offer guidance to an eager public.

Interpretations If the average American thinks of China as a land of laundrymen and restaurant keepers who find their recreation in gambling at Mah Jong, there are fortunately not wanting in the year's output, books which will, if he will but take the trouble to read them, give him scholarly and sympathetic interpretations of other phases of China's life. All Occidental students of China will mark as noteworthy the year that has witnessed the appearance of Dr. E. B. Bruce's two volumes on the Sung philosophers, *The Philosophy of Human Nature: Chu Hsi* (a translation of portions of his works) and what is meant to be an introduction to the former, *Chu Hsi and His Masters* (Probstain and Co., London). These are books which every missionary will wish to know and it is a matter for pride to all of us that out of our body there are still coming

men who are worthy of the title of sinologue. There are those who will find fault with Dr. Bruce's work, partly in some of the English words he has used for Chinese terms—for it is impossible to put Chinese philosophical terminology into a European language without long introductory explanatory notes of the connotation to the Chinese of the words they used and this the author has not always done in a satisfactory manner. A perusal of even the first few pages of *Chu Hsi and His Masters* discloses, too, some serious mistakes in proof reading which ought not to have been allowed to creep in. We should all be glad, however, that there has at last appeared in English a fairly adequate account of Sung philosophy. Quite as important as Dr. Bruce's two volumes is a book by Professor Alfred Forké, the eminent German scholar who was for a time at the University of California. This, to give it its full title, is *Mé Ti, des Sozialthikers und seiner Schüler philosophische Werke zum ersten Male vollständig übersetzt, mit ausführlicher Einleitung, erläuternden und textkritischen Erklärungen versehen.* (Berlin, 1922) At last, then, we have an adequate work, done with all the thoroughness of German scholarship, on the philosopher who is being so much talked of in these latter days. Other books on the religion and philosophy of the Chinese are a popular manual in French, Marcel Granet, *La Religion des Chinois* (Paris, 1922), a history of Chinese philosophy, *Storia della Filosofia Cinese Antica*, by G. Tucci, an Italian sinologue, a general manual on Eastern philosophy, M. R. Grousset, *Histoire de la philosophie orientale, Inde, Chine, Japon.* (Paris, 1923), and a new book on the Tao Teh Ching, *Lao Tzu, Le Livre de la Voie et de la Vertu*, by P. Salet (Paris, 1923).

Art

Chinese art is attracting much attention in Europe and America and the demand is bringing forth many books on the subject. Since those most interested are often wealthy collectors, the volumes are frequently in sumptuous form and are sold at a price prohibitive to most missionaries. Arthur Waley of the British Museum has prepared *An Index of Chinese Artists* (London, 1922) and a beautifully printed and illustrated *Introduction to the Study of Chinese Painting* (London, 1923). There has recently appeared, too, Agnes E. Meyer, *Chinese*

Painting as Reflected in the Thought and Art of Li Lung-mien, 1070-1106 (New York, 1923). There was also published in 1923 the third edition of Binyon's well known work, *Painting in the Far East*. There is a book, *Early Chinese Jades* by Dame Una Pope Hennessy (New York, 1923) which reflects price the of its subject and there are two on ceramics, *The Art of the Chinese Potter* (New York, 1923), and the elaborately illustrated *Wares of the Ming Dynasty* by R. L. Hobson (London, 1923). Even if most of us can expect to see these books only through the generosity of public libraries we can at least be glad that there are those in the Occident who have the means and are sufficiently interested to make them possible.

Language and Literature

Each year sees new books on the language and literature of China. Those that have appeared recently are J. B. Grant, *Exercises in Translation* (London, 1923), a book for beginners; *Poèmes Chinois de la Dynastie Song*, translated by G. Soulié de Morant (1923); Tsen Tsonming, *Essai Historique sur la Poésie Chinoise* (Paris, 1923); B. Kalgren, *Sound and Symbol in Chinese* (London, 1923); Ki Yun, *Le Lama Rouge et autres contes*, translated by S. E. Tchen-Loh and Mme. L. Paul-Margueritte (Paris, 1923); E. T. C. Werner, *Chinese Ditties* (Tientsin); and translations of some Chinese lyric poems by Hans Bethge under the title *Pfersichblüten aus China* (Berlin, 1922). The last named volume is illustrated with some Occidental pictures of a most advanced futuristic type.

Research

In addition to the volumes so far named there are a number which the more serious student of China will note with interest and which he will wish to examine and, if they suit his special interest, to study with some care. Professor Cordier is crowning his long life of arduous labor in things Chinese by a supplement and index to his well known *Bibliotheca Sinica*. The second fascicule of the supplement has appeared during the past year and we impatiently await the others. Professor Giles has brought out a new edition of his *Travels of Fa-Hsien (A.D. 99-414) or Record of the Buddhistic Kingdoms* (Cambridge, 1923). The older edition is probably to be preferred to this new one, for the latter does not contain the notes that added to the value of the earlier

one. In honor of the veteran Professor F. Hirth whose books all careful students of China have long used with pleasure and profit there has been published by Probsthain and Company (London, 1923) the *Hirth Anniversary Volume. A Collection of Twenty Eight Contributions towards Chinese and Central Asian Art and Civilization*. The volume is worthy of the scholar in whose honor it was published. An attempt on a somewhat new line is J. Rodes, *Les Chinois! Essai de Psychologie Ethnographique* (Paris, 1923), an analysis, as the title indicates, of race psychology. There is also E. Schmitt, *Die Grundlagen der Chinesischen Kultur*. There is a study of the Chinese stage which is chiefly of value for its illustrations, *The Chinese Theatre* by Chu-chia Chien, translated from the French by J. A. Graham (London, 1922). Henri Cordier has brought out a fourth volume of his *Melanges d'Histoires et de Geographie Orientales* (Paris, 1922), the present one being made up of five articles which have previously appeared in various journals between 1883 and 1918. There is a new study of the T'ai P'ing Rebellion by Dr. Wilhelm Oehler under the title *Die Taiping-Bewegung. Geschichte eines chinesisch-christlichen Gottesreichs* (Gütersloh, 1923) which attempts a more favorable picture of that movement than has sometimes been given. It is unfortunate that he could not have seen the still unpublished work by Professor W. J. Hail on that subject, for nothing so good has yet appeared. Works in European languages by Chinese have not been as plentiful as in some other years. One must note with gratitude the continuation of the excellent *Chinese Social and Political Science Review* with its articles, its collections of documents, and its special supplements, such as the study by Professor T. T. Lew of the treatment of China in the textbooks in use in American schools. There must also be noted the *Bulletins on Chinese Education, 1923*, gotten out by the Chinese National Association for the Advancement of Education and now to be had in a single volume at the Commercial Press. It is another of the books that all missionaries should know.

Missions Of works on missions the year has not seen as many as have some former twelfth-months. Probably the most notable book on Protestant work, and indeed, about the only one, is Dr. James

B. Webster's *Christian Education and the National Consciousness in China*. This is an interesting and valuable analysis of the educational background of China both old and new and of that of the West, with problems arising from the contacts between the two and the special contributions which Christian missions can make. It is a book which should be read in connection with the report of the educational commission. The two taken together make an excellent and thought-provoking introduction to the entire subject. Catholic missions are represented by a most attractive and rather bulky volume of letters from the members of the newly established American mission in South China, *Maryknoll Mission Letters. China* Vol. 1 (New York, 1923). These not only give an intimate picture of Catholic work but are one more indication of the increasing place which American Catholics are coming to have in the efforts of their church in China. There is, too, a volume on the Paris society that has labored continuously in the Far East since its foundation in the seventeenth century, *La Société des Missions — Etrangerès*, (Paris, 1923).

In spite of the fact, then, that China has not been brought prominently before the world in the special ways that it has during several of the past twelve or fifteen years, the output of books shows a growing interest in the country and, on the whole, the disposition to study the land and its people in a scholarly and sympathetic fashion. If missionaries no longer, as formerly, take a predominant place in the production of these books, they still have an honorable part and can be thankful that the interest they helped to kindle has spread outside their circles and is beginning to reach the West as a whole.

CHAPTER LXXXII

SOME CHINESE BOOKS RECENTLY PUBLISHED

T. C. Chao

**New Thought
Movement** No one can write on the books written by Chinese scholars and students without realizing that a tremendous output has been effected during the past two or three years. One thing the New Thought Movement certainly did is increase the literary activities of Chinese thinkers and writers. We have no space to note the numerous magazines and societies of learning that have come into being recently. But in passing we may mention "The New Man Society, (新人社), The Coöperative Learning Club (共學社), The Philosophy Club (哲學社), The Young China Association (新少年中國社), The Science Society (科學社), The Modern Man Society (今人會), The Sociology Club (社會學會), The Society for the Study of Modern Literature (文學研究社), The Society for the Study of Chinese Culture (國學研究會), and a large number of others. We may also mention such periodicals and magazines as The Psychological Review (心理學報), The Critical Review (學衡), Science (科學), The Literary Weekly, (文學週刊), The Effort Weekly (努力週刊), The Solitary Army (孤軍), The Pacific Ocean (太平洋), The New Education (新教育), The Sociological Review (社會學報), The Young China Journal (少年中國) and other popular and technical publications. Local papers are so numerous that it is impossible to even list them here.

**Desire to
Write** To the casual observer even it is evident that all the students who know how to use the pen are anxious to express themselves. Their motives are many. There is the desire to tell others what one has learned, to translate and to introduce new thought. Then there is an enthusiastic desire to tell and

compare experiences, and to secure social emancipation through the finding of something "common to all" in these joyful or painful experiences. The rebellious spirit as well as the thirst for the new find vent in literature. Individualism on the one hand demands an explanation of all things that have hitherto been accepted without being summoned before the bar of human reason. And on the other hand, the naked individual needs assurance in the sympathy of similar individuals. There has been no time like this in the history of Chinese literature. We find much indiscreet self-revelation and love, and much undefined and unrefined altruism and selfish benevolence. Again there is a rush for science. While it is true that many students neglect their studies and show a sort of docility combined with limitless and childish foolishness, there are many young men and women in our government schools that devote themselves to serious study, to science, philosophy and art. The love of science, meagre as it is, has become a strong motive for the learning and writing of many people in China to-day. In addition to all this, professors in the various colleges are turning their lectures into books. Such men as Kiang Kang Whu (江亢虎), Liang Chi Chao (梁啟超), Hu Su (胡適) and others all have their addresses printed. Finally we find patriotism in the growing national consciousness of Chinese thinkers that reveals itself in research work in Chinese history, philosophy, and present problems. Systematic efforts are being put forth for the discovery of China's true past.

Articles Consequently those who cannot write books contribute articles to papers and newspapers. And those who are able to write, both translate and create books for the small thirsty reading public. Just to give the reader some idea of some of the books that these authors have written during the last year or so, I shall take the books that I have in my study and give them a short review. I shall not mention other books recently translated and published on such subjects as philosophy, psychology, sociology, politics, literature, art, socialism and education. There is now literally an army of translators and reviewers many of whom have thus found a new profession and a new way of making a living.

Trends in
Thought

Of course the personal library of a Chinese student like myself is by no means representative of all the literary attempts made by the Chinese people during recent years. But it will probably suggest the trend of the times to foreign readers. Chinese who read anything at all read Mr. Liang Chi Chao's "Lectures" in three volumes (梁任公演講集三輯). These volumes contain chapters on such subjects as "My Reflections and Observations During My Travels in Europe"; "Europe after the Great War"; "The Awakening of China"; "In Europe"; "In London"; "A Bird's Eye View of the Peace Conference at Paris"; "Alsace-Lorraine"; "The League of Nations"; "The International Labour Problem"; "The Beginnings of Buddhism in China"; "China's Returned Students 5,000 Years Ago"; "Literary Translations and Buddhistic Classics"; "Buddhism and Tibet"; "The Translation of Buddhistic Books"; "Six Long Essays on Buddhism"; "The Philosophy of Lao Tzu"; "The Study of the Chinese People As a Race As Reflected in Chinese History"; "Chinese Language and Chinese Philology"; "Education by Free Lectures"; "The Progress of China During the Last Fifty Years"; "The Meaning and Value of Political Movements"; and many others. All these lectures are written in simple Kuo Yü which is at once literary and easy to understand. The reading of these three volumes is in itself an education. Then there are by the same author such books as "The Philosophy of Mo Tsz (墨子哲學)", "A Commentary on Mo Tsz" (墨子校釋), "The Method of Studying Chinese History" (中國歷史研究法), "The Political Theories of Tsin and Before" (先秦政治思想史), "An Introduction to the History of Learning in the Ching Dynasty" (清代學術概論), and "The Poet, Tao Yuan Ming" (陶淵明). In addition to these books Liang has two other volumes of "Lectures On Learning" (梁任公演講集兩輯). I have learned that Liang has also written the first volume on "The History of Chinese Buddhism" (中國佛教史); but I have not as yet seen the book.

Books on
Civilization

Liang Siu Ming (梁漱溟), a young man of about thirty and a professor of Hindu philosophy in the National University of

Peking has written two well known books which have had very wide circulation. The first one is called "The Civilizations of the East and the West and Their Philosophies" (東西文化及其哲學), in which he compares the characteristics of the two civilizations and criticizes both in a very audacious manner. The other book is called "An Introduction to the Philosophy of India" (印度哲學概論); this gives an account of the history of the systems of thought in India and their relation to Buddhist controversy between naturalists and idealists.

During 1923 there was a controversy waged among the intellectual leaders of Young-China—philosophers, psychologists, historians, geologists, and other naturalists, literary men and students—such as Hu Su (胡適), Chang King-wan (張君勱), Chen Tu-siu (陳獨秀), Ting Wen-kiang (丁文江), Wu Shih-hui (吳稚暉), Loh Chih-wei (陸志韋), Chang Tung-sun (張東蓀) and Chu King-lung (朱經農), on the very important and perplexing problem of "The Science and Philosophy of Life" (科學與人生觀). Two volumes of about two hundred and fifty thousand words have been written on this subject in connection with the debate. The themes of the contention were "Does a philosophy of life based upon mere scientific theories give the true meaning or meanings of life? Is the naturalistic interpretation of life a sufficient explanation of life in all its various aspects?" Mr. Chang King-wan started the discussion by stating that life, having its idealistic and intuitive aspects (as for instance expounded in the philosophies of Eucken and Bergson), is above the domain of science and the mechanistic interpretation of phenomena of science which cannot touch and should not touch the sphere of values and evaluation. Immediately after his lecture in Tsing Hua College, Mr. Ting Wen-kiang, himself a geologist, took issue with him. Then men like Wu Shih-hui, Hu Su and others followed suit. Strong thinkers on both sides contributed thought—provoking arguments. Since then another book has appeared namely the "Battle of the Philosophies of Life" (人生觀之論戰).

Search for Life

While the controversialists are primarily interested in the intellectual justification of

their views rather than in the results which naturalism or idealism is bound to produce in the conduct and spirit of the nation, they nevertheless reveal to us their consciousness of the nation's deep seated need of an adequate view of life for these times of rapid change. They show also an intellectual and practical turning away from the ethical and philosophical *theories* of China's past and an eagerness to build a view or a number of views of life on reasonable and scientific grounds. They manifest an acquaintance with Western systems of thought, which we realize were not so prevalent among Chinese scholars a few years ago. Most important of all, these men indicate to us two very urgent needs of the Chinese people to-day, (1) the need of a spiritual interpretation of life at a time when materialism is invading our land with such convincing force, and (2) the need of inculcating the spirit and methods of science in the minds of the Chinese people after long ages of generalizing and theorising. Tell them there is nothing beyond the naturalistic explanations of science and you will do them a lasting good. In all these contentions their influence upon both Christian and Non-Christian students is very great and should therefore challenge our sympathetic and creative thinking on the same problems to the end that we may present a consistent Christian Philosophy of Life to the nation that will be satisfactory both to reason and to the whole significance of life. This controversy means a very great deal to the Christian Movement in China.

Especially notable is Tsiang Po-li's book on **History** "The History of the European Renaissance" (蔣百里歐洲文藝復興史) which opens "a way to those who seek the morning light". Liang Chi-chao has a very high opinion of this book. Those who want to understand the Chinese Renaissance should read this book which, written in the Wen-li, gives hints of the motives behind the Chinese New Thought Movement. Then there is Chow Tso-jen's (周作人) "History of European Literature" (歐洲文學史) which traces the development of literature through Greek and Hebrew strata. Non-Christians understand the Bible at times far better than Christians who believe and yet do not know. Following these books in the order of value are Yih Chia I's "The Western Family" (易家鉞西

洋家庭), Hu Su's Essays (胡適文存), and Chen Tu-siu's Essays (獨秀文存).

Translations As far as translated books are concerned we find Bertrand Russell, Bergson, Dewey, Eucken, Einstein, Victor Hugo, Tagore, Tolstoi, Ibsen, Marx, Bernard Shaw, Maeterlinck, Driesche, McDovgall, Nietzsche, Darwin, Ellwood, and a long list of others in various lines in the book markets. Startling discourses in the periodical literary world are legion. Russian, Japanese, French, German, English, and Chinese literature mingle on the book shelves of many a reader to-day. All these are Non-Christian productions, translated by Non-Christian writers, some of whom are veteran scholars while many others are talented but amateur lovers of the pen. As it is not within the scope of this paper to mention the books produced by Christians or Christian literature societies, I pass them over without mentioning their contribution which is at present comparatively meagre and weak. Not is it possible to classify the subjects of the books that are being produced and that have been written by those in teaching work. Suffice it to say that there are now many books on socialism, on the duties of citizens, on labor problems, on women, children, and politics, on education, heredity, economics, biology, and other scientific subjects. Most Chinese colleges have their "Chung Shu" (叢書).

Women's Problems Two other things should be mentioned as they are doubtless of interest to foreign readers. There is now a set of six volumes on "The Woman's Problems". These six books are a compilation of articles published in various magazines and newspapers in the last few years from May 4, 1920, on. No one interested in the progress of Chinese women can afford to ignore the opinions and conceptions of the Chinese young men and women in regard to the problems of women. It is only possible to mention the main topics of the various articles published in these volumes. These are "The Emancipation of Woman"; "The Education of Women"; "The Economic Dependence and Independence of Women"; "The Political Rights of Women" or "Universal Suffrage for Women"; "The Problem of Child Birth"; "The Problem of Sex"; "Woman and the Home"; "The

Family"; "Marriage"; "Love"; "Divorce"; "Celibacy"; "The Modesty and Purity of Womanhood"; "Woman's Moral Life"; "The Public Education of Children"; "The Problem of Prostitution"; "The Problem of Female Slaves"; "The Mind of Woman"; "Hairdressing"; "Biographies of Noted Modern Women". Every one of these topics is of great significance to Chinese people at this time when old standards and moral sanctions are breaking down and new ideals of life have not as yet found clear expressions in the thought and conduct of the people.

Poetry Besides these books on woman and her problems, there is another kind in the writing of which both men and women collaborate. The Chinese Renaissance will miss its real function if it does not show creative power in the production of an entirely new kind of literature, especially poetry. There are many people who have decided, whether they fail or succeed, not to use the classical language or *wen-li* to convey their ideas. The *pei-hua* must conquer through use and through the faith of those who employ it for the expression of the best thoughts they have. The bone of contention for several years has been whether or not the *pei-hua* is the proper medium of poetic expression. Those who believe that no new poetry is possible in the *wen-li* have made more or less successful attempts to put real poetry into the *kuo-yü*. In spite of the fact that most of those who write in the *pei-hua* are well versed in the classical language they have purposefully abandoned the old way and gone over to this new way of writing poetry. China to-day is a forest full of such singing birds. To mention the most noted volumes of poems published recently, we have Miss Hsieh Ping Sing's (a graduate of Yen-Ching University Woman's College) "Numerous Stars" (謝冰心的繁星) a book of lyrical poems; Dr. C. W. Luh's (a graduate of Soochow University and of the University of Chicago, now head of the Department of Psychology, Southeastern University) "Crossing the Stream" (陸志章的渡河) a volume of social, religious, philosophical, and lyrical poems the technique of which none has yet beaten; Kang Bei Ching's (a graduate of the National University of Peking now studying in America) "The Grass" (康白情的草兒); Wong Chin Tse's (a

student of The Chinese Public School, Wusung, Shanghai) "The wind of Hui" (汪靜之的蕙的風); Yu Ping Pei's (a graduate of the National University of Peking, now teaching in certain schools) "Winter Nights" (俞平伯的冬夜); Kuo Mu Shih's (a returned student from a Japanese Medical School, now editor in the Tai-tung Book Company, Shanghai) "The Goddess" (郭沫若的女神); Wen I Tu's "Red Candle" (聞一多的紅燭) and others. Many are attempting to write poetry and while a goodly number fail, a considerable number succeed. Of the young poets we may mention, besides those already indicated, Hsu Chih Mu (徐志摩), Tang Shih (唐竣), Shen Ying Mu (沈尹默), Shen Chi Shih (沈兼士), Wong Ching Shi (汪敬熙), Chow Tsu Jen (周作人), Chow Tse Kai (周之幹), Li Da Tsai (李大釗), Yu She (余捷), Hu Su (胡適), Luh Yu Pei (陸友白, Mrs. Jen, (Miss Chen Hung Tsih) (陳衡哲), Miss Huang Wei (黃婉), Lu Chia Lun (羅家倫), Yih Shao Kying (葉紹鈞), Fu Nian Chang (傅彥長), Fu Shi Nian (傅斯年), Wang Chih Sui (王志瑞), Meng Suo Tsuan (孟壽椿), and many others. Their poems have been collected into volumes and have also appeared in different newspapers and magazines. The "Snowy Morning" (雪朝) published under the name of the Society for the study of Literature, and the Year of Poems (新詩年選) published under the name of the North Club, are typical poetical books of the times.

In addition to books of poetry we may say something in passing about books giving results of study of old Chinese poets. There are also books of short stories. Such books as Yih Shao Kying's "The Grass Man", "The Diaphragm" (葉紹鈞的草人與膈膜) are quite representative of the creative instinct. Then there are Yu Ping Pei's "An Argument in Regard to the Dream of the Red Chamber" (俞平伯的紅樓夢辨). The revival of the study of ancient literature is characteristic of the Renaissance movement also.

Let the reader be reminded that the books and authors mentioned in this article are those that the writer is personally best acquainted with. The list is very incomplete. It is all the more so because the writer's interest is narrow and selective of subjects. Literary activity together with activity in the provinces of science show a growth in the life of the nation which is most promising for the peace of the

people and of the world in spite of the fact that both Chinese politicians and foreign diplomatists are creating situations conducive to war, the increase of bandits in China and robbers elsewhere. It is only to be hoped that calamity howlers may see something of this peaceful vitality and that the Christian church may match this surging life with a corresponding activity which will supply a religious motive and a spiritual touch to the New Thought Movement.

CHAPTER LXXXIII

NEW PUBLICATIONS IN CHINESE, OCTOBER, 1922, AND SEPTEMBER, 1923

G. A. Clayton

The constant repetition of the same statement gets monotonous, and so the reader is referred to the headings of similar lists to this which have appeared in "The China Mission Year Book" for the reasons why this list is incomplete. Even though emphasis has this year been laid on the advantage which it is to a publisher to have his publications listed here, the necessary information has in many cases been supplied in an imperfect form.

Six years have elapsed since the "Index" was issued and a new edition would have been ready now if it had been possible for me to find the time needed for the final work on the manuscript. It is to be hoped that before September, 1924, the new edition will be on sale and that a supplementary list for the 1923-1924 period will not be needed.

In the case of two or three publishers I have included in this list books which were not issued during the period under review because their lists for last year arrived late.

As far as I know no new publisher has commenced work since October, 1923. The Methodist Publishing House has ceased its work as a Mission Press, but it is understood that it will continue as a publisher. And probably before another year has passed the Commercial Press will have started to issue Christian books as a part of its regular commercial activities.

The Christian Literature Society, Shanghai

- 啟示錄新註釋 254pp. Copy, 0.70
NEW COMMENTARY ON THE REVELATION OF ST. JOHN.
J. Leighton Stuart.
- 諸教參考 70pp. Copy, 0.15
COMPARATIVE RELIGION, by Kellogg. Trans. W. M. Hayes.

- 續小講台 106pp. Copy, 0.18
 TALKS FOR THE KING'S CHILDREN, by Stall.
- 查經要術 M. 20pp. Copy, 0.06
 HOW TO STUDY THE BIBLE. D. MacGillivray.
- 陳金鏞的佈道篇 125 sets, \$1.10
 CHEKIANG TRACTS. Chen Gin-yung. Fourth series of eight.
- 亂世女豪 124pp. Copy, 0.20
 ROMOLA, by George Eliot. Trans. Miss Laura M. White
- 女界良師 44pp. Copy, 0.12
 THE LIFE OF ALICE FREEMAN PALMER. Miss Mary Chen.
- 餐樓一夕話... .. 48pp. Copy, 0.08
 THE UPPER ROOM, by Ian Maclaren. Trans. D. MacGillivray.
- 約翰福音略解 234pp. Copy, 0.40
 STUDIES FOR STUDENTS FROM JOHN'S GOSPEL, by Speer. Trans.
 D. MacGillivray.
- 耶穌的社會原理 236pp. Copy, 0.35
 SOCIAL PRINCIPLES OF JESUS, by Rauschenbusch. Trans. C. S. C.
- 社會福音的神學 230pp. Copy, 0.40
 THEOLOGY FOR A SOCIAL GOSPEL, by Rauschenbusch. Trans.
 J. Speicher.
- 庫若索探險記 86pp. Copy, 0.15
 ROBINSON CRUSOE. Trans. I. Mason.
- 不是他們的耶穌 Copy, 0.04
 NOT THEIR JESUS. Chinese author.
- 佈道新軌 20pp. Copy, 0.10
 EVANGELISM. D. MacGillivray.
- 主禱詳解 64pp. Copy, 0.10
 RELIGION OF THE LORD'S PRAYER, by Poteat. Trans. E. N.
- 不可思議之思議 Copy, 0.30
 FROM THE SEEN TO THE UNSEEN. Miss L. M. White.
- 宣道的手冊... .. 52pp. Copy, 0.10
 MANUAL FOR PREACHERS. Evan Morgan.
- 得勝之人生... .. 24pp. Copy, 0.03
 THE LIFE THAT WINS, by Trumbull. Trans. H. K. Wright.
- 基督教社會上之標準二十五條 34pp. Copy, 0.03
 TWENTY-FIVE SOCIAL PRINCIPLES OF THE CHURCH. H. K.
 Wright.
- 尋求真實 54pp. Copy, 0.06
 QUEST FOR TRUTH. I. Mason.
- 聖經的宣召... .. 35pp. Copy, 0.25
 THE MESSAGE OF THE BOOK. A pageant, by Mrs. MacGillivray.
- 味腴演講集... .. Copy, 0.35
 FIFTY SERMONS. Chu Wei-yü

- 鬧市孤兒 98pp. Copy, 0.10
ALONE IN LONDON, by Hesperia Stretton. Trans. Mrs. MacGillivray.
- 最新真道問答 48pp. Copy, 0.05
NEW METHOD CATECHISM. C. N. Ogilvie.
- 畢生忠勇(但以理)... .. 56pp. Phon. Copy, 0.05
Man. Copy, 0.10
A TRUE HERO—DANIEL. Mrs. MacGillivray.
- 大首領(摩西) 58pp. Man. Copy, 0.10
70pp. Phon. Copy, 0.05
A GREAT LEADER—MOSES. Mrs. MacGillivray.
- 我的圖畫書... .. 80pp. Copy, 0.60
FLAG PICTURE BOOK. Mrs. MacGillivray.
- 月份牌 100, 9.00
ART CALENDAR FOR 1924.
- 耶穌爲小孩子祝福的五色圖 Sheet, 0.10
CHRIST BLESSING THE CHILDREN, by Harold Copping.
- 福音和合 192pp. Copy, 0.30
NEW HARMONY OF THE GOSPELS, in Wenli.
- 共產主義 24pp. Copy, 0.10
THE PARCICAL STATE OF COMMUNISM. H. K. Wright.
- 舊約歷史 194pp. Copy, 0.25
OLD TESTAMENT HISTORY for the use of Middle Schools.
H. K. Wright.
- 人生之將來... .. Man. 58pp. Copy, 0.10
QUIET TALKS ON LIFE AFTER DEATH, by S. D. Gordon.
Trans. D. MacGillivray.
- 永生證 Copy, 0.08
ASSURANCE OF IMMORTALITY, by Fosdick. Trans. D.
MacGillivray.
- 狄公事略 28pp. Copy, 0.08
LIFE OF ROBERT MATEER.
- 城市衛生學... .. 138pp. Copy, 0.30
CIVIC HYGIENE, or sanitation for town and country.
- 將往何處 116pp. Copy, 0.20
QUO VADIS, by Sienkiewicz. Trans. Miss L. M. White.
- 聖誕故事 50pp. Copy, 0.10
CHRISTMAS STORIES, by "Happy Childhood."
- 莫包脚歌 100, 0.15
ODE AGAINST FOOTBINDING.
- 女子的真進步 18pp. 100, 2.00
STEP LIVELY. A story against toot-binding.
- 放脚歌
UNBIND! UNBIND! Anti-footbinding song.

- 復原教創始記 Man. 40pp. Copy, 0.08
 THE RELIGIOUS PRINCIPLES OF THE REFORMATION, by Lindsay.
 Trans. H. K. Wright.
- 求則得之 Man. 38pp. Copy, 0.06
 ANSWERS TO PRAYER, by Trumbull.
- 家範溯源 Man. 102pp $\frac{1}{2}$. Copy, 0.15
 QUIET TALKS ON HOME IDEALS, by Gordon. Trans. D.
 MacGillivray.
- 祈禱學 Man. 168pp. Copy, 0.30
 WITH CHRIST IN THE SCHOOL OF PRAYER, by Andrew
 Murray. Trans. Hopkyn Rees.
- 八福詳解 Man. 48pp. Copy, 0.10
 STUDIES ON THE SERMON ON THE MOUNT, by King. Trans.
 D. MacGillivray.
- 凡民聖律 Man. 58pp. Copy, 0.10
 LAWS OF CHRIST FOR COMMON LIFE, by R. W. Dale.
- 地球一百名人 Man. 260pp. Copy, 0.45
 ONE HUNDRED FAMOUS MEN. Selections.
- 衛生歌八種... .. 100, 0.80
 HYGIENE SONGS—eight songs.
- 強種須知 Man. 62pp. Copy, 0.12
 CHINA'S ENEMIES. Temperance stories by Miss C. I.
 Tinling.

Church Literature Committee, Peking and Shanghai

- 童性學 34pp. W. Copy, 0.10
 CHILD PSYCHOLOGY, by L. A. Weigle. Trans. S. C. Yang.
- 經義紺珠 172pp. W. Copy, 0.30
 SCRIPTURE TREASURES. Sixty sermons by Wang Ping-ji.
- 聖經入門卷二新約... .. 180pp. W. Copy, 0.40
 INTRODUCTION TO THE HOLY SCRIPTURES, New Testament.
 L. B. Ridgely.
- 善人遭難 110pp. M. Copy, 0.10
 THE TROUBLES OF THE RIGHTEOUS, being the book of Job
 arranged by Moulton. Arr. L. B. Ridgely.
- 蘭柏會議 70pp. W. Copy, 0.15
 THE LAMBETH CONFERENCE, 1920. Encyclical letter and
 resolutions.
- 蘭柏會議說明書 32pp. M. Copy, 0.10
 A TRACT ON THE LAMBETH APPEAL AND RESOLUTIONS.
- 使徒信經條解 158pp. M. Copy, 0.30
 INTRODUCTION TO THE APOSTLE'S CREED. Lin Pu-chi.
- 基督論衡 164pp. W. Copy, 0.30
 LIFE OF CHRIST, by Sanday. Trans. M. H. Throop.

- 山訓詮真 134pp. M. Copy, 0.15
 THE SERMON ON THE MOUNT, by Bishop Gore.
- 舊約文學小史 218pp. W. Copy, 0.30
 A SHORT HISTORY OF THE LITERATURE OF THE OLD TESTAMENT.
 Lin Pu-chi.
- 國民被審得救 272pp. M. Copy, 0.15
 A NATION TRIED AND SAVED, being the Book of Isaiah
 arranged by Moulton. Arr. L. B. Ridgely.
- 學牧問津 130pp. W. Copy, 0.20
 THE MINISTRY, by Bishop Slattery.

The Association Press, Shanghai

- 宗教與科學... .. 206pp. Copy, 0.45
 RELIGION AND SCIENCE. Trans. Timothy Jen.
- 談道錄 49pp. Copy, 0.10
 A DIALOGUE ON CHRISTIANITY, by A. G. Adams. Trans.
 Timothy Jen and Wei Sung-kao.
- 道原... .. 110pp. Copy, 0.20
 GOD AND MAN. Based on Swain's "What and where is
 God?" N. Z. Zia.
- 艾迪博士與勞工問題 63pp. Copy, 0.10
 SHERWOOD EDDY AND THE LABOR QUESTION. Y. K. Woo.
- 歐遊經驗談... .. 101pp. Copy, 0.25
 EXPERIENCES AND OBSERVATIONS IN EUROPE. Edited by
 Y. K. Woo.
- 宗教與人生... .. 138pp. Copy, 0.25
 RELIGION AND LIFE. Trans. Timothy Jen.
- 基督教是什麼 28pp. Copy, 0.04
 WHAT IS CHRISTIANITY? T. L. Shen.
- 宗教與進化論 32pp. Copy, 0.05
 EVOLUTION, THE BIBLE AND RELIGION. Trans. Y. K. Woo.
- 晨更經題 38pp. Copy, 0.07
 DAILY BIBLE READINGS. Trans. C. S. Chen.
- 梵天觀感錄... .. 27pp. Copy, 0.10
 INDIA THROUGH CHINESE EYES. T. Z. Koo.
- 青年會樂語... .. 22pp. Copy, 0.06
 THE FUTURE OF THE Y. M. C. A. Y. K. Woo.
- 美滿生活是什麼 20pp. Copy, 0.05
 WHAT IS THE IDEAL LIFE? T. C. Chao.
- 苦厄問題 29pp. Copy, 0.05
 THE PROBLEM OF SUFFERING, by Fosdick. Trans. Y. K. Woo.

Edward Evans and Sons, Ltd., Shanghai

- 實用公民學卷一 Copy, 1.35
 CIVICS, PART 1. Recreation, health, protection. D. H. Kulp.
- 中國衛生教科書 Copy, 0.30
 HYGIENE AND SANITATION FOR CHINA, by Rithie-Purcell.
 Trans. V. N. Appleton.
- 理科實驗法... .. Copy, 0.40
 GENERAL SCIENCE LABORATORY MANUAL. F. C. Mabce
 and Zee Tsoh-wu.

China Christian Endeavour Union, Shanghai

- 勉勵會祈禱會題目... .. 100, 0.35
 C. E. TOPIC SHEETS.
- 勉勵會簡義... .. Copy, 0.03
 BEGINNERS TOPIC BOOK FOR 1924. Miss J. Anderson.
- 勉勵會講義... .. Copy, 0.05
 HINTS AND HELPS BOOK. J. Vale and Chai Lien-fu.

Signs of the Times Publishing House, Shanghai

- 拾級就主 W. 112pp. Copy, 0.18
 STEPS TO CHRIST, by Mrs. E. G. White.

The Mission Book Co., Shanghai

- 喻道瑣談 Copy, 0.40
 ILLUSTRATIONS FOR PREACHERS, by T. C. Li and R. Y. Lo.
- 基督教與新中國 Copy, 0.18
 CHRISTIANITY AND NEW CHINA, by R. Y. Lo.
- 教友十課 Copy, 0.12
 TEN LESSONS FOR CHURCH MEMBERSHIP, by R. Y. Lo and
 Nelson Li.
- 破除迷信叢書 Each vol, 0.14
 THE SUPERSTITION SERIES, by T. C. Li and R. Y. Lo.

- No. 1 Fungshui. 風水
 2 Soothsaying. 卜筮
 3 Physiognomy. 看相
 4 Extraordinary Phenomena.

- 聖經新詩 Copy, 0.15
 BIBLICAL POEMS, by Li Chuan-kiai.
- 中華基督教會 Copy, 0.25
 THE CHRISTIAN CHURCH IN CHINA, by Gustav Koll and
 Tai Chun-san.
- 檢定教會設立初等小學要法 Copy, 0.10
 SOME FACTORS IN THE EVOLUTION OF CHRISTIAN LOWER
 PRIMARY SCHOOLS, by Ida B. Lewis.
- 續婚鑑 Copy, 0.15
 A STEPMOTHER, by Kwang Yü.
- 教授主日學的我見... .. Copy, 0.12
 MY SUNDAY TEACHING, trans. from J. R. Lamb.
- 東方民族改造論 Copy, 0.60
 by Chang Chun-dziin.
- 墨學與景教... .. Copy, 0.25
 by Chang Chun-yi.
- 墨子閒話箋... .. Copy, 0.90
 by Chang Chun-yi.
- 頌主詩歌附篇琴譜... .. Copy, 0.70
 SUPPLEMENTARY HYMNS FOR THE BLODGET-GOODRICH HYMNAL,
 with music.
- 宗教教育教授法 Copy, 0.10
 METHODS OF TEACHING RELIGIOUS EDUCATION, by D. P. King.

H. C. G. Hallock, Shanghai

- 五十二主日聖經講義二集... .. Copy, 0.50
 FIFTY-TWO SERMONS—SECOND SERIES.
- 日用指明 Copy, 0.05
 HALLOCK'S ALMANAC FOR 1924.

West China Christian Educational Union, C. M. M. Press. Chungking

- 初小聖經教授法 W. Set, 0.44
 TEACHERS' HANDBOOKS—LOWER PRIMARY SCRIPTURE.
 Years one to four, sold separately. Year 1, 81pp.,
 0.12. Year 2, 45pp., 0.12. Year 3, 46pp., 0.10.
 Year 4, 40pp., 0.10.
- 中學聖經科要目 40pp. W. Copy, 0.15
 SYLLABUS—MIDDLE SCHOOL SCRIPTURE.
- 初小地理科要目 6pp. W. Copy, 0.04
 SYLLABUS—LOWER PRIMARY GEOGRAPHY.

- 高小地理科要目 18pp. W. Copy, 0.06
SYLLABUS—HIGHER PRIMARY GEOGRAPHY.
- 中學地理科要目 11pp. W. Copy, 0.06
SYLLABUS—MIDDLE SCHOOL GEOGRAPHY, 1st. and 2nd. years.
- 國文實用科要目 8pp. W. Copy, 0.03
SYLLABUS—LOWER PRIMARY PRACTICAL CHINESE.
- 國文科要目... .. 17pp. W. Copy, 0.05
SYLLABUS—CHINESE LANGUAGE.
- 數學科要目... .. Copy, 0.05
SYLLABUS—ARITHMETIC.
- 中學圖畫科要目 6pp. W. Copy, 0.03
SYLLABUS—MIDDLE SCHOOL DRAWING.
- 女子中學家政科要目 18pp. W. Copy, 0.06
SYLLABUS—MIDDLE SCHOOL DOMESTIC SCIENCE.
- 中學新課程綱要 30pp. W. Copy, 0.05
MIDDLE SCHOOL CURRICULUM.
- 初小新課程綱要 Copy, 0.07
LOWER PRIMARY CURRICULUM.
- 耶穌言行錄... .. 133pp. M. Copy, 0.11
WORDS AND ACTS OF JESUS—Lower Primary Third Year
Scripture Reader.
- 使徒言行錄... .. 53pp. M. Copy, 0.12
WORDS AND ACTS OF THE APOSTLES—Lower Primary Fourth
Year Scripture Reader.
- 初小聖經頌 27pp. M. Copy, 0.05
LOWER PRIMARY SCRIPTURE MEMORIZATION PASSAGES.
- 高小聖經頌 33pp. Copy, 0.10
HIGHER PRIMARY SCRIPTURE MEMORIZATION PASSAGES.
- 學校遊戲法... .. 54pp. Copy, 0.09
SCHOOL GAMES, by T. P. Chang.
- 里奴童話 30pp. Copy, 0.10
UNCLE REMUS, trans. A. H. Wilkinson.
- 一年經驗 31pp. Copy, 0.18
ONE YEAR'S EXPERIENCE IN THE DEWEY PRACTICE SCHOOL.
- 小說寓言 18pp. Copy, 0.06
PHONETIC READER FOR PRIMARY SCHOOLS.
- 初小地理教科書 118pp. Copy, 0.25
LOWER PRIMARY GEOGRAPHY, by R. J. Davidson.
- 中學地理教科書 158pp. Set, 0.70
MIDDLE SCHOOL GEOGRAPHY NOTES, by R. J. Davidson.
Two vols.
- 中國名人傳... .. Sheet. Copy
LIST OF HEROES FROM CHINESE HISTORY.

- 外史... .. 133pp. Set,
FOREIGN HISTORY NOTES, by H. F. Rudd. Two vols.
- 養成教員書... .. 13pp. W. Copy, 0.06
TEACHING THE TEACHER TO TEACH.

Young Women's Christian Association, Shanghai

- 聖經之如何成就 Copy, 0.45
HOW THE BIBLE CAME TO BE, by Daisy R. Brown.
- 基督之道 Copy, 0.30
THE WAY OF JESUS, by Jean G. Paxton.
- 婦女於建國所處之地位 Copy, 0.25
THE PLACE OF WOMEN IN ESTABLISHING A NATION, by
Winifred Jacob. The student's leaflet costs 8 cents.
- 耶穌是我的唯一良友 Copy, 0.15
KNOWING JESUS AS A FRIEND.
- 晨更研究篇... .. Each, Copy, 0.09
STUDIES FOR THE MORNING WATCH, by Winifred Jacob.
Two vols.
- 合羣遊戲 Copy, 0.10
GAMES FOR GROUP RECREATION. Adapted from Bancroft.
- 徒手操教材... .. Copy, 0.70
GRADED GYMNASTIC EXERCISES. Adapted from W.
Skarstrom. Edit. Mrs. D. Y. Lin.
- 基督與吾祖國 Copy, 0.10
CHRIST AND OUR COUNTRY—a pageant by Frances Chang.
- 聖誕表演 Copy, 0.08
THE CHRISTMAS STORY—a pageant from Ben Hur.
- 四個博士 Copy, 0.15
THE OTHER WISE MAN—a pageant from Van Dyke.
- 復活節戲劇... .. Copy, 0.06
AN EASTER PLAY.
- 益智叢談 Copy, 0.20
TELL ALOUD TALES.
- 世界中綱英雄傳 Each, 20pp. M. Set. 0.50
STORIES OF WOMEN PIONEERS, compiled by students of
Ginling College. Eight vols.:—Jane Addams,
Anna Howard Shaw, Kaji Yajima, Florence
Nightingale, Grace H. Dodge, Catherine Bresh-
kovsky, Mary Slessor and Mary Lyon.

West China Religious Tract Society, Chungking

- 勸士歸主俗歌 Sheet. 100, 0.15
SONG FOR SCHOLARS, by Lin I-tien and Lui Chen-dao.

勸農歸主俗歌 Sheet.	100, 0.15
SONG FOR FARMERS, by Lui Chen-dao.	
勸工歸主俗歌 Sheet.	100, 0.15
SONG FOR WORKMEN, by Lui Chen-dao.	
異常貨品 Sheet.	100, 0.15
SONG FOR MERCHANTS, by Lin I-tien and Lui Chen-dao.	
勸工商敬拜上帝 Sheet.	100, 0.06
SONG EXHORTING WORKMEN AND MERCHANTS, by Mao Tsoh-san.	
抗穀子 Sheet.	100, 0.06
ON LYING, by Mao Tsoh-san.	
迷信辯明歌... .. Sheet.	100, 0.15
ENLIGHTENING THE DECEIVED, by Tang Sao-kwei.	
女界除迷歌... .. Sheet.	100, 0.15
TO UNDECEIVE WOMEN, by Tang Sao-kwei.	
播揚喜信 Sheet.	100, 0.10
GOOD NEWS LETTER, adapted from Dr. Mabie by Lui Chen-dao.	
說羊指人 Sheet.	100, 0.10
MEN LIKE SHEEP, by Lui Chen-dao.	
毒種須知 Sheet.	100, 0.10
BEWARE OF GERMS, by C. L. Kilborn.	
何謂得救 Sheet.	100, 0.10
WHAT IS SALVATION, based on A. T. Pierson by Lui Chen-dao.	
最好朋友 Sheet.	100, 0.10
THE BEST FRIEND. Story of Damon and Pythias by Lui Chen-dao.	
兩次照像 Sheet.	100, 0.10
THE TWO PHOTOGRAPHS. Adapted from Dr. Mabie by Lui Chen-dao.	
何爲真教 Sheet.	100, 0.10
THE TRUE RELIGION, by Bishop Whipple. Trans. Lui Chen-dao.	
圖畫八種 Sheets.	100, 0.50
EIGHT LARGE COLORED PICTURE TRACTS. Abraham, Joseph, Moses, David, Elijah, Daniel, the Nativity and the Widow's Mite.	

The Lutheran Board of Publication, Shekow, Hup.

新約歷史 170pp.	M. Copy, 0.30
BIBLE HISTORY, NEW TEST. FOR SECONDARY SCHOOLS E. Folke.	

- 聖道講臺 129pp. M. Copy, 0.30
SERMONS, by I. Daehlin.
- 聖教史徵 81pp. W. Copy, 0.15
HISTORY OF THE PREPARATION FOR CHRISTIANITY, by E.
Sihvonen.
- 信條學 W. 2 vols. 316pp. Set, 0.60
SYMBOLICS, by E. Sihvonen.
- 信義月份牌... .. Sheet. 109, 2.30
THE LUTHERAN CALENDAR.
- 中華信義會區會章程 W. Copy, 0.02
CONSTITUTION FOR LOCAL CONGREGATIONS of the Lutheran
Church in China.
- 中華信義會公會章程 W. Copy, 0.02
CONSTITUTION FOR DISTRICTS.
- 教友證書 Set of 50, 2.00
CERTIFICATE OF BAPTISM, printed in three colors.

Kwang Hsiieh Publishing House, Shanghai

- 泰西哲學引階目錄... .. 112pp. W. Copy, 0.35
AN INTRODUCTION TO WESTERN PHILOSOPHY, by J. Percy
Bruce.
- 算術教科書... .. W. Vols sold separately
A HIGHER ARITHMETIC FOR SCHOOLS, by Cheng Yü-tzu.
Vol. 2, 0.40; vol. 3, 0.60; vol. 4, 0.40; vol. 5, 0.40;
vol. 6, 0.40.
- 體功學問答 48pp. Copy, 0.12
QUESTIONS AND ANSWERS IN ELEMENTARY PHYSIOLOGY.
MUSIC PUBLISHED FOR THE HANGCHOW CHORAL UNION.
Edit, K. C. Wang.
- 哈利路亞 4pp. Copy, 0.10
The Hallelujah Chorus.
- 美哉聖羔 3pp. Copy, 0.10
Worthy is the Lamb.
- 基督復活 4pp. Copy, 0.10
He who slumbered.
- 我是復活重生... .. 7pp. Copy, 0.16
I am the Resurrection.
- 白墓復生及爲主力戰... .. 4pp. Copy, 0.10
Christ Arose, Onward, Christian soldiers.
- 興起發光及凡屬信主門徒 4pp. Copy, 0.10
Choir Selection, No. 1. Arise Shine, O come all ye
faithful.

Nurses' Association of China.

Kwang Hsüeh Publishing House, Shanghai

- 實用護病學... .. Vol. 1, part 1. W. 194pp. Copy,
 PRACTICAL NURSING, by Anne C. Maxwell and Amy E.
 Pope trans. by K. E. Wood and G. Y. Zwun.
- 護士倫理學... .. 24pp. Copy, 0.10
 STUDIES IN ETHICS FOR NURSES, by C. Aikens, trans. by
 C. Wellwood and K. C. Wang.
- 看護藥科學... .. W. 534pp. Set, 3.25
 MATERIA MEDICA FOR NURSES, by Blumgarten. Trans.
 E. Margaret Phillips.
- 陰陽尿具及花柳症簡編... .. W. 34pp. Copy, 0.20
 NOTES ON GENITO-URINARY NURSING, by K. E. Wood and
 G. Y. Zwun with supplement by Dr. Kao.
- 體學與體功學問答... .. W. 70pp. Copy, 0.20
 QUESTIONS AND ANSWERS ON BUNDY'S ANATOMY AND
 PHYSIOLOGY, by Mrs. Logan.
- 飲食學問答... .. W. 34pp. Copy, 0.12
 QUESTIONS AND ANSWERS ON FRIEDENWALD AND RUHRAH'S
 DIETETICS for Nurses, by Mrs. J. M. Logan.
- 產科學問答... .. W. 38pp. Copy, 0.12
 QUESTIONS AND ANSWERS ON DR. LEE'S OBSTETRICS FOR
 NURSES, by Mrs. Logan.
- 豪慈小兒科問答... .. W. 32pp. Copy, 0.12
 QUESTIONS AND ANSWERS ON CHILDRENS' DISEASES, by
 Mrs. Logan and S. H. Chen.

University of Nanking, Nanking

- METHODS OF SILKWORM REARING FOR FARMERS, by Kuh
 Ying.
- HANDBOOK OF SERICULTURE, by Kuh Ying.
- SILKWORM BREEDING, by C. L. Chien.

Daily Vacation Bible School Movement, Shanghai

- 教員指南... .. 74pp. M. Copy, 0.20
 TEACHER'S MANUAL, by R. G. Boville. Trans. C. T. Bau.
- 代答... .. 26pp. M. 5 Copies, 0.03
 HANDBOOK.
- 夏令兒校教科單張... .. 35pp. M. Copy, 0.20
 TEXTBOOK FOR D. V. B. S.
- 夏令兒校全國報告書... .. 33pp. M. Copy, 0.10
 NATIONAL REPORT.
- 52pp. M. Copy, 0.30
 MANUAL AND HANDBOOK.

China Baptist Publication Society, Canton

- BAPTISTS AND THEIR BUSINESS, by J. B. Gambell. Trans. C. J. Lowe.
- MODERN ECLIPSE OF CHRISTIANITY, by E. Y. Mullins. Trans. E. L. Morgan.
- PREACHERS AND MODERN CRITICISM, by D. F. Stampe.
- THE PRESENT SITUATION IN THEOLOGY, by E. Y. Mullins. Trans. E. L. Morgan.
- THE CREED OF AN EMINENT SCIENTIST, by H. A. Kelly. Trans. E. L. Morgan.
- SUNDAY SCHOOL NORMAL MANUAL, Trans. Pinston Hsu.
- BAPTIST YOUNG PEOPLE'S MANUAL, Trans. Joshua Djaw.
- NEED OF CHRISTIANITY IN THE PRESENT WORLD, by E. Y. Mullins. Trans. E. L. Morgan.
- DISCUSSING CHRISTIANITY WITH CHEN AND TSEN, by Chang Wen-kai.

Friends' Council for International Service, Isaac Mason., Shanghai.

- 生活的準則... .. M. 26pp. Copy, 0.02
- A FAITH TO LIVE BY, by Gulielma Crostfield. Trans. I. Mason.
- 尋求真實 56pp. Copy, 0.06
- THE QUEST FOR TRUTH, by Prof. Silvanus P. Thompson. Trans. I. Mason.

Religious Tract Society for China, Hankow and Shanghai.

- 猶太光復志演義 44pp. M. Copy, 0.08
- A SKETCH OF JEWISH HISTORY TO THE PRESENT DAY, by Chai Lien-fu.
- 舊約寓意 132pp. M. Copy, 0.20
- HIDDEN PICTURES, by Miss Habershon. Trans. Harry Price.
- 聖經典故二十四段... .. 74pp. M. Copy, 0.08
- TWENTY-FOUR STORIES FOR MASS MOVEMENT WORKERS, by G. and M. Ingram and R. John. Trans. Shen Wen-ching.

- 培靈引解創世記卷三 156pp. M. Copy, 0.20
 DEVOTIONAL COMMENTARY ON GENESIS, by G. Thomas.
 Trans. J. Vale and Chai Lien-fu. Volume 3.
- 培靈引解羅馬書卷一 174pp. M. Copy, 0.20
 DEVOTIONAL COMMENTARY ON ROMANS, By. G. Thomas.
 Trans. J. Vale and Chai Lien-fu. Volume 1.
- 以賽亞讀法準繩 179pp. M. Copy, 0.20
 HOW TO STUDY ISAIAH 1 — 39, based on Blake by G. A.
 Clayton.
- 啓示錄附註... .. 124pp. M. Copy, 0.20
 NOTES ON REVELATION, by Adam Grainger.
- 理家要錄 24pp. M. Copy, 0.03
 DUTY OF PARENTS TO THEIR CHILDREN, by Mrs. Dr. Kip.
- 速如其來 9pp. M. 10), 0.50
 DO YOU KNOW? Trans. J. Vale and Chai Lien-fu.
- 聖光夜導 378pp. M. Copy, 0.60
 DAILY LIGHT ON THE DAILY PATH, EVENING PORTIONS,
 arranged by Mrs. F. A. Clayton.
- 每年讀新約詩篇捷徑 26pp. M. Copy, 0.05
 ONE A YEAR — NEW TESTAMENT AND PSALMS. Arranged
 by G. A. Clayton.
- 聖會聯帖 10pp. W. Copy, 0.04
 CHRISTIAN ANTI-THETICAL COUPLETS. Prepared by a
 Committee.
- 會堂中的儀節 5pp. M. 100, 0.40
 MANNERS AT CHURCH, by Miss Wiggin. Trans. M. T.
 Liang.
- 至於我和我家 Sheet. Copy, 0.05
 AS FOR ME AND MY HOUSE. Written by Shen Gioh-su.
- 威廉約翰布道做船記 92pp. M. Copy, 0.12
 JOHN WILLIAMS, THE MISSIONARY BOAT-BUILDER. Trans.
 Mrs. A. Foster.
- 一貴友 10pp. M. Copy, 0.02
 MARIA VINCENT, by Dr. Schofield. Trans. J. Vale and
 Chai Lien-fu.
- 車中人語 8pp. M. Copy, 0.02
 A TRAIN JOURNEY, by Dr. Schofield. Trans. J. Vale and
 Chai Lien-fu.
- 文士歸主記... .. 7pp. M. 10), 0.50
 THE CONVERSION OF A CONFUCIANIST. Trans. J. Vale and
 Chai Lien-fu.
- 學生悟道 10pp. M. Copy, 0.02
 A SCHOOLBOY'S EXPERIENCE, by Dr. Schofield. Trans.
 J. Vale and Chai Lien-fu.
- 同樂家 35pp. M. Copy, 0.05
 ONE IN JOY, by Miss F. E. Gooch.

- 蚊蟲報仇 7pp. M. 100, 1.50
A LOUSE'S REVENGE, by Chai Lien-fu.
- 死裏還生 34pp. W. Copy, 0.04
LITTLE ANNA MARCK. Trans. Miss L. Forbein and Hsu
Hsien-yung.
- 眞神大道易學 Each vol. 16pp. M. 100, 1.80
SIMPLE TEACHING ABOUT THE TRUE GOD, by Mrs. B. C.
Patterson. Two vols.
- 基督教問答初學 30pp. M. Phon. 100, 260
CATECHISM FOR ENQUIRERS, by C. N. Lack. Phon. by
E. Weller.
- 注音頌主聖詩(六十五篇)... .. Copy, 0.05
R. T. S. PHONETIC HYMNAL, 65 Hymns.
- 輔讀行傳之方法 13pp. M. Copy, 0.03
OUTLINE HELPS FOR STUDYING THE ACTS, by E. Rowlands.
- 四書上下論... .. 82pp. W. Copy, 0.09
THE FOUR BOOKS—THE ANALECTS.
- 四書上孟 58pp. W. Copy, 0.07
THE FOUR BOOKS—MENCIUS, SHANG.
- 四書中下孟... .. 77pp. W. Copy, 0.07
THE FOUR BOOKS—MENCIUS, DJUNG AND HSIA.
- 破夢解迷 11pp. W. 100, 1.50
FOUR ERRORS EXPOSED, by Wang Geng-chen.
- 勸戒鴉片歌... .. 4pp. M. 100, 0.25
ANTI-OPIMUM BALLAD, by Hwang Shih-gia.
- 戒賭回頭歌... .. 8pp. M. 100, 1.20
THE GAMBLER'S HOPE, by Yuan Deh-lin.
- 神救人的妙法 28pp. M. Copy, 0.04
GOD'S WAY OF SALVATION, by Alexander Marshall.
Trans. Harry Price.
- 主必再來 14pp. M. 100, 1.60
SURELY HE WILL COME AGAIN, by Mercer. Trans.
J. Darroch.
- 終不能免分別 11pp. M. 100, 2.00
THE ESSENTIAL DIFFERENCE, by Mercer. Trans. J. Darroch.
- 竹子比喻 6pp. M. Copy, 0.01
THE BAMBOO—A PARABLE, by Mrs. Woodford Taylor.
- 替我受死的人 9pp. M. 100, 0.70
THE MAN WHO DIED FOR ME, by Mrs. C. C. Selden and
J. Vale.

- 廣報眞理 恩歸大衆 ... 5pp. M. 100, 0.30
 HERALDS OF TRUTH, SET. L.
- Sin and its remedy. 惡毒流行
 Look and live. 一望而活
 The blood of the Atonement. 救贖的血
 Victory over death. 得勝死權
 The place for burdens. 罪擔解脫
 Christ's rejectors judged. 棄恩受審
- 眞朋友 ... 7pp. M. 100, 0.60
 THE TRUE FRIEND, by Yang Chi-chen.
- 傾蓋良友 ... 7pp. M. 100, 0.60
 A CLOSE FRIENDSHIP, by Miss E. B. French and Liu
 Deh-hui.
- 如何拜眞神... 6pp. M. 100, 0.50
 HOW TO WORSHIP THE TRUE GOD, by Dr. F. H. Judd.
- 車夫樂恩歌... 8pp. M. 100, 0.50
 A BALLAD FOR RICKSHA COOLIES, by Miss F. E. Gooch.
- 基督教論文... 5pp. M. 100, 0.40
 A NOTICE ABOUT THE CHRISTIAN CHURCH, by Huang
 Shih-gia.
- 靈路碑 ... 10pp. M. 100, 0.70
 A SPIRITUAL SIGN-POST, by Rao En-djao.
- 接財神 ... 6pp. M. 100, 0.70
 ON SEEKING RICHES, by Rao En-djao.
- 智愚解 ... 8pp. M. 100, 0.70
 WISDOM AND FOLLY, by Rao En-djao.
- 求主開化我的心 ... Sheet. M. 100, 0.15
 LORD, OPEN MY HEART.
- 感謝主耶穌... Sheet. M. 100, 0.35
 THANKS BE TO JESUS.
- 天道大略 ... Sheet. M. 100, 0.50
 HEAVENLY TEACHING IN OUTLINE.
- 天堂歌 ... Sheet. M. 100, 0.35
 HEAVEN—MINE, THINE, HIS.
- 慈悲天父保佑一夜... Sheet. M. 100, 0.20
 MORNING PRAISE.
- 浪子回頭詞... Sheet. M. 100, 0.30
 PRODIGAL, RETURN.

帶聖經歌	Sheet.	M. 100,	0.40
THE POCKET TESTAMENT HYMN.			
恩歸大眾	Posters.	M. Set,	0.28
THE GRACE FOR ALL SERIES OF POSTERS.			
Sin and its remedy. 惡毒流行			0.04
Look and live. 一望而活			0.04
The blood of the atonement. 救贖的血			0.04
Victory over death. 得勝死權			0.08
The place for burdens. 罪擔解脫			0.04
Christ's rejectors judged. 棄恩受審			0.04
白話月份牌... .. .	Poster.	M. 100,	0.80
SHEET CALENDAR FOR 1923.			

CHAPTER LXXXIV

BOOKS ON SEX AND FAMILY LIFE

Eleanor MacNeil

TOWARDS RACIAL HEALTH. Norah H. March Routledge & Sons 5/-

"A Handbook for parents, teacher, and social workers on the training of boys and girls," written by a teacher of wide experience.

A very useful book, sane in its biology, ethics and psychology. The whole subject of sex is presented from the racial viewpoint in a way to appeal to children and adolescents. The imaginary conversations in sex education will be of value to parents. There is an excellent bibliography.

SEX. Geddes and Turner Home, University Library, Williams and Norgate

A simple and normal biological presentation with good chapters on the Ethics of Sex and Sex and Society. A good bibliography.

SEX AND COMMON SENSE. Author A. Maude Royden. Publisher Hurst and Blackett London Price 4/6

The book comes at an apt moment when questions of marriage, morality and birth control are being discussed. Never was there greater need for light and clear speaking on matters that have been kept too much in the background. Miss Royden is not afraid to speak plainly; she has the courage to examine, particularly from the woman's point of view, questions on which women too long have been silent.

A strong book, suitable either for the adult or adolescent reader, entirely Christian in its treatment of these important subjects.

MEN, WOMEN AND GOD. A. Herbert Gray. Association Press or Student Movement Press75 gold

A discussion from the Christian viewpoint, frank and wholesome, and certain to help a variety of perplexities. Chapters such as those on Involuntary Celibacy, The art of being married, A man's struggle, A girl's early days, are written with wide knowledge and understanding of people. Many critics have pronounced this the best book of its kind which has appeared. There is an appendix giving the physical facts of sex union which some would perhaps consider unnecessary for an immature mind.

SEX AND LIFE. Galloway Association Press \$1.80 gold

This book treats the problem of sex as a matter for intelligent education, and interprets it in its spiritual as well as physical values. It is written specially for men, and succeeds in being idealistic without being sentimental.

THE CONTROL OF PARENTHOOD. Edited by Sir James Marchant Putnam 6/-

A symposium by well known people in England, giving the arguments for and against birth control, from the individual, economic, social and religious standpoints, and therefore a help to clear thinking on this subject.

RATIONAL SEX LIFE. Author Exner Y. M. C. A. Association Press.

An excellent treatise on this subject by a Christian physician. Do not send your boy away to college without this book, or the information which it contains.

"OUTWITTING OUR NERVES." Authors Jackson and Salisbury Publisher The Century Co.

A primer of psychotherapy, providing enough of biological and psychological background to make the Freudian principles intelligible, and enough application and illustration to make them useful to the average layman.

In the experience of one physician this very readable and entertaining book has helped many missionaries to find health through a restored nervous balance.

MARRIED LOVE. Marie Stopes, Putnam's Sons 6/-

This book deals with the Sex-hygiene of Married Life.

The Atheneum says "Mrs. Stopes treats with frankness and insight of the ideals of perfect companionship and the obstacles thereto, of mutual adjustment, healthy married intercourse, and the other chief factors in the problem of conjugal happiness. Her book is one of the most sensible we have met with on the subject."

RADIANT MOTHERHOOD. Marie Stopes Putnam's 6/-

A book for mothers- and fathers-to-be, full of information of value, and a help to mutual understanding.

While Dr. Stopes is well known as an advocate of birth control, in which many people will not agree with her, these two books have value far beyond her advocacy of any theory, and have been widely read and discussed.

THE CRADLE SHIP. Edith Howes Cassell

The author uses nature study to give children their first information about "where the babies come from." The book is charmingly written and illustrated, and will be of service to parents who want to teach their children wisely and in a way which they can understand.

PARENTHOOD AND CHILD NURTURE. Adna Dean Parker.
 McMillan \$3 gold

This book has been prepared by an experienced teacher specially for the use of classes in Parent Training. It takes in the whole life of the child from birth to 12 years of age, and gives good ideas about songs, games, stories, etc. There are references given for further study, including technical books, fiction and poetry, etc. There are also excellent suggestions for thought and discussion which a mother's club would find very worth while.

At the request of the compiler of this list Edward Evans and Sons have ordered the books named and have them in stock, so that they can be obtained without the long wait which an order to a home book-seller necessitates.

PART XI
MISCELLANEOUS
CHAPTER LXXXV

GENERAL YEN AND HIS WORK IN SHANSI

Paul L. Corbin

Shansi Province has the smallest number of soldiers and the largest percentage of children in schools of any of the great provinces of China. These two facts are significant and are not without mutual relation. Together they are an index of the character and work of Governor Yen Hsi-shan.

**Appointment
As Governor**

In the autumn of 1911 chance made Yen Hsi-shan military governor of Shansi, following the revolution. He was not the first, nor the logical, candidate. Propinquity, in time and place, had as much as anything to do with his selection, after the logical candidate had refused. The choice so fortuitously made was a happy one for the people of Shansi. General Yen has held the office of military governor right down to the present time. This in itself constitutes a record. Since 1916 he has been concurrently civil governor. General Yen is a native of Wutai in Shansi, and is now 42 years of age. He is a graduate of a military school formerly conducted in Taiyuanfu, and studied for two years in Japan.

Coming into his important office without previous political experience, the governor took several years to find himself. The last five years cover the period of his real constructive work for the province. Beginning with such a superficial reform as queue-cutting a thorough program of social and political changes has been evolved.

**Method of
Government**

The key to Governor Yen's present method of government in Shansi is to be found in his *yü ts'ai kuan* (育才館). This is the institution

in which the magistrates of the 105 *hsien* (縣) in the province are trained. Its work is under the direct personal supervision of the governor, who attends the sessions of the institution and gives lectures, but is especially concerned that the men shall catch his own vision and be in sympathy with his plans. This produces a type of district magistrate practically unknown elsewhere in China, men who hold office with a view to real public service, rather than with a view to personal enrichment and aggrandizement. While it would be too much to say that the old type of magistrate, venal and avaricious, has been eliminated from Shansi, his days are numbered unless the present administration should be interrupted or overthrown. With this type of district magistrate in office throughout Shansi Governor Yen has been able to carry forward his program with vigor and with great hope of success. The two outstanding features of the program are, first, the suppression of opium using, and second, the promotion of popular education.

Opium

Shansi has long been known as one of the worst provinces of China for the vice of opium smoking. A popular saying ran, "Eleven people out of every ten in Shansi use opium!" Enslaved by this drug, the scions of the great merchant princes of Shansi have allowed their fortunes to be dissipated and their business to pass into the hands of others. Opium has been directly responsible for far-reaching social changes in the last twenty years. The erstwhile aristocrat has been reduced to penury and often to actual beggary. His place in society is being taken by those who were formerly beneath his notice.

The cultivation of the poppy in Shansi was suppressed more than fifteen years ago, under the administration of Governor Ting Pao-ch'üan. Though there have since been sporadic attempts at cultivation, especially in the early days of the republic, to the credit of the officials be it said that these attempts have failed. But at no time in these fifteen years has the growing of opium been prohibited in Shensi (陝西), and of late it has been grown in Honan, in Chihli, and in the special administrative area just to the north of Shansi, Suiyuan. Thus we have the spectacle of Shansi Province, clear of opium-growing, but entirely

surrounded by territory in which the growing is not only not prohibited, but actually encouraged. Under these circumstances the difficulties attendant upon suppression of the traffic in opium in Shansi are enormous. That so great a measure of success has been attained speaks volumes for the courage and probity of Shansi officials. These officials have also had to contend with a well-organized smuggling of derivatives of opium, especially morphia and "*chin tan*" (金丹). Much of this smuggling has been along the line of the Cheng-Tai Railway.

Not only has the traffic in these habit-forming drugs been prohibited: an effort has also been made in each district to cure the victims. The effort has so far been successful that we who have been in touch with this prohibition movement from the beginning have strong hopes of its ultimate triumph, provided Governor Yen's program is not interfered with. In some of the worst districts the vice has already been reduced by ninety per cent.

The second outstanding feature of the governor's program has been his promotion of popular education. Except in mountain districts where the population is too sparse to meet the expense of the new public schools, the old-time school where the pupils learned the classics by heart has practically disappeared. Its place has been taken by the "*kuo min hsüeh hsiao*" (國民學校). Each village is supposed to maintain one or more of these schools for boys and one for girls. A good many villages are now finding it practicable to have boys and girls studying under the same teachers, though with different study and recitation rooms.

Each of the 105 districts (縣) of Shansi is divided into three to five "*ch'ü*" (區), or townships. There is a higher primary school for boys in each district city and, in theory at least, in the head village of each township. In each group of districts corresponding roughly to the old-fashioned prefectures there is a middle school for boys.

Naturally, one of the greatest problems in the development of this educational program has been that of supplying qualified teachers. In the beginning the need was met by holding short-term normal classes in each district. There is now a normal training school in the provincial capital

for the express purpose of preparing teachers for village schools. There are also teachers' colleges there for men and women, for the equipping of teachers for higher primary and middle schools. Their work is supplemented in several other normal schools throughout the province. That this educational program is achieving success is seen by the remarkable growth of higher schools in Taiyuanfu, which has now become one of the most important educational centers in all China.

Foot-Binding A full review of Governor Yen's work for Shansi would require a volume rather than a chapter. Substantial progress has been made in abolishing the practice of foot-binding. Gambling is prohibited and this regulation is vigorously enforced. (Players of "mahjong" in Shansi are liable to arrest and imprisonment.) Real progress has been made in developing village self-government. Sericulture and the cultivation of cotton are being encouraged. The governor's program directly affects every phase of life in Shansi, except, perhaps, the religious. That side of life presents an insistent and compelling challenge to the Church of Christ, and an opportunity without a parallel in Eastern Asia.

CHAPTER LXXXVI

THE SALVATION ARMY

Francis W. Pearce

The Fifth Annual Congress of The Salvation Army Officers, recently held in Peking, provides a convenient occasion for reviewing the progress and work of the Movement during the seven years that have elapsed since operations were commenced in China. This period has been largely occupied in scouting, and in the usual preparatory work. It has been recognized that if the edifice we proposed to build was to endure, the foundations should be well and truly laid. We have good reason to be gratified with the initial progress made, as well as the prospects for the future.

Foreign Officers

The Officers that have come to us from other lands are a striking example of the worldwide growth of the Movement, for our forces have been made up of workers from Britain, America, Canada, Australia, New Zealand, France, Holland, Switzerland, Norway, Sweden and Finland. At present we number a total of 98 Foreign Officers.

Chinese Officers

Our Training Home for Chinese Officers in Peking has done excellent work in preparing our new Cadets for service as Evangelists. Including 29 Cadets in training, we now number 129 Chinese full time workers. These, added to our Foreign Officers, make a total of 227 Officers entirely engaged in the work.

Corps or Posts

Up to the present we have established no fewer than 50 Corps or Posts in the Provinces of Chihli, Shantung and Shansi. In the great majority of these places, meetings, either public or for converts, are held every night in the week (excepting Saturday), and at least two on Sundays.

Irregular Campaigns We have made a special feature of irregular Campaigns. These include frequent Open Air Meetings on market and feast days. Some of these Campaigns within the precincts of Temples on occasions when the people assemble in thousands, have been of a somewhat daring character. Amidst the motley assemblage of showmen and gamblers, buyers and sellers of goods of every kind, our Flag has been raised and people pointed to the Saviour of mankind.

Boat and Cart Expeditions During the past year we have sent out a Boat Expedition to hold meetings in the villages that fringe some of the rivers, and a Chariot Expedition consisting of two Peking Carts, manned by a Foreign and Chinese Officers, to visit and hold meetings in isolated villages. The space allotted me for this article will allow of no more than a condensed summary of the results of these Expeditions during the two months' travelling.

Places visited.....	137
Meetings held (Open Air)	226
Meetings held (Indoor)	56
Gospels sold	24,981

It would be impossible to tabulate other results; eternity alone can reveal the full fruits of seed sowing of this character.

Military Converts During the year we have found it necessary to institute a Special Roll for Military Men who have sought salvation in our various stations, but who are liable to be removed to different places. Only those who give good evidence of sincerity and a desire to persevere are accepted. The Roll already has 127 names, including eight officers.

Social Work Our Social operations have consisted mainly of assistance for Orphan Girls and Boys, and works of mercy in the interest of the very poor during the cold winter months. In several of the larger cities we have opened Chou Ch'angs for the distribution of porridge to thousands of the needy poor. In Peking last winter we ran four such places, and distributed on an average 35,000 meals per week. This winter we purpose to open five places, and, in addition, make some provision for the homeless poor.

including the beggars, to allow them to lie down at night in a warmed shelter. Last winter it was stated in the Press that during 20 days in the month of February the police were called upon to provide 469 coffins for homeless persons frozen to death. We want to prevent the recurrence of such a tragedy if at all possible.

Last winter we sent out five Brigades of men, three times a day, to distribute hot tea amongst the rickshaw men on their stands. In Peking it is stated there are 80,000 licensed rickshaws. It is a work of real mercy to alleviate the hard lot of many of these poor fellows.

Our Girls' Industrial Home in Peking now houses 97 girls. These are being educated and trained to cook and engage in useful home crafts. During the year we have received over 20 new cases of girls who have been rescued before getting into the hands of unprincipled procurers.

Our Boys' Home still remains a small place with but twelve inmates. We hope to extend as funds are available.

The need for some other social enterprises is clamant, and as time goes on we shall undoubtedly be compelled by the force of circumstances to undertake some of them. But in all these works of mercy we shall strive to keep first things first, and make them as far as possible finger posts to Christ, or stepping stones to salvation through Jesus.

CHAPTER LXXXVII

RECENT DEVELOPMENTS AMONG THE CHINESE ABROAD

H. F. MacNair

Until three quarters of a century ago the Chinese were not reckoned among emigrating peoples. In limited numbers they have nevertheless emigrated for permanent residence or travelled for short periods—chiefly for purposes of trade—in the countries bordering on the Chinese empire and in the islands of the Indian and Pacific Oceans for several hundreds of years. Emigration has been mainly from the provinces of Fukien and Kwangtung although considerable numbers have left from Shantung for northern places of settlement and commerce. Numbers of Chinese are now residing in Japan, Siberia, Russia, throughout Malaysia, French Indo-China, the Dutch East Indies, South Africa, New Zealand, Australia, Canada, the United States, Mexico, Central America, the West Indies and several South American as well as European countries. ¹ These people may be generally divided into the following classes: merchants, free laborers, contract laborers, students, diplomatic and consular officers, and travellers.

Number As to the numbers of Chinese residing outside Chinese jurisdiction it was estimated as far back as 1906 that they approximated 8,000,000 or two per cent. of the generally accepted total of the Chinese people. A more conservative estimate is that of Mr. C. K. Chen made in April 1919: "Taking round figures and making allowances for omissions and exaggerations, we may say, the total number of Chinese in the United States and its territories is about 180,000; the number in the British Empire about 1,000,000; the number in Japan and its possessions about 4,000,000; the number in Europe and

1. For further material on this subject see articles published during the past and present year in *The Chinese Social and Political Science Review*, and *The China Weekly Review*.

outlying territories of Continental European nations about 700,000; and in the Central and South American countries about 500,000. The total number of Chinese residing abroad is about 6,380,000. If we take the figure for the total population of China to be 400,000,000 we may conclude that about 1.6 per cent. of the total population have migrated to foreign countries.' But Mr. Chen did not have access to figures for Siam, Burma, Borneo, Sarawak, the French over-sea possessions, or Mexico. When these are taken into account it seems safe to say that there are at least between eight and nine millions abroad. When the facts presented here are remembered it at once becomes clear that it is impossible in a paper such as this to enter into any considerable detail in the discussion of present day conditions among the millions of Chinese who are without the jurisdiction of the government of China. No attempt is made to review the economic, social, or intellectual status of the Chinese in the countries here touched upon. The aim is merely to direct attention to a few outstanding topics of interest which have come up in recent years in reference to the Chinese in a very few parts of the world.

Students

During the past few years there have developed two interesting aspects of the Chinese problem in the United States of America. The one has to do with the students, the other with laborers. The latter may be first considered. From the days of the gold-rush to California, down through the period of exclusion legislation there has never been a time when there have not been considerable numbers of the laboring class who have desired entrance into and residence in the country. To go into the intricacies of the application of the exclusion laws and consider the cases of injustice which have been asserted and protested against by the Chinese would be quite impossible; suffice it to say that during the past few years the Chinese have not ceased attempting to enter America by both legal and illegal means. There are apparently three routes by which Chinese are smuggled into the United States at present by "immigration bootleggers". These routes known to "bootleggers" as "selling points" are via Canada, via Mexico, via Cuba; the last-named being the most important. Secretary of Labor James J. Davis was

quoted a few months ago as saying: "Thirty thousand Chinese are waiting in Cuba to-day watching for a chance to be smuggled into the United States. They are willing to pay \$2,500 a head to one who will accommodate them." An account reprinted in the *Peking and Tientsin Times* of July 31, 1923, from the *New York Times* gives in some detail a description of the smuggling of Chinese, from various sources into the country. Mention is made, for example, of a two-masted Schooner, which was found just outside Quarantine, with fifteen Chinese aboard who were attempting to enter without the necessary papers. "The schooner had no clearance papers; but through an interpreter the Chinese were able to make harbor officials understand that they had obtained passage for the States in the sailing vessel for a consideration of \$500 each." Secretary Davis mentioned also a case, in which twenty Chinese were landed by "bootleggers", on an island off the west coast of Florida. These had paid from \$100 to \$300 a piece. According to the Secretary there is an "Underground Railway" conducted along the Mexican border, for the purpose of aiding Chinese to cross from Mexico, to the United States. Certain ranches are used as "Stations"; thus a system not unlike that, which played such an important part in connection with Negro slavery before the Civil War has grown up nowadays for different, and somewhat dissimilar purposes.

In connection with the Mexican aspect of this problem it may be mentioned in passing that according to the Census of 1910 there were reported to be about 13,200 Chinese in Mexico. Later figures report the presence of 9,000 Chinese in Lower California alone. The number in this section of the country has led to action being taken by the labor element in Sonora and Lower California. In the latter state in June 1922 it was reported that workers were requesting the Government to expel the Chinese and to prohibit future immigration. The Mexicans are apparently enthusiastic in their aid of Chinese who are trying to cross into the United States¹. Returning to the subject of the

1. The most recent reference to Chinese in Mexico coming to the notice of the writer is a report in the *North China Daily News* for Jan. 21, 1924, of several houses of Chinese being shelled in Varadero by rebel gunboats.

latter country — a good deal of smuggling goes on from Canada into the United States in ways somewhat similar to those just mentioned. Although the American government has inspectors and other officers who catch and turn back numbers of Chinese at points where the main highways converge it is nevertheless a fact that many elude the watchers and enter. The field staff of the American Immigration Service numbers but eighteen hundred of whom more than a fourth are stationed at Ellis Island. These are not sufficient to prevent smuggling. Not as many Chinese attempt entrance from Canada as from Cuba for the reason apparently that it is considerably easier to enter Cuba than it is to enter Canada, furthermore it is easier to enter from Cuba than from western Canada. "Probably not over 5,000 Chinese," says Secretary Davis, "are awaiting a chance to be smuggled across the line in that territory."

**Student Treaty
Rights**

In 1920 the Chinese-American Association in Peking, in order to make it easier for Chinese students to get practical experience and at the same time earn a part of the funds necessary for their maintenance while studying in America, petitioned the Department of State for a ruling which would aid *bona fide* Chinese students. Suitable safeguards were offered. The Department of Labor had almost impossible rules for such cases. On February 27, 1922, Attorney-General Daugherty sent to the Secretary of Labor an interpretation of the treaty rights of Chinese students based on a long succession of cases. His conclusion was as follows: "The true rule deducible from the adjudicated cases may be stated as follows, viz., that labor is not necessarily incompatible with the pursuit of an exempt status, and that where the evidence established that the dominant purpose of the Chinese person in coming to this country was to follow one of the exempt avocations, performance of labor as an incident thereto e.g. as a means of providing funds to enable him to maintain his student status would not render his entry invalid or subject him to subsequent deportation. . . . I therefore have the honor to advise you that where the labor performed is only in connection with or in furtherance of the maintenance of the status of student

there is no provision of law for the exclusion or deportation of such Chinese person." The *Peking and Tientsin Times* on August 29, 1923, published a note on the current development of this matter: The Industrial Student plan of placing Chinese students in American industrial establishments for practical training, which was temporarily abandoned, is again to be vigorously pushed.

"New impetus was given the movement by the assurance of the Attorney-General of the United States and officials of the Department of Immigration that Chinese students who were receiving practical training would not be molested as long as they were *bona fide* students.

On the subject of the Chinese in America it is worth while to note the attempts being made by the China Club of Seattle to bring about an amelioration of conditions among the Chinese in the United States especially those entering American seaports. The condition of the Chinese other than the privileged class who enter by sea leaves much to be desired and has caused a great amount of criticism which is entirely justified.

During the year 1923 the Museum Association of Newark spent much time and energy in gathering materials for an exhibition of "China and the Chinese, the Land and the People." Many individuals and institutions in China were solicited for contribution of materials of interest in such an exhibit. The exhibition was opened during the past autumn; the plan is to show the material in different parts of the United States after the exhibit closes in Newark.

No better picture in brief can be given of the Chinese in the United States than that recently drawn by Dr. Fong F. Sec of Shanghai in a review of Mr. J. S. Tow's "The Real Chinese in America"³. Dr. Fong says in part: "On my return to the United States in 1922 I was agreeably surprised to find that the Chinese there occupied a much better position commercially, financially, educationally, and socially than when I left for China sixteen years previously. In place of pronounced racial prejudice, the Americans

3. The Academy Press, New York, pp. 168.

have come to know them better and there was mutual good will and respect. In Seattle and Portland I found Chinese owning business buildings and modern homes in the residential districts. In Sacramento they had branched out into new lines of activity, and I visited a splendid market, which handled meats, poultry, fruits, and vegetables, owned and conducted by Chinese. San Francisco's Chinatown, notorious, in the early days, for its squalor and opium dens, had given place to wider streets and clean-looking up-to-date buildings, some of which, with their pagodas and turned-up corners, have an Oriental effect. Modern banks, export and import firms, shipping and trading companies were among some of the new enterprises. The art goods, antique, jewellery, and sundry stores looked more prosperous than formerly, though, due to the rigid exclusion laws, the Chinese population was steadily decreasing. The Chinese schools and churches were housed in better buildings. I stayed in a six-story hotel that was up to the minute in equipment and appointment, with an elaborately decorated tea garden on the roof, which commands a magnificent view of the bay. Down in Los Angeles and other Pacific Coast cities I found Chinese families, living away from China town, and their children going in for higher education."

**Chinese in
Canada**

In Canada the conditions which led to the immigration of Chinese were not unlike those which prevailed in the United States: gold-mining and railroad-building drew numbers of them in the seventh decade of the nineteenth century. At first immigration into the Dominion, like that into the United States, was free and without restriction. In 1886, however, a tax of \$50 a Chinese head was laid, and other measures of restriction were carried out. Despite these conditions there were by 1901 almost 17,000 Chinese in Canada; accordingly on January 1 of that year the tax was increased to \$100 a head. And on January 1, 1904, it was again raised to \$500 (£ 100) a head. During the three and half years between June 1900 and the beginning of 1904 more than 16,000 Chinese entered Canada by paying the \$100 head-tax. The effect of the \$500 tax was during the first four years to discourage immigration; then suddenly in

1908 and continuing down to 1916 large numbers of Chinese began to enter by paying the tax, high though it was. The explanation of this seems to have been that the practical prohibition of Chinese immigration created a type of labor monopoly for those Chinese who were or who could get in to the country.

These facts may be taken as explanatory and introductory to those which follow. It is reported that at present there are close to 60,000 Chinese in the Dominion of Canada, a majority of whom are in the western provinces, particularly in British Columbia. In the lumber mills, in the fisheries, in agriculture, and in small retail shops large numbers of Chinese are employed.

In the spring of 1923 a Bill limiting Chinese immigration to merchants and students only was introduced into the Dominion Parliament by Minister for the Interior Stewart. As late as March 1924 this bill had not passed the Senate though the Lower House had passed it with some modifications. This proposed measure of the Canadian Government reminds one strongly of the Chinese Exclusion law in force in the United States by reason of certain provisions and general strictness. Great powers are concentrated in the person of the Controller; provision is made for the appointment in countries other than Canada "for the purpose of endorsing passports or performing other duties under this Act;" the £ 100 head tax is repealed; careful arrangements are made for the identification and registration of Chinese immigrants, and provisions are made for the admission of Chinese students and merchants. Diplomatic and Consular officials are, of course, not affected by the new law.

In addition to this proposed immigration measure there has more recently been placed before the British Columbia Legislature a Bill which, if passed, would make it a criminal offence for white girls or Indians to be employed by Chinese in restaurants owned or operated by them. Whether this measure has been passed is not known at the time of writing. The Chinese Consul in British Columbia, Mr. Li Pao-heng has addressed to the Speaker of the British Columbia Legislature a strong protest against this measure on the plea that it is not warranted and constitutes unfair

racial discrimination. It is quite doubtful whether this measure would be upheld by the Courts even if passed.

It is scarcely necessary to remark that the immigration measure discussed above has received bitter criticism as well. In the May 1923 (vol. 4, No. 5) issue of the *China Review* (New York) the editor devoted more than a page to the subject of the proposed measure. A Reuter's telegram was published in the *North China Daily News* of December 9, 1923, headed Peking, December 4: "The Government has received a petition from Chinese residents in Canada protesting against the new Canadian law which, they allege, operates harshly against them, and requesting the Government to take action to have their positions improved." It is unlikely however that China in its present confused state can do anything in reference to this matter.

Chinese in Japan

By far the most talked of incident in reference to Chinese residing abroad during the past few months has been the murder of a considerable number of these people who were living in Japan prior to the earthquake of September 1, 1923. Although the relations between China and Japan are of old standing it was not until after the China-Japan War of 1894-1895 that it was estimated that there were as many as 2,500 Chinese in the whole Japanese Empire. By 1918 there were a few more than 12,000 Chinese in the country. In recent years despite the protests of the Japanese laborers small numbers of Chinese laborers have gone to work in Japan. The strict laws of that land preclude any considerable number of Chinese immigrant laborers.¹

A strict police and military censorship has been maintained and only a few facts have come out regarding the murders which occurred immediately after the earthquake, and during the next few days. As long after the affair as December 6—three months—the censorship was still being kept up as is shown by the obliteration of a three-

1. For a discussion of this topic cf. "Chinese Nationals in the Japanese Empire in *The China Weekly Review*, vol. XXIV, No. 6 (April 7, 1923).

column account published in the *Japan Weekly Chronicle* for that date.¹

It has been estimated that from 68 to 200 Chinese — not to mention a number of Koreans reckoned at 1,500 to 2,000— were murdered either in cold blood or as a result of being mistaken for Koreans. Commenting on this subject Mr. Rodney Gilbert wrote at the end of November last: "The common Chinese attitude is a very just one. It is rightly assumed that during such an epoch of hideous nightmare, when all the worst passions of the worst classes in big cities are not only unchecked but stimulated by terror, orgies of crime are an essential part of the picture. However gruesome they may be they have nothing to do with politics and no bearing upon international relations.

"While the Chinese at large seem still to maintain this attitude toward the killing of their fellow countrymen, the officials here (Peking) are apprehensive that Dr. Wang's investigations may bring to light facts which will force China to take a more serious view of the reported outrages. Chinese familiar with Japan who have recently returned agree in affirming that the majority of Chinese killed after the earthquake were not the victims of panic in the big cities but were deliberately killed by Japanese labor organizations in the smaller manufacturing centres where their presence had been for some time resented. It is explained that during the past few years Japanese capitalists have been importing much cheap Chinese labour and that the Japan labor guilds have been sullenly hostile to this competition and therefore seized upon the period of chaos following the earthquake to wipe out competition in the most direct manner possible. If these reports are verified the Chinese Government will naturally have to take them rather seriously."

The Japanese government has expressed formal regret for the unhappy affair but, according to observers in Japan, the Diet, which was expected to register considerable emotion was strangely lacking in interest in the whole matter when

5. Cf. "How Japanese Police Suppressed News of Chinese Murders in The China Weekly Review, vol. XXVII, No. 7 (January, 12, 1924).

it met some months ago. One member of Parliament, however, is said to have received this reply to his inquiries from the Foreign Office. "If the official report published by the Chinese Legation in Tokyo that the Chinese victims of 'vigilantes' total 68 is true, the number may be taken as the outcome of investigations made by the Chinese Legation. Consequently, the Japanese government is not in a position to recognize the report as authentic. The Japanese Government has already communicated a notification to the Chinese Government, expressing a sense of profound regret at the occurrence of this unfortunate incident. With view to learning the truth of the matter, the Japanese Government is still strongly pressing its investigations. The authorities concerned are not yet in a position to declare any opinion whatever with regard to relief-money to be granted to the bereaved families of the victims of 'vigilantes.'"

Early in December 1923, Dr. C. T. Wang who had been relieved temporarily of his duties in connection with the Commission which is to negotiate with the Russian Soviet, left for Japan to make special inquiries on behalf of the Peking Government. He was courteously received by the Japanese Government and made his inquiries. The Japanese Government has announced from time to time certain results of its own inquiries notably the trials which are said to be in progress of certain of those Japanese who were accused of guilt in connection with the murders. Dr. Wang returned to Peking on January 8. On being interviewed by a Reuter's correspondent he said: "Several hundreds of Chinese were murdered during the earthquake. Some were killed by mistake (the 'vigilantes' taking them for Koreans) and others were murdered either intentionally or because of hatred." Thus the matter rests at present. What the outcome will be it is yet too early to say.

Time and space preclude a wider survey at this time of the conditions among the Chinese abroad. A few considerations may be mentioned briefly in conclusion. It becomes quite clear as one studies the facts in reference to the Chinese living in foreign countries that they are an increasingly important factor in the lands in which they reside. From a religious point of view they present a challenge to the Christian people among whom they live, —

a fact to which the Christians in these countries are paying more and more attention. Finally it may be remarked that it has taken the Government of China many, many years to awaken to its responsibility for protection of the persons and interests of its nationals abroad. One effect of the growing spirit of nationality which has been growing noticeably during the era of the Republic is the interest which the people and Government of China are taking in the welfare of their confreres and nationals abroad. It is safe to say that the next quarter of a century will see even greater development than has been noted during the past quarter of a century. And this is as it should be.¹

1. Students interested in the general subject of the Chinese in foreign lands may consult further the writer's "The Chinese Abroad" published by the Commercial Press, 1924.

CHAPTER LXXXVIII

CHRISTIAN WORK AMONG CHINESE SOLDIERS

Liu Fang

General Feng Most people have heard that Gen. Feng Yu-hsiang is deeply interested in Christianity. He was baptized in the Spring of 1913. He studied the Scriptures regularly and devoutly. Since his barracks are nine miles from the Church, it requires more than two hours' ride to attend worship. Yet he attends the early "Devotional Service" every Sabbath and calls for questions about all doubtful points at the end of the service. Sometimes he brings with him his subordinates or friends. He keeps the "Morning Watch" at six. This indicates his devotion. When young, he was a man of very quick temper; but as a result of study of the Bible he has become quite a different man, and now wears a look of love upon his face. He has grown in Christian experience. In Europe, there are chaplains officially attached to the armies, an arrangement unknown in China. General Feng, however, himself supports four men to preach to his troops. Orders in his army are willingly obeyed not because of his severity but because of his Christian personality. Confucius said, "When a prince's personal conduct is correct, his government is effective without the issuing of orders. If his personal conduct is not correct, he may issue orders but they will not be followed". This is certainly true. General Feng observes and executes the troop orders himself as a model for imitation. He instructs his men to be frugal and diligent; he has his own uniforms made of the same material as that of a common soldier. He gets up very early in the morning and works hard from dawn to eve every day. Both his residence and food are of the simplest. Here is the secret which has raised him to his present standing.

General Feng's Troops General Feng often invites both Foreign and Chinese ministers from all parts of China to preach to his troops. This he did even when his troops were stationed in Szechwan and Hunan Provinces. As soon as he was promoted to the Military Governorship of Shensi and Honan Provinces successively, he became more fervent. The Rev. Liu Fang has repeatedly been asked by the General to preach to his men. When he was the Occupation Commissioner in Hunan, the Rev. Liu once preached for ten successive days. On the last day, eighty-nine officers and more than eight hundred soldiers were baptized. Some of these men are now Cabinet Ministers, Vice-ministers, Brigadier-generals, Colonels and important officials in other Government departments.

Service of Song General Feng pays special attention to the service of song. One of his officers, who understood musical notes, was appointed to go to the Rev. Liu's home to learn hymns so as to teach the other officers, who, in turn, taught the soldiers. Hence all the soldiers can sing. They sing not only when worshipping and in religious meetings, but also when going along the streets: thus the people easily recognize them as General Feng's troops.

At meetings, each man brings with him his own Bible and Hymn Book, and many of them take notes of the sermons. They hold regular Prayer Meetings. They offer thanks to God for every meal. As they are spiritually cultured their lives are eminent in comparison with those of other armies. They do not smoke, nor drink, nor gamble. People love them as their own brothers instead of fearing them as vipers.

Soldier Services Since the removal of the army to Nanyuan (near Peking) in the Winter of 1922, there have been regular "Devotional Services" on Sundays. Attendants number as many as thirty thousand. The Rev. Liu Fang was once asked to invite ten preachers to go from Peking Churches to Nanyuan, every Sabbath, to preach at ten different places at the same time.

February 10-15, 1923, there was a "Special Evangelistic Meeting". The Rev. Liu Fang was requested to invite all the preachers of the Peking Methodist Churches,

the faculties of Peking Academy and of Peking University; and one choir, totalling altogether fifty two persons, to conduct Preaching and Prayer Meetings and Bible classes. The preachers were all filled with the Holy Spirit and preached the Gospel earnestly and effectively. The hearts of the audience were deeply moved. The work of baptizing the converts alone occupied the whole of the last day; namely, the 15th of February. Those officers and cadets that accepted the Christian faith that day numbered as many as thirty seven hundred and ninteen. As there is no building in the encampment large enough to accomodate such a large body of men, the baptismal ceremony was held on the drill ground. The converts were divided up into squads. Each squad contained fifty men, who were baptized individually by eight pastors, whose arms fairly ached before the ceremony was over. In the History of the Christian Church, I dare to say, that this was probably the first time that so many men adopted Christianity simultaneously. Even in the day of Pentecost, only about three thousand souls were baptized. Therefore, this day and and these facts are worthy of remembrance.

On the tenth of February, 1923, eleven hundred of General Feng's soldiers were baptized on the drill ground at Tungchow, the east suburb of Peking. Eight pastors aided the Rev. Liu Fang in the ceremony. They were Dr. George Davis, Dr. Carl Felt, Rev. Hsu Kun Shan and others.

On Christmas Day and Easter Sunday, General Feng is accustomed to order all his men to be at the drill ground to hold mass meetings.

Attendance at Communion General Feng is deeply interested in the Communion and desires to give every Christian in his army a chance to take it. As he has more than ten thousand Christians under his command, it is impossible for all of them to partake of the Communion at one time and in one place. So they are divided into groups. Each group has five hundred men, and the groups attend the "Communion Service" by turns, one group a Sunday. This plan enables them all to receive the Communion easily.

As to the officers, four special "Communion Services" are administered annually. At each of the services, over eight hundred officers take the Communion. They also hold "Summer Retreat Conferences" to which General Feng is accustomed to invite both Foreign and Chinese Christian Leaders.

CHAPTER LXXXIX

“SOME SPECIAL LAWS PERTAINING TO CHINESE WOMEN”

Chu Feng-ch'ih

Since the beginning of the Republic, strife has continued incessantly, and the weapons of war have been everywhere. Parliamentarians have forgotten their duties with regard to what appertains to government, so much so that the very root of law and order of the country — the Constitution — has not yet been fixed; so it is not to be wondered at that other laws are not yet completed. What are used at present are mostly what have been handed down from the laws of the Manchu regime. The Supreme Court gathers from the laws of all countries and adapts them to requirements; so it is difficult to speak with certainty about the laws.

Our country has differentiated between men and women, and the laws have followed custom, and have not always been reformed to meet new standards. A woman has been under the control of the heads of her family, or of her husband, and her rights have been almost entirely taken away; in reality she has not always been treated equitably. At the present time civilization is daily progressing, and the rights of women are gradually being developed.

Property 1. Joint Property.
By the customary practice in China, a woman has no independent property of her own; in law the property of a husband and wife is considered as joint; but a woman has not the right to dispose of any part of joint property. If she wishes to dispose of any, she must first obtain her husband's consent, to be in accordance with law.

(2) Private Property. This may be divided into two kinds: (a) the bridal dowry; (b) presents. The dowry given by her parents to a woman on marriage, as well as the presents given by relatives and friends, these are the

woman's private property, and she has full power to dispose of them.

It should therefore be noted with regard to property, that it cannot be said that a woman has no power of disposal, only there are limitations to her powers as above stated.

Marriage (1) Betrothal.
 (a) The parents should manage the affairs relating to marriage, or if no parents are available, then the elder relatives have the power to act.

(b) Betrothals should be arranged by "go-betweens" and the two clans and family elders should agree.

(c) The "Keng t'ieh" — paper setting forth the 'eight characters' — of the contracting parties should be mutually exchanged.

(d) There is no fixed amount of betrothal money, much or little; this should be arranged by consultation of the two families according to wealth and position.

In some backward places there may be other conditions fixed, but the Law looks upon these as bad customs.

(2) Marriage, (completion of)

In addition to the conditions of the betrothal papers, a fixed ceremony should be gone through. According to the old style there is what is called "pai t'ang," and in the new style is the "enlightened" or "foreign-style" ceremony; these are both according to law.

There is also the present so-called "free marriage;" although the law takes the attitude of non-interference in such cases, yet if they come into court, they cannot stand as lawful. **YOUNG WOMEN MUST BE VERY CAREFUL ABOUT SUCH ALLIANCES.**

Divorce In the early days of the Republic, divorce was very prevalent, and Shanghai, being a great port, was worse than other places. Those who make the laws saw that those deficient in morality indulged in malpractices and took the opportunity to do evil, so that it was necessary to have some severe regulations fixed. Divorce can now be obtained for the reasons set forth below only.

According to the Provisional Civil Code, Article 1362, either husband or wife may institute divorce proceedings, but only for the following reasons : —

1. Bigamy.
2. Adultery on the part of the wife.
3. The husband having been punished for adultery.
4. If either party intentionally plans to kill the other.
5. If either party is so cruelly treated by the other as to make it unfit for them to live together, or if one suffers excessive insult and shame.
6. If the wife ill-treats the husband's elders, or family, or puts them to great insult or shame.
7. If the wife suffers ill-treatment or great insult or shame from the husband's elders and family.
8. If either husband or wife, with evil intent, leaves the other.
9. If either husband or wife is not heard of for over three years, so that it is not clear whether one is living or not.

It was necessary to prepare these strict laws to prevent the springing up of disorders.

Succession Our country has always regarded the family as important and looks upon blood succession as still more important. Therefore in regard to the matter of succession, the law steps in. If an heir is not of the same blood as the one he inherits from, he cannot carry on the succession, for the near and distant must not be confused. But the validity of an heir is the same as that of a son (whether of the first wife or of any other wife). A widow who remains unmarried, with regard to succession, has complete power to set up her successor ; but if the son adopted is not of the closest relationship to the deceased husband, the official should be informed that someone else has been adopted. This special right of women with regard to the law, is because China has always highly regarded the steadfast purpose of a widow who will not remarry, so the lawmakers in this way showed special respect to such women.

In law, the original intention is not to permit heirs having different family names, leading to confusion of families and ancestry. An adopted son cannot be recognised as an heir in succession; although one has an adopted son, yet he should make someone else his heir; but in the division of property and possessions, it is allowed by law to make fair adjustments.

PART XII

OBITUARIES — 1922-23.

- Ahs, Rev. Johan, S. M. F., arrived in China 1912, died June 2, 1923, at Shasi, Hupeh.
- Arpiainen, Miss J. M., F. F. C. (CIM), arrived in China 1893, died February 16, 1922, at Yungfenghsien, Ki.
- Armstrong, Geo. A., E. P. M., arrived in China 1902, died October 5, 1922, at Kewanee, Ill., U. S. A. (See sketch Chinese Recorder, February, 1923).
- Baller, Frederick William, C. I. M., arrived in China 1873, Life Governor of the British & Foreign Bible Society, died August 12, 1922, at Shanghai, China. (See sketch Chinese Recorder, November, 1922).
- Blough, Miss Anna V., G. B. B., arrived in China 1913, died May 9, 1922, at Pingting, She. (See sketch Chinese Recorder, August, 1922).
- Borjesson, Miss Hilma, S. M. F., arrived in China 1893, died November 5, 1923, at Kuling, Ki.
- Couling, Rev. Samuel, M. A., B. M. S., compiled the "Encyclopædia Sinica," died June 15, 1922, in Shanghai, China. (See sketch Chinese Recorder, July, 1922).
- Distad, Dr. O. E., L. U. M., arrived in China 1919, in charge of hospital at Sinyang, Ho., died June 12, 1922, at Sinyang.
- Dring, Miss Grace, C. I. M., arrived in China 1900, died June 4, 1922, at Kuling, Ki.
- Eaton, Miss Delta F., M. E. M., arrived in China 1921, died Dec. 10, 1923, at Chengtu.
- Ellison, Rev. E. J., B. Sc., B. M. S., arrived in China 1908, died September 3, 1923 at Kuling, Ki.
- Elwin, Rev. A., C. M. S., arrived in China 1807, died May 1st, 1922, in London, England. (See sketch Chinese Recorder, August, 1922).
- Evans, Edward, arrived in China 1889, organizer of "Missionary Home and Agency," died September 21, 1923, on Mokanshan. (See sketch Chinese Recorder, November, 1923).

- Ferguson, Rev. Duncan, M. A., E. P. M., Tainan, Formosa, died in the 63rd year of his age at Eastbourne, England.
- Fitch, Rev. George F., D.D., P.N., arrived in China, 1870, Superintendent Presbyterian Mission Press, Editor Chinese Recorder, died February 17th, 1923 at Shanghai, China. (See sketch Chinese Recorder, April, 1923).
- Forsyth, Robert Coventry, B. M. S., arrived in China 1884, died December 31, 1922, at Tsinan, Sung. (See sketch Chinese Recorder, May, 1922).
- Grinell, Dr. A. L., F. M. A., arrived in China 1912, died November 18, 1923, on his 43rd birthday at Kaifeng, Ho.
- Hagquist, Mrs. W., S. A. M. (CIM), arrived in China 1892, died January 22, 1922, at Sianfu, She.
- Hunt, Mrs. Edward, C. I. M., arrived in China 1890, died December 26, 1922, at Wenchow, Che. (See sketch Chinese Recorder, February, 1922).
- Keen, Charles Scull, Ph. B., M. A., A. B. F. M. S., arrived in China 1902, Dean of the Department of Missionary Training of the University of Nanking, died May 20, 1923, in Nanking. (See sketch Chinese Recorder, July, 1923).
- Lawson, Edmund Fallows, M. B., C. M. S., arrived in China 1912, served in the R. A. M. C., died June 11, 1922, at Foochow, Fu. (See sketch Chinese Recorder, August, 1922).
- Lewis, Mrs. G. W., A. B. C. M. S., arrived in China 1905, died October 25, 1922, at Redlands, California. (See sketch Chinese Recorder, January, 1922).
- Lindvall, Miss D., S. A. M. (CIM), arrived in China 1891, died February 12, 1922, at Sianfu, She.
- Mackenzie, Mrs. Murdock, P. C. C., arrived in China 1889, died 1922 at Montreal, Canada. (See sketch Chinese Recorder, May, 1922).
- Mackenzie, Dr. Marcus, C. M. S., arrived in China 1897, served in the R. A. M. C. from 1916, till 1919, died June 18, 1922, at Foochow, Fu. (See sketch Chinese Recorder, August, 1922).
- Matson, Mrs. P., S. E. M. C., arrived in China 1891, died December 29, 1922, at Siangyang, Hup.
- Myers, Rev. Henry Van Schoonhoven, S. T. D., born May 27, 1842, in New York City, arrived in China 1903,

- died June 12, 1923, at Peitaiho. With the American Bible Society five years.
- Nelson, Mr. J. G., S. A. M., arrived in China 1891, died November 28, 1922, at Lungchow, She. (See sketch Chinese Recorder, February, 1922).
- Nilssen, Jorgen Edvin, M. A., M. D., N. M. S., arrived in China 1902, General Secretary of the N. M. S., died October 28, 1922, at Stavanger, Norway. (See sketch Chinese Recorder, February, 1923).
- Nordlund, Mrs. V. L., S. E. M. C., arrived in China in 1891, died September 8, 1922. (See sketch Chinese Recorder, October, 1923).
- Parrott, A. G., M. R. C. S., L. R. C. P., C. I. M., arrived in China 1878, Honorary Medical Officer to the Door of Hope Mission, Foreign Women's Home, Blind School for Chinese boys and the Chinese Industrial School, died May 22, 1923, at Shanghai, China. (See sketch Chinese Recorder, July, 1923).
- Pierce, Rev. L. W., S. B. C., arrived in China 1891, drowned July 16, 1922, at Soochow, Ku. (See sketch Chinese Recorder, December, 1922).
- Reifsnnyder, Dr. Elizabeth, W. U., arrived in China 1883, first missionary sent out by that Society and started first hospital for exclusive treatment of women and children. Died at Liverpool, Penn., U. S. A. (See sketch Chinese Recorder, May, 1922).
- Schrack, Miss Bertha, S. C. M., Paoning, Sze., arrived in China 1901, died March 8, 1922, at Fu-yin tsun, Tamingfu, Chi.
- Scorer, Miss H. M., C. I. M., arrived in China 1904, died February 14, 1922, at Paoning, Sze.
- Scott, Deaconess Katherine E., A. C. M., arrived in China 1911, Head-Mistress of St. Hilda's School for Girls, Wuchang, died on August 26th, 1923, at Peking, China. (See sketch Chinese Recorder, November, 1923).
- Sears, D. D., Rev. William H., S. B. C., arrived in China, 1892, died August 5th, 1922, at Tsingtao. (See sketch Chinese Recorder, July, 1923).
- Soderbom, Mrs. Carl G., M. P., arrived in China 1894, died April 23, 1922, at Kalgan, Chi. (See sketch Chinese Recorder, January, 1922).

- Stunt, Mrs. R. W., C. M. M. L., arrived in China 1906, died May 18, 1923, at Hada, Jehol Territory.
- Trickey, Mrs. E. G. W., C. I. M., arrived in China 1917, died April 16, 1922, at Kaifeng, Ho.
- Warner, Rev. Frank Bradford, A. B. C. F. M., arrived in China 1914, died June 15, 1923, at Oberlin, Ohio, U. S. A.
- Webster, Rev. James, U. F. C. S., from 1910 Foreign Mission Secretary in Edinburgh, died at Home, 1923. (See sketch Chinese Recorder, July, 1923).
- Wennborg, Mrs. Stina, S. M. F., arrived in China 1907, died May 31, 1922, at Kingchow, Hup.
- Wheeler, Miss M. M., M. C. C., arrived in China 1915, died November 15, 1923, at Chengtu, Sze.
- Wilson, J. Ward, C. M. M. L., arrived in China 1891, died September 16, 1923, at Wellington, New Zealand.
- Wright, Rev. Harrison King, P. N., arrived in China 1902, died on July 24th, 1923, at Shanghai. Member of staff of C. L. S.
- Young, Miss F. A. M., C. I. M., arrived in China 1899, died June 17, 1922, at Wenchow.
- Young, Dr. Andrew, B. M. S., arrived in China 1905, died 1922, at Tsinanfu, Sung. (See sketch Chinese Recorder, August, 1922).

PART XIII
APPENDICES
BIBLIOGRAPHY

FRANK RAWLINSON, EDITOR, CHINESE RECORDER

I. BOOKS AND PAMPHLETS

January to December, 1923.

1. For Reference

- | | |
|--|--|
| <p><i>China Mission Year Book—1923.</i>—
Edited by Frank Rawlinson.
Christian Literature Society,
Shanghai. Mex. \$2.00.</p> <p><i>China Year Book, The</i>—Tientsin</p> | <p>Press Ltd., Tientsin. Mex.
\$12.00.</p> <p><i>Directory of Protestant Missions
in China, 1923.</i>—Kwang Hsieh
Publishing House. Mex. \$2.30.</p> |
|--|--|

2. Romance and Art

- | | |
|---|---|
| <p><i>Chinese Drama, The</i>—by R. F.
Johnston, C. B. E., M. A.
Kelly & Walsh, Ltd., Shang-
hai.</p> <p><i>Chinese Nights Entertainments</i>—
by Brian Brown. Brentano's,
Fifth Avenue, New York.</p> | <p><i>Dogs of China and Japan in
Nature and Art</i>—by V. W. F.
Collier. William Heinemann,
London.</p> <p><i>Work of Li Po, The Chinese Poet,
The</i>—by Shigeyoshi Obata. E.
P. Dutton & Co., New York.</p> |
|---|---|

3. Travel

- | | |
|--|---|
| <p><i>In and Around Yunnan Fu</i>—by
Gabrielle M. Vassal. William
Heinemann, London. 10/6 net.</p> | <p><i>Travels of a Consular Officer in
Eastern Tibet</i>—by Eric Teich-
man. University Press, Cam-
bridge. 25/- net.</p> |
|--|---|

4. Language

- Five Hundred Proverbs Commonly used in West China*—by Capt. A. J. Brace, F. R. G. S. Canadian Mission Press. Mex. \$0.50.
- Supplement to Dictionary of the Vernacular or Spoken Language of Amoy*—by Rev. Thomas Barclay, M. A., D. D. Glasgow. The Commercial Press, Ltd., Shanghai. Mex. \$10.00.

5. Research

- Chinese Literature, Notes on*,—by A. Wylie. Presbyterian Mission Press. Mex. \$7.00.
- Chu Hsi and His Masters*—by J.P. Bruce. Probsthain & Co., 41 Great Russell Street, British Museum, London, W. C. I. 24/-
- Logical Method in Ancient China, The Development of the*—by Hu Shih (Shih Hu). The Oriental Book Co., Shanghai. Mex. \$1.20.
- Me Ti, Des Socialthikes und Seiner Schuler Philosophische Werke*—by Dr. Alfred Forke. Kommissionsverlag der Vereinigung Wissenschaftlicher Verleger, Berlin. M. 20,000. 0.8.6. G. \$2.60.
- Nestorian Adventure in China, My*.—by Frits Holm. Fleming H. Revell Co., New York. Mex. \$7.70.
- Philosophy of Human Nature*—by Chu Hsi. Probsthain & Co, 41 Great Russel St., London, W. E. 36/- net.
- Tankare I Det Gamla Kind*—by Erik Folke. Birkagårdens, Förlag, Stockhol.

6. Religion

- Chinese Superstitions, Researches into Vol. VII.*—by Henry Dore, S.J. Fouseweil Press, Shanghai. Mex. \$4.50.
- Fra Ostens Religiose* LIV.—by Karl Ludvig Reichelt. G.E.C. Gade Forlag, Köbenhavn, 1922.
- Kinas Religioner*—by Karl Ludvig Reichelt. Det Norske Missionssselskaps Forlag, Stavanger, 1922.

7. China Within

- American University Club in China*—(Papers) George E. Sokolsky. Commercial Press, Ltd., Shanghai.
- Charm of the Middle Kingdom, The*—by James Reid Marsh. Little, Brown & Co., Boston G. \$3.00.
- Beyond Shanghai*—by Harold Speakman. The Abingdon Press G. \$2.50.
- China in the Family of Nations*—by Henry T. Hodgkin, M.A., M.B. George Allen & Unwin, London. 7/6 net.

- China To-day Through Chinese Eyes*—Student Christian Movement. 32 Russell Square, London, W.C.1. 2/6 net.
- China's Crossroads*—by Elliott I. Osgood, M. D. Powess & White, Cincinnati, Ohio.
- Chinese Screen, On a*—by W. Somerset Maughn. William Heinemann Ltd. 10/6.
- Economics for China, Readings in*—by C.F. Reiner. Commercial Press Ltd., Shanghai. Mex. \$5.00.
- History, Economics & Public Law, Studies in*—Chuan Shih-Li, Ph. D. Columbia University, New York.
- Linguist 1923, the Annual*—Nanking Language School.
- Peking Mandarin, the Annual*—North China Union Language School.
- Studier Och Bilder Fran Det Nya Kina*—by Ingeborg Wikander Sveriges Kristliga Studentrörelses Förlag, Stockholm.
- Swinging Lanterns*—by Elizabeth Crump Enders. D. Appleton & Co., New York. G. \$2.50.
- Tai Race, the*—by William Clifton Dodd. The Torch Press, Cedar Rapids, Iowa.
- Twin Travellers in China and Japan*—by Mary H. Wade. Fred. A. Stokes Co., New York. G. \$1.75.

8. Education

- Christian Education and the National Consciousness of China.*—by James B. Webster. E. P. Dutton & Co., New York. G. \$2.50.
- Education and Chinese Agriculture*—by Kenyon L. Butterfield, A. M. LL.D. The China Christian Educational Association, Shanghai. Mex. \$0.30.

9. International Relationships

- Americans in Eastern Asia*—by Tyler Dennett. Macmillan, New York. G. \$5.00.
- China in American School Text Books*—by T. T. Lew. Chinese Social and Political Science Association, Peking. Mex. \$1.25.
- Extraterritoriality Problem, The*—by Jean Escarra. La Librairie Francaise, Peking. Mex. \$0.60.
- Histoire General de la Chine et de Ses Relations Avec Les Pays Etrangers Depuis Les Temps Les Plus Anciens Jusqua la Chute de la Dynastie Mandchou.*—par Henri Cordier, Librairie Paul Geuthner
- Indiscreet Chronicle from the Pacific, An*—by Putnam Weale. Dodd, Mead & Co., New York. Mex. \$6.00.
- International Development of China, The*—by Sun Yat-sen. G. P. Putnam's Sons, New York.
- Modern Chinese History*—by Harley Farnsworth MacNair, Commercial Press, Ltd., Shanghai.
- Open Door in Relation to China, The*—by Mingchien Joshua Bau, Ph.D. The Macmillan Co., 1923, New York.

10. The Christian Movement

- Flood-Tide in China*—by B. B. Chapman, M. A. Wesleyan Missionary Society, 24 Bishopsgate, London, E. C. 1/-

II. ARTICLES

(July 1, 1922 to June 30, 1923)

- | | |
|---|--|
| C. C.=Christian Century | I. R. M.=International Review of Missions. |
| C. J. S. A.=China Journal of Science and Arts. | J. R.=Journal of Religion. |
| C. M.=China's Millions. | L. A.=Living Age. |
| C. M. J.=China Medical Journal. | M. R. W.=Missionary Review of the World. |
| C. R.=Chinese Recorder. | N. C. R.=New China Review. |
| C. S. P. S. R.=Chinese Social and Political Science Review. | T. D.=Trans-Pacific. |
| E. R.=Educational Review. | W. R.=Weekly Review. |
| F. E. R.=Far Eastern Review. | |

1. Romance and Art

- | | |
|--|--|
| <i>Chinese Idea of a Garden, The</i> —Florence Ayscough. C. J., Page 15, Jan., 1923. | <i>Art of Textile Work, The</i> —Ingeborg Wikander. C. R., Oct., 1922. |
| <i>Poetry of China, The</i> —Soong Tsung Faung. L. A., Page 662, June 10, 1922. | <i>Social Message in Chinese Poetry, The</i> —Hu Shih, (Hu Suh) Ph.D. C. S. P. S. R., Page 66, Jan., 1923. |
| <i>Preservation of the Old Chinese</i> | |

2. Travel

- | | |
|--|--|
| <i>Tibet, the Stupendous</i> —Sven Hed-in. Asia, Page 725, Oct., 1923. | <i>Yen Tang</i> —Robert F. Fitch. C. R., Dec., 1923. |
|--|--|

3. Research

- | | |
|---|---|
| <i>Ancient Chinese Philosophy</i> —R. F. Johnston. C. S. P. S. R., Page 142, April 1923, No. 2. | <i>Basic Philosophy of Confucius and Its Later Development, The</i> —R. Y. Lo. C. R., Jan., 1923. |
|---|---|

- Brief Account of the Early Development of Sinology, A*—Prof. A. H. Rowbotham. C. S. P. S. R., Page 113, April 1923.
- Chinese Hospitals in Ancient Times*—K. C. Wong. C. M. J., Page 77, Jan., 1923.
- Clan Customs in Kiangsi Province.*—Fred R. Brown. C. R., Aug., 1922.
- Introduction to the "Documents Chinois Decouverts par Aurel Stein dans les Sables de Turkestan Oriental" (Continued)*—Edouard Chavannes. N. C. R., Page 427, Dec., 1922.
- Jesuits at the Capital of China, The First Arrival of the*—A. C. Moule. N. C. R., Page 450, Dec., 1922.
- Liu Hsiang and Ts'ien on Sün-Tsz*—E. H. Parker. N. C. R., Page 443, Dec., 1922.
- Sericulture in Fukien Province, Notes on*—C. R. Kellogg. C. J. S. A., Page 59, Jan., 1923.
- Tarbagan or Siberian Marmot, The*—Wu Lien Teh. C. J. S. A., Page 39, Jan., 1923.
- Yin-Yang Theory, On the Antiquity of the*—Leopold de Saussure. N. C. R., Page 457, Dec., 1922.

4. Religion

- Anti-Religion Movement, The*—N. C. S. Chang, S. H. C. Hu and Y. T. Wu, C. S. P. S. R., Page 103, April, 1923.
- Buddhism in China—A Historical Sketch*—Kenneth J. Saunders. J. R., Page 256-275, May 1923.
- Litholatry in Badi and Bawang, and Some Non-Lamaist Regions*—J. Huston Edgar. C. R., April, 1923.
- Religious Beliefs and Practices of the Common People of China, Study of the*—Albert George Parker. C. R., August 1922, Part 2, Sept., 1922.
- Religious Problems as Viewed by Chinese Thinkers*—Lee Hsi Dzen. C. R., Aug., 1922.
- Right to Call the Supreme Being "Shangti"? Is it*—Ti Shan Kough. C. R., Nov., 1922, Part 2, Dec., 1922.
- Superstitions Common in Kiangsi Province*—Fred. R. Brown. N. C. R., Page 493, Dec., 1922.
- Tai Hsü and Modern Buddhism*—Frank R. Millican. C. R., June, 1923.
- Tao Yuan, The*—F. S. Drake. C. R., Mar., 1923.

5. China Within

- Application of the Federal System of Government to China*—Dr. S. Gale Lowrie. C. S. P. S. R., Page 56, Jan., 1923.
- Banditry, Bankruptcy or Boxers?* Charles A. Dailey. W. R., Page 291, Jan. 20, 1923.
- Banditry in China, The Real Significance of*—Charles A. Dailey. W. R., Page 207, Jan. 6, 1923.
- Banditry Focuses Eyes of World on China.* W. R., Page 372, May 12, 1923.

- Bandits, "Esteemed Guests" of the Chinese*—J. B. Powell. Asia, Page 84, Nov., 1923.
- Bandits, "Golden Eggs" Depart, The*—J. B. Powell. Asia, Page 914, Dec., 1923.
- Cabinet Government in China a Failure—Why?* J. J. Heeren, Ph.D. W. R., Page 240, Jan. 13, 1923.
- Camping with Shantung Bandits*—J. B. Powell. W. R., Page 447, May 26, 1923.
- Canton's Experiment with Commission Government*—S. Y. Wu. W. R., Page 44, Dec., 9, 1922.
- Cantonese and the Kuomintang*—Hing Wong. W. R., Page 382, Feb. 3, 1923.
- Central China Fears Foreign Intervention*—Peter S. Jowe. W. R., Page 14, Dec., 2, 1923.
- Changes in the Christian Literature World in Twenty-one Years, 1900-1921.* D. McGillivray. C. R., Aug., 1922.
- Chaotic Political Condition of China, The*—S. K. Yu. W. R., Page 127, Dec., 23, 1922.
- China's Problems, Dr. W. W. Yen On*—Grover Clark. W. R., Page 410, May 19, 1923.
- Chinese Constitution, Framing and Adoption of the*—Mingchien Joshua Bau. W. R., Page 175, July 7, 1923.
- Chinese Legal System, The*—Leonard S. Hsu. W. R., Page 12, March 3, 1923.
- Chinese Robbers, In the Hands of*—W. H. Oldfield. C. R., Aug., 1922.
- Civil War, China's Annual*—Nathaniel Peffer. Asia, Page 511, July 1922.
- Feast of Cold Food, The*—Lewis Hodous. N. C. R., Page 470, Dec., 1922.
- Foreign Newspapers and China's Progress*—Harold S. Quigley. W. R., Page 170, March 31, 1923.
- Historical and Traditional Data about Nanchang*—Francis Clair Gale. N. C. R., Page 474, Dec., 1922.
- Home Life in China*—Mrs. Guy W. Hamilton. M. R. W., June 1923.
- Lincheng Outrage the Death-knell? Is the*—V. P. Ting. W. R., Page 37, June 9, 1923.
- Mutiny Cases in China Since the Revolution*—Jameson Y. Chang. W. R., Page 501, Feb. 24, 1923.
- New China on The Ways*—J. C. Garritt. M. R. W., Page 22, Jan., 1923.
- Personal Story of Experiences in Hands of Bandits.*—J. B. Powell. W. R., Page 407, May 19, 1923.
- Renaissance in China, The*—C. C., Page 1614, Dec., 28, 1922.
- Szechuan for the Szechuanese*—Roy C. Bennett. W. R., Page 444, Nov., 25, 1922.
- Will the Next Annual Civil War Start in Szechuan?* Roy C. Bennett. W. R., Page 89, Dec., 16, 1922.

6. International Relations

- British Chambers of Commerce and the Boxer Indemnity, The*—C. G. Sparham. C. R., April 1923.
- China's Disruption, Our Concern in*—Upton Close. Asia, Page 473, July 1923.

- Chinese Jurist's Views on Extraterritoriality, A*—Francis Zia. W. R., Page 167, Dec., 30, 1922.
- Congressman Dyer's Indictment of China*.—W. R., Page 377, Feb. 3, 1923.
- Intervention and the Situation in China*—Harold Scott Quigley. W. R., Page 38, June 9, 1923.
- Revision of the Chinese Tariff*—Clarence S. K. Chow. C. S. P. S. R., Page 1, Jan., 1923.

7. Education

- John Dewey's Criticism of China's Mission Colleges*—Guy W. Sarvis. C. C., Page 1449, Nov., 23, 1922.
- Kwangtung Chinese Receive Liberal Education*—S. Kanai. T. P., Page 58, Oct., 1922. B. W. Fleisher Publisher & Editor.
- Modern Education in China*—John C. Ferguson. C. R., Oct., 1, 1922.
- New Chinese School System, The*—Jameson Y. Chang, B.Sc. W. R., Page 164, Mar., 31, 1923.
- New Department in Higher Education*—H. Balme. C. R., June, 1923.
- Three Years' Experiment in Pupil Self Government*—Lowry Davis, M. A. E. R., Page 152, April, 1923.

8. Commerce and Industry

- Agriculture in the Economic Life of the New China*—Julcan Arnold. W. R., June 23, 1923.
- Chinese as Contract Labourers, The*—H. F. MacNair. W. R., Page 449, May 26, 1923.
- Chinese Engineering Development*.—F. E. R., Page 165, Mar., 1923.
- Economic China of To-day—Growth and Future*. M. T. Z. Tyau. T. P., Page 46, Nov., 1922.
- Egg Production in China A Giant Industry*—C. O. Levine. T. P., Page 67, Jan., 1923.

9. Reform

- Reform in China Waits on the Powers*—Charles Dailey. W. R., Page 207, July 14, 1923.
- Working for Social and Culture Regeneration of China*—Ta Chen. W. R., Page 220, July 14, 1923.

10. Finance

- China's Financial Problem Has Close Bearing on Existence of Nation*—Hollington K. Tong. W. R., Page 6, Dec., 2, 1922.
- China Finances Since the Washington Conference*—Jacob Gould Schurman. W. R., Page 13, June 30, 1923.

- China's Future Independence Menaced by Debt Problem*—Hollington K. Tong. W. R., Page 46, Dec., 9, 1922.
- China's Obligations to her Domestic Bankers*—Hollington K. Tong. W. R., Page 90, Dec., 16, 1922.
- China's Serious Financial Situation*—Hollington K. Tong. W. R., Page 439, Nov., 25, 1922.
- Financial Reconstruction of China and the Consolidation of China's Present Indebtedness*.—G. Padoux. W. R., Page 17, June 30, 1923.
- Is China on the Verge of Bankruptcy?*—Dr. C. T. Wang. W. R., Page 5, June 30, 1923.
- Native Banks of Shanghai, The*—T. S. Hsu. W. R., Page 31, June 30, 1923.
- Trading With Foreign Money in China*—Roy C. Bennett. W. R., Page 45, June 30, 1923.

11. Social Problems

- Agriculture in the Economic Life of the New China*—Julean Arnold. W. R., Page 141, June 30, 1923.
- Anti-Opium Association, Pe-king.*
- Blindness in China*—C. M. J., March-April, 1923.
- Funeral Expenses in China*—C. M. J., March-April, 1923.
- Chinese Amended Laws Concerning Morphine*.—C. M. J., Page 184, Feb. 1923.
- Opium*.—H. F. McNair. W. R., June 23, 1923.
- Doping of China, The*—C. R., June 1923.
- Public Opinion as a Force in China*—Frederick W. Stevens. C. S. P. S. R., Page 44, Jan., 1923.
- Drug Cultivation in China*—Prof. B. E. Read. C. M. J., Page 147, Feb., 1923.
- Public Opinion as a Force in China*—Frederick W. Stevens. W. R., Page 157, March 31, 1923.
- Estimate of the Yearly Amount of Narcotic Drugs Required for Medical Use in China, An*—W. H. Graham-Aspland, M. D. Pub. by The International
- Seattle Helps China Fight the Narcotic*—Margart Bunday. W. R., Page 222, July 14, 1924.
- War Against Opium, The*—W. H. Graham-Aspland. C. R., Oct., 1922.

12. Chinese Abroad

- China's Nationals in the Japanese Empire*—H. F. MacNair. W. R., Page 198, April 7, 1923.
- Chinese Emigration*—Prof. H. F. MacNair. C. S. P. S. R., Page 55, April 1923.
- China's Students in Foreign Lands*—H. F. MacNair. W. R., Page 214, July 14, 1923.
- Chinese in the Philippines, The*—H. F. MacNair. W. R., Page 68, June 16, 1923.

- Chinese Students in the United States, Toward the Redemption of the*—Li Keng-chang. W. R., Page 202, April 7, 1923.
- Educating Chinese in America*—Julean Arnold. W. R., Page 272, April 21, 1923.
- Glimpses of the Chinese Abroad.*—H. F. MacNair. W. R., Page 81, March 17, 1923.
- Manchus Toward Their Chinese Subjects Abroad, The Attitude of the*—H. F. MacNair. W. R., Page 118, March 24, 1923.
- Relation of China to Her Nationals Abroad*—H. F. MacNair. C. S. P. S. R., Page 23, Jan., 1923.
- Status of the Chinese in Siam, The*—H. F. MacNair. W. R., Page 302, April 28, 1923.

13. Sino-Japanese Relations

- Japan's Electric Grip on Penniless China*—Charles A. Dailey. W. R., Page 335, May 5, 1923.
- The Shantung Negotiations*—C. Chao. C. S. P. S. R., Page 80, Jan., 1923.

14. United States and China

- America Changing Her China Policy? Is*—W. R., Page 41, March 10, 1923.
- American Constitution and the Chinese Republic, The*—Robert McElroy. W. R., Page 337, Nov. 11, 1922.
- American Money and Chinese Road Building*—John Earl Baker. T. P., Page 56, Nov., 1922.
- American Opinion Regarding China Has Changed—Why?*—W. R., Page 133, June 30, 1923.
- American People Think of China? What do they*—W. R., Page 167, July 7, 1923.
- Chinese Constitution from the American Viewpoint, The*—Paul S. Reinsch. W. R., Page 420, Feb. 10, 1923.
- Chinese Friendship for the United States?*—John Hart. W. R., Page 20, Dec. 2, 1922.
- Principles and Policies in Regard to China*—Stanley K. Hornbeck. W. R., Page 263, April 21, 1923.
- Theory, History and Origin of U. S. Extraterritorial Rights in China.*—Robert T. Bryan, Jr. W. R., Page 336, Jan. 27, 1923.

15. The Christian Movement

- Achievement in Self-Support*—William A. Mather. C. R., June, 1923.
- Anti-Christian Movement, The*—V. P. Ting. W. R., Page 291, April 22, 1922.
- Anti-Christian Movement in China, The*—H. H. Brayton Barff. L. A., Page 198, July 22, 1922.
- Appeal of the Modern Mind to China, The*—F. E. A. Shepherd. C. R., July, 1922.

- Bible Distribution and the Chinese Church*—Carleton Lacy. C. R., July, 1922.
- Cheng Ching-yi—Chinese Christian.*—C. G. Sparham. M. R. W., Page 952, Dec., 1922.
- Chinese Church and Country Life, The*—J. Lossing Buck. C. R., June, 1923.
- Christians and Non-Christians Reply to the Anti-Religion Movement*—T. C. Chao. C. R., Dec., 1922.
- Christian Church and Rural Life in China, The*—Kenyon L. Butterfield. I. R. M., Page 182, April, 1923.
- Christian Dynamic for China, The*—J. L. Stuart. C. R., Feb., 1923.
- Christianity in China, Present and Future*—Milton T. Stauffer. M. R., Page 113, Feb., 1923.
- Christians Missions and Imperialism*—Tyler Dennett. C. C., Dec. 21, 1922.
- Church Union in China*—P. F. Price. C. R., April, 1923.
- Earliest Days of Christianity in China*—A. H. Rowbotham. C. R., I, Jan., 1923. II, Feb., 1923, III, March, 1923.
- Extraterritoriality and Missionaries in China*—Tyler Dennett. C. C., Page 625, May, 17, 1923.
- First National Conference of the Chinese Student Volunteer Movement, The*—P. C. Lin. C. R., Oct., 1922.
- Forgotten Pages in Mission History*—James W. Inglis. C. R., March, 1923.
- Great Deliverance, A*—C. M., Vol. XLIX, No. 3, March, 1923, Page 40.
- How a Missionary Works in China*—Charles E. Patton. M. R. W., Page 97, Feb., 1923.
- Impressions of Some Present Tendencies in the Christian Movement in China*—Kenneth Scott Latourette. C. R., Nov., 1922.
- New Church in China, The*—Alva W. Taylor. C. C., Page 1297, Oct. 19, 1922.
- New Missionary, The*—O. J. Goulter. C. R., May, 1923.
- New Stage in Missions in China, A*—Kenneth S. Latourette. M. R. W., Page 93, Feb., 1923.
- Obstacle to Missionary Work in China*—Rev. T. L. Sinclair. L. C., Page 9, May 5, 1923.
- Reaching China's Unenlightened Masses*—Edith M. Heeren. C. R., Oct., 1923.
- Recent Developments in the Methodist Episcopal Church in China*—Edward James. C. R., Jan., 1923.
- Social Gospel in China, The*—Sherwood Eddy. C. R., Feb., 1923.
- Then and Now.*—Arnold G. Bryson. C. R., May, 1923.
- Traveller to the West, The*—by a Traveller. C. R., Sept., 1922.
- Two Hundred Miles of Miracles*—W. H. Oldfield. C. R., I, Feb., 1923, II, March, 1923.
- Views of a Christian Leader in the Chinese Army.*—C. R., June, 1923.
- Visitor's Impressions of the National Christian Council, A*—D. Willard Lyon. C. R., June, 1923.
- What do Students in Christian Schools Really Think?*—Archibald Bullock. C. R., Jan., 1923.

- What the Chinese Are Thinking About Christianity*—C. R., I, Oct., 1922, II, Dec., 1922.
- What the Chinese Are Thinking About Religion*—T'u Hsiao Shih. C. R., May, 1923.
- Women and the Church*—Ruth Cheng. C. R., Aug., 1922.
- Work Amongst the Miao in Southwest China*—W. D. Huspeth. C. R., Nov., 1922.
- Work Among the No-Su, The*—C. N. Mylms. C. R., Mar., 1923.
- Work Among the Tribes*—A. G. Nicholls. C. R., May, 1923.

TENT EQUIPMENT

1. In addition to the tent itself, there will be required:

(1) A tool consisting of heavy iron chisel about 2' long by 3'' wide, with a wooden handle about two feet long for digging holes for the anchor posts.

(2) Heavy wooden mallet about 1' in diameter and the same length, with a handle about 3' long for driving the anchor posts.

2. Benches for the audience.

Each bench is in three parts: seat and the two pairs of legs. Seat is $7' \times 7 \frac{1}{2}'' \times 1 \frac{1}{2}''$. About 1' from each end of the seat is a mortise. This is 1'' wider on one side of the seat than the other, and instead of being cut on the straight, is cut on the slant, which with the slant of the two cleats added, makes a difference of $\frac{3}{4}''$ between the width of the top and the bottom of the mortise. Each pair of legs consists of four pieces of wood: the legs proper, $19 \frac{1}{2}'' \times 2'' \times 1 \frac{1}{4}''$, one cross-piece, and the top, the legs pass through the top and are wedged secure, so that each pair of legs is one solid piece. The top is $1 \frac{1}{2}''$ thick, and made to fit in exactly into the mortise, its ends being flush with the sides of the seat, i.e. one end is $3 \frac{3}{4}''$ wide at the top and 3'' at the bottom, broadening to $4 \frac{3}{4}''$ and 4'' respectively at the other end. When tapped into place with a light mallet, each pair of legs fits into the seat rigidly, and the bench can be moved about at will without the legs moving in the slightest degree. Any expansion or contraction in the mortise or top of the legs caused by changes in the weather, is taken up by the inch difference in the widths of the two ends, the legs being tapped in farther, or not so far, according as the wood has contracted or expanded. The legs are made to go outward at a slight angle, the difference being $2 \frac{1}{2}''$. Therefore the mortise at either end of the seat must be reversed,, as to narrower and wider ends, as in diagram, to allow legs to spread outward.

In packing the benches on carts, the legs are tapped out from the seats and packed by themselves, the seats are packed in pairs, the cleat of one fitting into the mortise of the other, thus saving considerable space. A light wooden mallet should be provided for setting up and knocking down the benches.

3. Platform, in two pieces, each about $6' \times 2 \frac{1}{2}'$ supported on two benches, with knock-down railing on three sides, cloth to enclose.

4. A knock-down table top about $3' \times 1 \frac{1}{2}'$.

5. Rack with pictures, hymn-sheets, etc.

6. Gasoline Lantern. One is sufficient for tent sq. area 1200 sq. ft.

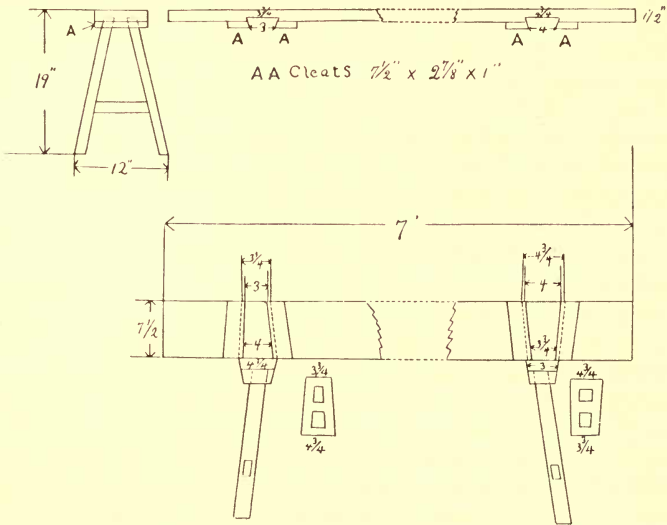

COVENANT OF THE ASSOCIATION

FOR THE SALVATION OF NATIONS THROUGH CHRISTIANITY

This Association was first organized in Canton about five years ago. Most of the Chinese pastors of the Canton Christian Movement were among its promoters. At first the membership was limited to Christians. Later this was changed. A prominent leader is Mr. George C. Hsu. In addition to many Chinese pastors as members, there are a few foreigners. A Sunday Bible class is one of the methods used. A weekly known as the "Christian Uplift" is published.

General Principles

- Art. I. To believe in God as "Absolute Reality".
- Art. II. To believe in Jesus Christ as personifying God.
- Art. III. To believe in the union of man with God.
- Art. IV. To believe in Christianity as the important factor in the salvation of nations.
- Art. V. To believe that all nations should be saved.
- Art. VI. To establish the Kingdom of Heaven on earth.
- Art. VII. To lead a pure and noble social life.
- Art. VIII. To rectify all errors and sins, others' as well as our own.
- Art. IX. To respect the rights of all persons.

Concerning One's Self

- Art. X. To pray and be conscientious.
- Art. XI. To be pure.

Concerning The Family

- Art. XII. To be monogamous, and to abolish concubinage.
- Art. XIII. To believe in the equality of rights between man and woman
- Art. XIV. To limit inheritance to one hundred thousand dollars in value.

Concerning Society

- Art. XV. To better the condition of the labouring classes.
Art. XVI. To promote equality between labour and capital.

Concerning the State

- Art. XVII. To realize a world democracy.
Art. XVIII. To respect the right of self-defence on the part of the people.
Art. XIX. To all persons, male and female, to give equal and free education of all grades, and to make elementary education obligatory for all.

CONSTITUTION OF THE CENTRAL CHINA TEACHERS COLLEGE

*Incorporated 1923 under the Law of the District of
Columbia U. S. A.*

The central object of the Corporation is the training of Christian Teachers and other allied educational service, and the whole title to this property is vested in the Board of Trustees, whose principal office is in Wuchang. There is no restriction as to their nationality. Two are appointed (in a manner, in the case of each mission, stated in the By-laws, to be amended only by consent of the mission concerned as well as of the Trustees) by each mission contributing full share to the union, and one by each mission contributing a half-share together with the Principal of the College (without vote) and possible co-opted members up to a limit of three.

This Board has complete power, including control of capital, sale of property, disposal of property or funds in case of withdrawal of a mission or dissolution of the union, appointment or dismissal of Foreign Staff (in consultation with Mission Concerned) and Principal, admission of new organizations, and relationships, financial and otherwise, with home boards. But freedom to attend Sunday services and hold special meetings is guaranteed the students of each Church.

Constituent missions with full share ("at least \$15,000 Mex. Capital, \$1,500 annual grant, and a foreign staff-member or equivalent") are at present the American Church Mission and Wesleyan Methodist Missionary Society, and they have named as their four trustees the official holders of four offices (Bishop, Chairman and President and Principal of two colleges in Wuchang. Those with half share (\$5,000 capital and \$1,000 grant or equivalent) are American Presbyterian Mission, London Mission, and Central China Christian Educational Association. The annual meeting is in September at the College and hitherto one or two additional meetings have been held annually.

Grants of Constituent missions are wholly applied to support of their students at the rate of fees in force at the time (and each mission now freely gives in addition a smaller upkeep and equipment grant and some a still smaller house-repairs grant.)

The second seat of authority in the College is the Board of Directors which consists of five members from every mission appointing two Trustees, and three members from every mission appointing one. Mode of appointment is stated in By-laws, alterable only by consent of Mission and Trustees. They control

general educational policy, current expenditure, rate of fees, entrance requirements, length of course, opening new departments or closing old ones, etc. They have no power to incur debt or financial responsibility save as authorised by Trustees. (Hitherto Mission appointments have secured that the staff is represented on this Board and encouragement has been given to the graduates to expect representation when their organization is well established.)

The third seat of authority is the Principal, who oversees the property and internal government and is responsible for administration, discipline, and curriculum entrance, promotion, and graduation tests receiving and dismissing students engaging Chinese teachers, fixing salaries, and supervising all instruction, and acting as Secretary and Treasurer of the Directors.

Any one of these three authorities have the right to make representations to any other on matters within the other's authority. There must also be a regular faculty meeting (or departmental faculty meetings) discussing the religious and social life, discipline, curriculum, internal well-being and progress of the institution and the health, progress, and character of the students. Resolutions of the Faculty Meeting are not operative without the consent of the Principal.

There is no provision for changing articles of incorporation but By-laws may be amended (after special notice) by a two-thirds vote of those present, provided such vote be a majority of the Trustees. Certain other actions, such as sale of property and admission of new missions, require similar notice and vote.

The Capital assets of the Corporation, after deducting depreciation, now total over \$76,000. The scope of the institution includes Practice and Model School and an Agricultural Department, and there is a special relationship to the Central China Christian Educational Association.

LIST OF ANTI-NARCOTIC BOOKS

- | | |
|---|--|
| The War against Opium | Peking International Anti-Opium Association and all booksellers. |
| Hearings before Committee of Foreign Affairs House of Representatives, On Narcotic Conditions in U.S.A. | Washington Government Printing Office. |
| "The Black Candle" By Judge Emthy Murphy (Opium and Narcotics in Canada and U.S.A.) | Thomas Allen & Co., Toronto, Canada. |
| Control of Opium in Japan | Japanese Red Cross Society, Tokio, Japan. |
| Reports of India Government Opium Department | Government Press, Allahabad. |
| League of Nations Reports of Advisory Committee on Opium Traffic | Geneva. |
| Questions and Answers | |
| A short outline for speakers on opium and narcotics | International Anti-Opium Association Peking. |
| An Estimate of Yearly Amount of Narcotics Required for Medical Purposes in China | International Anti-Opium Association, Peking. |
| Speech of Bishop Brent of New York at the League of Nations Opium Committee | International Anti-Opium Association, Peking. |
| Newspaper Supplement and Bulletins on Opium conditions in China | International Anti-Opium Association, Peking. |

INDEX

- Aborigines**;—102; 232.
 Abroad; Chinese students—
 342-352.
 Act to regulate trade—48.
 Adoption—510, 511.
 Advancement of Ed'n; Ass'n
 for—132; 133; 277; 301.
 Advertising—439.
 Agricultural conditions—412.
 „ training—122; 130.
 Alung; Influence of—81; 82.
 Alphabet (Chu Yin Tsu Mu)—
 318-324.
 American Schools—357.
 „ Red Cross—382-384.
 Animism—68.
 Anti-Footbinding Movement—
 419-421.
 Anti-Missionary feeling abroad
 —349, 350.
 Anti-Opium Ass'n; Intern'l—
 408.
 Anti-Religious Move't—52.
 Arabic; School of—78.
 Association for Advancing Good-
 ness—60.
 Association for Advanc't of
 Ed'n.—132; 277-288; 301.
 Association (Nurses') of China
 —375; 378; 379.
 Association Press (The)—470.
 Association for Salvat'n through
 Christ'y—529, 530.
 Association (Univ'l) for Unity
 of Religion—65.
 Autonomy—117; 159.
 Army; The—24-26.
 „ The Salvation—490-492.
 Art; Recent Articles on, 519.
 „ Books on—453; 516.
 Articles; Recent—519-526.
- Bandits**—7-9; 107; 111; 131;
 231; 433.
- Banditry; Causes of—11; Effect
 on the Church of—12; 104;
 Effect on the Country of—
 22-24; Banditry — Western
 Opinion of—450.
 Banks; Modern—33, 34.
 „ “Raiffeison”—412.
 Baptism;—266-268.
 Baptist Pub'n Soc'y—478.
 Bible Conference—178.
 „ Distribution—432-437.
 „ Institute; Hunan—175-180.
 „ Lesson Picture Cards—193.
 „ Phonetic used in teaching
 —325-339.
 Bible School; Daily Vacation—
 120; 129; 189; 195; 477.
 Bible study courses—282; 424.
 „ Sunday—436.
 „ teaching unsatisfactory—
 279.
 Bibliography—516-526.
 Birth Control—483-485.
 Blind; Schools for—103; 121;
 430.
 Board Deficits; Home—239.
 Bolshevism—16; 21; 57.
 Book Company; Mission—471.
 Books and Pamphlets, 1923; 133;
 516.
 Books; Recent—450-465; Demand
 for—110; in Chinese—465-482;
 on Sex and Family—483-485.
 Bookman ”; “The China—202.
 Boxer Indemnity Funds—1-6;
 264.
 Braille literature—431.
 Brothels in Shanghai; 413.
 Buddhism; Revival of—51; 110.
 „ Liang Chi-Chao and
 —459.
 Buddhist Activities—51; 120.
 Buddhists Christian Mission to
 —73; 75.

- Building Methods of the Shans—
227.
- Business Ethics; Changing—55.
- Campaign** (s) against vice; 113.
 " by Salvation
 Army—491.
- Campaign Evangelistic—100;
222-225.
- Candidates for service—261.
- Capture of foreigners—8-11.
- Catholic (Roman) Missions; 231;
266-269.
- Centenary Movement—258.
- Central China Christ'n Univ.—
122; 270.
- Central China Teachers' Coll.—
122; 531.
- Challenges to the Christ'n
Move't—95; 110.
- Changes in Industrial life—28-
43.
- Changes in feeling about China—
450.
- Changing standards in morals
and religion—50-58.
- Characters; The popular thou-
sand—310-313.
- Characters; Simplifying the—
319.
- Chi Yi and Industry—19.
- Child Labor—29; 34; 104; 155; 204.
 " Nurture; Books on—483;
485.
- Children's Meetings—223-225.
 " Refuge; Door of
 Hope and—416-418.
- Children (Value for) of Nat'l
Ed'l Survey; 299.
- China and the League of Na-
tions—406.
- China (the) Inland Mission—
180-182.
- China (the) Med'l Bd., Relation
to Pek'g Un. Med'l Coll.—363.
- China (the) Med'l Journal—375.
 " " Miss'y Ass'n—
374-377.
- China Christ'n Lit. Council—
443-445.
- China; Extra-terr'ty in—48.
 " Recent Books on—517.
 " " Articles on—520.
 " S. S. Union—191; 282.
 " Rural Dist's of—127.
 " To-day—1.
- Chinese Abroad;—523.
 " Books (recent)—457-
482.
- Chinese Christian Writers—438;
444; 447.
- Chinese Church and Changing
China—90; 100; 131-136.
- Chinese College Men; Call for—
109.
- Chinese Farmers—127.
 " Home Miss'y Ass'n—
124; 172; 174.
- Chinese Immigrants (in Canada)
—498-500; (in U. S. A.)—497.
- Chinese Immigration (laborers)
—494-496.
- Chinese in Med'l Work—363.
 " Rel. Orders; 267-269.
- Chinese Islam—78.
 " Christ'n Lit. Council—
443-445.
- Chinese Leadership—164-169;
245.
- Chinese Prosperity; 498.
 " Responsibility—115; 125;
218; 220; 245; 249; 429.
- Chinese Students in U. S. A.—3.
 " Support looked for—240.
 " Workers and Mission-
aries—94; 124; 241; 245.
- Chinese Workers; Train'g Rural
—210.
- Christian (China) Lit. Council—
443-445.
- Christian Conf. (Nat'l) and
Ind'sm—388.
- Christian Council (City)—100.
 " Endeavor Union—196;
249; 471.
- Christian Ed'l Ass'n—282-291.
 " Indust'l enterprises—
394-398.
- Christian Leadership—91; 105;
118; 134; 164; 169; 178.
- Christian Literature—438-442.

- Christian Literature Soc'y—446; 446-469.
- Christian Mission to Buddhists—73; 75.
- Christian Move't; Art. on—524-526; Books on—519; since the Rev'n.—89-91; 460.
- Christian Periodicals—439.
 „ Prestige; 108.
- Christian Pub'ns—466-482.
 „ Publishers' Ass'n—202.
- Christian Students in Gov't Schools; 281.
- Christian Unity—93; 182; 375.
 „ Work among the Loi; 232; Miao, 232; Moslems, 86; Soldiers, 504-507.
- Christian Work and the Bandit Sit'n—7; 12.
- Christianity and Industrialism—30; 40; 244; and Chin. Students abroad—346-348; and Rural life—127-130.
- Christianity; Influence of—53; 92; 125; 421.
- Church and Opium—399-402.
 „ as an employer—392.
 „ (Commis. on) and Industry—390.
- Church; Community—143.
 „ Effect of Banditry on—12-14; Effect of Famine relief on—106.
- Church Federation in cities; 184.
- Church Gov't; Democracy in—123.
- Church (Great) vs the Mission—245.
- Church; Indigenous—115; 116; 241.
- Church; Instit'l—108.
 „ Lit. Com'ce; New Books of—469.
- Church Members; Responsibility of—206.
- Church; N. C. C. and the—154.
 „ of Christ in China—114; 117; 248.
- Church Property destroyed—8-10; 13.
- Church; Rural—127; 128; 148; 210-212.
- Church; Y. W. C. A. and—168.
- Church Unity—152.
- Church's Opportunity with Industry—30; 44; 95; 383-393; Opportunity among Gov't students—110; among Moslems—87-88.
- Church's Responsibility for Chinese abroad—502; for Social Welfare—155; for the Home—125.
- Chu Yin Tsu Mu—110; 320-323.
- Circulation of Scriptures, 1923—436.
- City Christ'n Councils—100.
- Civics in Community Centers—423.
- Clairvoyancy—58.
- Classic Virtues—56.
- Classical Religion—68.
- Classics; The—60-69-72.
- Classified Index of Christ'n Lit.—203.
- Colleges for Women—307.
- Colporteurs; Value of—433.
- Commerce; Articles on—522.
- Commercialized Vice—53.
- “Commoners' Weekly”—315.
- Community Centers—422-425.
 „ Church work—104; 143-145.
- Community Life; Christianizing—243.
- Condition of students abroad—344.
- Condition (Physical) of students in Miss'n Schools—367-373.
- Conference, Gov't and Mission Ed'lists.—276.
- Conference; China and Japan Morphia—406.
- Confucian Ass'n—70.
 „ „ “Monthly”—69.
- Confucianism; Present—67-72.
- Consciousness (Christian); Creation of a—160.
- Consciousness (Self) of Chin. Church—114.
- Continuation Schools—315.

- Contributions from Chinese—112, 113, 123.
 Control; (Chinese)—232; 247; 249; 250.
 Convention (First Nat'l) Y. W. C. A.—168.
 Coöperative Plans—35.
 „ „ for Rural Betterment—130.
 Coöperative Societies—17.
 Coöperation and Unity—93; 106; 121; 179; 185.
 Coöperation at the Home Base—263.
 Coöperation in Christ'n Lit.—446; in Ed'n; 125; 270-273; 356; in Ed'l work, Gov't and Miss'n—277; in Moral Welfare work—113; 118; in Nat'l Ed'l Survey—298; in Christ'n Lit.—232; 443; 446; 448; in work of Y.M.C.A.—158; 163; Promoted by N.C.C.—156; by Y.W.C.A.—170.
 Coördination of Tract Soc'ies—448.
 Correlation of Curricula—281.
 Cost of Army—24.
 „ Living—35; 109; 261; and Self Support—141.
 Cotton planting—489.
 Council (Int'l) of Nurses and N. A. C.—379.
 Council on Health Ed'n—360; 367; 379.
 Council (Nat'l Christ'n)—147-157.
 Country Church; Com. on—148.
 „ ; Confuc'ism in—71; Ed'n by R. C. Ch. in—268; Evangelistic Work in—120; 210-212; Foot-binding in—421; Paid Min'try in—141; Self-Support in—137; The Church in—127-137.
 Courses and Degrees off'd by P. U. M. C.—364.
 Cure for Banditry—14.
 „ Drug Habit—488.
 Curriculum (Stand'd) estab'd by N. A. C.—379.
 Daily Vacation Bible Sch.—120; 189; 477.
 Dame Adelaide Anderson—391.
 Data (Essential) of Fam. Rel. Work—410.
 Debts; Chin. Gov't—25.
 Deepening Spiritual Life—93; 95; 126; 147.
 Defects in Science Teaching—285; in Students; Table of Phys'1—371.
 Deficits; Board—239.
 Degrees (Courses and) offered by—P. U. M. C.—364.
 Democracy in Ch. Gov't—123.
 Denominational Ed'n Unsatisfactory—281.
 Disbandment of soldiers—26.
 Disorganization of Cent. Gov't—56.
 Distribution of Christ'n Lit.—233-449; of Bibles in—1923; 432-437.
 Disturbances (Fukien)—111.
 Divorce; Law in regard to—509.
 Door of Hope and Children's Refuge—418.
 Drunkenness among Mongols—237.
 Earthquake (Japanese) an opportunity—106; 132; brings loss—432; Murders during—500-502.
 East China Christ'n Ed'l Ass'n—105.
 East China Christ'n Colleges; Summer School of—271.
 Eclectic Movements—52.
 Economic Pressure and Banditry—11, 12.
 Economic Principles of Confucius—70.
 Educated Leaders demanded—109.
 Education and Industry—35, 36.
 „ ; Ass'n for Advance't of—133; 277; 288; 391; (Denom'l) results of—281; (Health); Council on—360; 379.

- Education in Country—268, 269.
 „ Sanitation; Rural
 130.
 Education (Medical) generally
 Union—374; 376; Articles on—
 522; Books on—578.
 Education (Minister of); Friend-
 ly attitude of—275.
 Education (Popular) Ass'n—316;
 Continuation Schools of—315.
 Education (Popular) Move't—36;
 309-317.
 Education; Progress in—105; 120;
 133; 274; 488.
 Education (Relation of Christ'n)
 to Gov't—274-277; Sci. Measure-
 ment of—288-296; Unification
 in—270-273.
 Education (Religious); Attempts
 to improve—135; 151; 282;
 Present Situation in—278-282.
 Educational Commission (Re-
 com'd'n's of)—271; 273.
 Educational Ass'n; China
 Christ'n—272; 274; 291.
 Educational Tests—289.
 „ Work in Community
 Centers—422; for the Blind—
 430.
 Educational Union; Pub'n's of
 W. China Christ'n—472-474.
 Edward Evans' Sons; Pub'n's of
 —471.
 Emigration—493-496.
 Employer and Employee—44.
 Endeavor Union; Christ'n—196.
 Endowment Societies—101.
 Engineers; Need of—37.
 Epidemic Prevent'n—358.
 Epworth League—198.
 Equipment (Science) inadequate
 —283.
 Ethical Standards—377.
 Evangelism—148; 262.
 Evangelistic Campaigns—100;
 111; Bands—120; 141; 176.
 Evangelistic Work and Banditry
 —13; 14; in Villages—129-208;
 of Colporteurs—434; Some
 Problems of—205-210; Use of
 Tents in—222-225.
 Evils of Modern Industry—39; 42.
 Examinations (Physical)—367;
 System of N. A. C.—379.
 Extraterritoriality—9; 46-49.
Factories—29; 32.
 Factory work;—36; 42, 43.
 Family Life; Books on Sex and—
 483-485; Problems of—56; 57;
 95.
 Famine Prevention—412.
 „ (Rel'n of) to Opium—
 400.
 Famine Relief Work—1921-22;
 410-412; and the Church—106.
 Farmer; Industrial Opportunity
 of—19; 32; Position of the—
 18; 127.
 Fasting—183.
 Federation (Church) in Nanking
 —184-188.
 Feng (General)—14; 504-507.
 Fiction; Recent Books of—452.
 Filial Attachment replaced—57.
 Finance; Recent Articles on—
 522.
 Financial Difficulties at Home
 Base—239; 261.
 First Cause ”; “ The Great—
 62; 64.
 Five Religions; The—59; 64.
 Foot Binding (Anti-) Present
 Situation of—419-421; 489.
 Foreign Workers; Question of—
 91; 104; 106; 241.
 Foreigners and bandits—8, 9,
 10, 11.
 Forward Movement; General—
 80; 84; 147; Methodist—259.
 Foundation Character Course—
 310.
 Free Marriage—509.
 Four Religions (The)—92.
 „ Traditions “; ” The Learn-
 ed Soc'y of—65.
 Friends' Council; Pub'n's of—478.
 Fukien; Progress in—111.
Gambling; Antidotes to—424;
 Effects of—231; prohibited in
 Shansi—489.

- General books on China—450.
 General Feng's work—14; 504-507.
 General Forward Move't—80; 84; 147.
 Gifts from Chinese—112, 113.
 Goodness; Ass'n for Advancing 60.
 Gospel; Recons'd'g method of present'g—152.
 Government disregarded—56; influenced by Banks—34; recognizes Moslems—79; responsibility for Opium—400; (Sinkiang) anti-Christ'n—237.
 Government students; Opportunities among—110; 274-277; 281; patriotic—302.
 Graduate work in P.U.M.C.—364.
 Group Conferences—148.
 Growth (Num'l) of the Church—91; 95; 213; 232; of Y.W.C.A.—170.
 Guilds; Changes in—37.
- Hainan**; Map of—230; Miss'y work in—230-234.
 Hakkas in Hainan—230.
 Hall of Hospitality—76; 77; Hallock (H. C. G.); Pub'ns of—472.
 Hand work; 32; 44; 394-396; Conditions of—395.
 Hanyang and Nine-hour day—36; 37.
 "Head Men" Evil—39; 40.
 Health Ed'n; Council on—369; 379.
 Health (Public) Move't—358-362.
 Health (Public) Work—312; 376; 396; 423.
 Heaven; Sacrifice to—68.
 Height and W't Tables; Chin. and Amer.—360.
 Heilungkiang; Miss'y work in—173.
 Heterodox Sect of Moslems—78.
 Home Base; Finan'l difficulties at—239; Rel'ns with—251.
 Home Group School (for'n children)—354-356.
 Home Life and modern Ind'y—32-43; Importance of Ch'n—125; 157; 157; 279.
 Home Miss'y Ass'n (Chin.)—172-174.
 Home Study for Ch'n workers—217.
 Honesty in Business—55; Industry—37.
 Hopefulness in 1923—132.
 Hospital Technicians—375.
 Hostels—270.
 Hsiung Hsi-Ling (Mme) and Popular Ed'n—313; 316; 317.
 Hunan Bible Inst.—175-179.
- Illiteracy**; Campaign against—105; 120; 309; 311; Efforts to meet—161; 442.
 Illiterates and phonetic—325-339.
 Immigrants to Canada—498-500; foreign lands—502; U. S. A.—497, 498.
 Indemnity (Boxer) Funds—1-6; Question of—13.
 Independence of the Young—55.
 „ (financial) important 149; 245; Signs of—101; 113; 115.
 Index (Classified) of Ch'n Lit.—203; 466.
 Indigenous Ch'n Lit. needed—150; 193.
 Indigenous Church—105; 115; 156; 244, 245; Advance towards—123, 124; 134; begun through Biola Band—178.
 Indigenous religious Ed'n needed—280; 282.
 Individualism in business—55.
 Industrial Ass'n (Nat'l Ch'n)—396.
 Industrial Conditions and Ch'n publishers—203.
 Industrial Conference—389.
 „ Enterprises; Ch'n—394-398; 417.
 Industrial Homes for girls—492

- Industrial Life; Changing—28-45; 122; 388-393.
 Industrial Secretaries (Y. W. C. A.)—168.
 Industrial Survey—29.
 „ Work for the Blind—431; among ricksha men's families—428.
 Industrialism and the Y. M. C. A.—160; Christianity and—30; 95; 150; 392.
 Industry; Commiss. on the Ch. and—390-392; Recent Art. on—522; Women in—35; 43.
 Inheritance laws—510.
 Institutional Church—108; 118; 144; Bookstore in—435.
 Instruction; Soc'y for Moral—16.
 Intellectuals claim attention—441.
 Intelligence tests—289.
 Interdenominational Coöperation—185.
 International Action and Opium—400; Council of Nurses—379; Fam. Rel. Com.—17; 410-412; Miss'y Council—1923; 265; Relationships—157; 162; 524; 518.
 Interpretations of China by recent books—452.
 Islam; Chinese—78-85.
Japan Morphia Conf.; China and—406.
 Japanese earthquake; Help for—106; Murders during—500-502.
 Journal; China Med'l—375.
 „ (Quarterly) for Chin. Nurses—379.
 Jurisdiction—46, 47.
Kansu; Leaders from—79.
 „ Moslem work in—86.
 Kuling Med'l Miss'n—385-387; Summer Sch. of Rel. Ed'n—282.
 Kung Li Hui—248.
 Kuo Yu Wen—440; 459; 463.
 Kwang Hsueh Pub'g House; Pub'ns of—476.
Labor (Child)—34; 104; Ch't'n Pub'rs and—204; N. C. C. and—155; 389; Organizations—29; 37; 38; 44; Standard (Church) endorsed—390.
 Land Tax and Opium planting—399; 404.
 Language (s) a difficulty; Many—436; (Chinese) Books on the—454; 517.
 Lao Yang Ren—7; 8; 11; 23; 404.
 Law (Study of) in Gov't Sch.—302; (Chinese) and Women—508-511.
 Lawlessness—56; 57.
 Lay workers; Volunteer—135.
 Leaders need spiritual renewal—208.
 Leaders needed—163; 205; (Training of) imperative—242.
 Leadership by Chin.—91; 105; 109; 124; 134; 164; 169; 178; in Manchuria—123-125; encouragement of—157.
 Leadership by Church in reforms—118.
 Leadership important—146; 188.
 League of Nations; China and the—406, 407.
 Learned Soc'y of Four Trad'ns—65.
 Lecture Work by Y. M. C. A.—161.
 Lepers; Work among—234.
 Lesson Helps in S. S. Work—192.
 Liang Chi-chao's Lectures—459.
 Liberty; Growth in—123.
 „ in Theol. Ed'n needed—243.
 Libraries in Community Centers—423.
 Life in 1923; Signs of—131.
 „ Problems in S. S. Lit.—193.
 „ Rural—155.
 Living; Cost of—35; 109; 141.

- Living; Wage; Does the Ch. pay a—392; in Ch'n Industries—345.
- Lincheng; Attack on Blue Expr.—9; 23; 156; 450.
- Literacy among Moslems—88.
 „ Women—105.
- Literates volunteer for Pop'lar Ed. Move't—311; 312.
- Literary Activity among Chin—438; 445; 457; 454.
- Literary Rev'n (The)—399.
- Local Preachers—217.
- Logos; Doctrine of—74.
- Loi; Work among—232.
- London Miss.; in Chihli—141.
- Lutheran Bd. of Pub'ns; Pub'ns of—475.
- Magistrates** in Shansi—483.
- Managers (Salaried) *vs* owners—32; 44.
- Manchuria—123; 124.
- Manchurian Plague Prevent'n Service—376.
- Market for Ch'n Ind'l products—396.
- Marriage (Books on)—483-485; Laws in regard to—509.
- Measurement; Scientific Ed'l—288-296; 298.
- Mecca; Pilgrimage to—82.
- Mechanics needed—36.
- Medical Board (China) and P. U. M. C.—363.
- Medical College; Peking Un.—363-366.
- Medical Ed'. generally Union—374; 376.
- Medical Journal; China—375.
 „ Mission (Kuling)—385-387.
- Medical Miss'y Ass'n (China)—374-377.
- Medical School; E. China Union—271.
- Medical Work; Few volunteers for—261; and Community centers—423; in C. Asia—236; Hainan—234; Preventive—359, 369; 362; (Rural)—129.
- Meetings for Children—223; 225.
- Membership (Basis of) in Y. W. C. A.—167; in S. V. M.—340; 341.
- Membership; Church—91; 123; 211.
- Mencius and Socialism—18.
- Merchants and Opium—498.
 „ Militarism—27.
- Message of Chin. Church (in 1922)—93.
- Methodist Centenary Move't—257.
- Methodist Episcopal Miss.—251.
 „ Jubilee—114; 259.
- Miao Tribes; Christ'ny among the—232.
- Militarism and Opium—400; 401; 403; 405; Cause of—22; Effect upon Ind. of—32; Merchants and—27.
- Militarists—23-25; supported by Opium—399.
- Military converts of the Salv'n Army—491.
- Middle Schools; Science teaching in—285; in Shansi—488.
- Ministry (Ed'd) demanded—109; 134; 245; Quest'n of a paid—149, 141; Stud. Vol. Move't for—349; 344.
- Mixed Court Home—414.
- Missions and Social Work—422; 425.
- Mission Book Co.; Pub'ns of—471; Presses; Value of—204.
- Missions promote hygiene—359; (Roman Catholic) in China—266-269.
- Mission Sch. grad's; Vocat'l int's of—303; Phys. Exam. of—370-373.
- Mission to Buddhists (Nanking)—73; 77; to Mohammedans—84; 227, 228.
- Mission Work in Hainan—231; Int. in—238-264.
- Missionary (Anti) feeling abroad—349.
- Missionary Ass'n (China Med.)—374-377.

- Missionary Candidates—152; 252; 253; 261.
- Missionary Receipts and Mod. Move'ts—241.
- Missionary Sit'n in Gt. Brit.—260-265.
- Missionary Soc'y; Chin. Home—172-174; Nat'l—124.
- Missionary Zeal of R. C. Sisters—268, 269.
- Missionaries; Need of Better—243; 252.
- Modern Mach'ry; Introd'n of—28; 32; 42.
- Modern Methods of work—243.
 „ Move'ts—60; 243; Effect upon Islam of—84, 85; Effect upon Miss'y rec'ts of—241.
- Mohammedanism—78-85; in N. West—78; 235-237; Unity of—79-81.
- Mohammedans; Miss'y work for—80; 84; 237.
- Mongol Tribes; Work among—236, 237.
- Monopolies; Opium—399-403.
 „ Conditions in the Far-Eastern—406.
- Moral Welfare League of Sh'ai—413-415.
- Morphia Conf.—406, 407.
- Mosques as Inns—81.
- Moral Ass'n; Universal—60.
 „ Instruction; Soc'y for—61.
- Moral Welfare Ass'n—113.
- Morality (Sex); Standards of—56-58; 131.
- Morals and Relig'n; Chang'g standards of—59; 60; in Country—72; New Thought Move't and—71.
- Motor Roads in Hainan—231.
- Murder of Foreigners—9, 10.
 „ Chinese—509-502.
- Nanking Church Council—184; Miss. to Buddhists—76; Sch. of Arabic and Persian—78.
- Nanking (Univ. of) Pub'ns of—477.
- Nanyoh Bible Conf.—178.
- Narcotics for medic'l purposes—409; Opium and—399-409; 488.
- National Ass'n for adv't of Ed'n—132; Ch'n Conf.—94; 143; 232; 388; 436; Conv. of Y. W. C. A.—168; Miss'y Soc'y in Manchuria—124; Public Health activities—358.
- National Spirit (New)—96; 312.
- National Ch'n Council—105, 106; 133; and Ch. Unity—93; and Home; 150; and Opium—149; Com. on Rural Problems—130; Com. on Work for Blind—430; Rel'n of S. S. Union to—172.
- New Cht'n approach to Buddhism—73-77.
- New Cht'n pub'ns—466-482; Nat'l Spirit—96; Sect of Islam—83; Thought Move't—71; 242; 457; 461.
- Newspapers in Sinkiang; No—237.
- Nine Hour Day tried—37.
- Non-Cht'n Relig'ns and the Logos—75.
- Normal School for Teachers of the Blind—431; Girls' Union—122; (Union); Name changed of—122.
- North China—106; 107.
- Northwest China; Work in—235-237.
- Nurses' Ass'n of China—379; and Med. Miss. Ass'n—375; Pub'ns of—477.
- Nurses' Day; Nat'l—380; Quarterly Journal for Chin.—379; Work in China; 378-381.
- Obituaries**—512-515.
- Officers; Train'g Sch. for Salv'n Army—490.
- Open Ports; Ind'l changes in—32.
- Opportunity for Evan. work—208; for influence on Ed'n—277; for serv. in Com'ty Ch.—145; among farmers—127-130; among Gov't stud.—110; among Moslems—87.

- Opium and narcotics—399-409; 488.
- Opium; Enforced planting of—114; 236; 399; 493; 409; Gov't monopoly of—399; 493; Gov't responsibility for return of—149; 490; merchants and—498; Militarism and—490; 491; 408; Smuggling—402; 494; 488.
- Opium Users; Officials as—407; 408; 487.
- Orders (For. Relig.) in R. C. Miss'ns—236.
- Organizations in Labor—37; of Chin. Stud's abroad—345.
- Organization of Islam—80, 81.
- Oriental Sec'y of Stud. Cht'n Fed'n—162.
- Paid Ministry**;—140, 141.
- Pei Hua (Spoken Lang.); Alphabetization poss. in—318; Pop'ty of—309; 318; 320.
- Parents' occup'ns; Stud'ts' interests and—305.
- Pastors; Scarcity of—232.
- Peking Council of Churches—187; Union Med'l Coll.—363-366; Univ. and Shantung Univ.; Coöp'n by—270; Wom. Med. Coll.—270.
- Periodicals; Ch'n—439; New—457.
- Persecution of Moslem converts—80.
- Philanthropy—53, 54; 139.
- Philosophy of Life; Books on—450.
- Phonetic Particle—320.
- Phonetic Script—105; 442; Value of—110; 366.
- Phonetic systems used in teaching illiterates—325-339.
- Photographs and Slides—258.
- Photography; Spirit—63.
- Physical Exams. of Miss. Sch. Stud.—367-373; Tables—370-372, 373.
- Picture cards; Bible lesson—193.
- Pilgrims entertained—76; a unifying force—82; to tombs of Moslem saints—83.
- Plague Prev'n Serv. in N. Manch.—358; 376.
- Planchetto—52; 60; 63; 64.
- Planting of Opium; Enforced—114; 403; on Russ. border—236; increased in—1923; 399; 403.
- Play grounds—124.
- Police character study—314.
- Policy in Ed.; Common—272.
- Poetry; Modern—463.
- Political disturbances—120; 131.
- Poor; Care of—121; 491; 492.
- Popular Ed'n and Pei Hua—310; Ass'n (Nat'l)—316; in Sanitation—130; Move't; 36; 309-317; 488.
- Port cities; Ind'l changes in—32.
- Port cities; Influence of—41.
- Postal Savings Banks—35.
- Post-grad. study by Stud. Vol.—255.
- Poverty; Increase of—34.
- Power; of the Purse offered—123, 124; Spiritual—207; 209.
- Practical training for Rural workers—210.
- Preachers exchange—101; Local—217; 220; Mobile force of—141; 225; in N. China; Need of—109; Voluntary—218.
- Prejudice; Race—345; 497, 498.
- Presenting the Gospel (Method of) reconsidered—152.
- Press; Ass'n—470.
- „ Value of Mission—204.
- Prestige of the Church—108.
- Pride in the Church—135.
- Primary Schools in Ricksha Miss.—427-428.
- Primary Teachers; Training of—105.
- Primeval ancestor (Gt. First Cause)—62-64.
- Principles; Soc'y for Preserving Four—55.
- Prison Work welcomed—120.

- Problems (Life) ill'd in S. S. work—193; (Women's); Books on—462, 463.
- Processions; Cht'n—112.
- Production; Univ'l—19.
- Products; Changes in—32.
- Progress (Cht'n) since the Rev'n—89-91; 132; of Ch. Union Coöp'n—93; 103; 106.
- Property (Women's); Laws in regard to—508.
- Prosperity (Chin.) in the U.S.A.—498.
- Public affairs; Interest in—151.
- „ Health Move't—358-361; work of C.M.M.A.—375.
- Public Opinion—132; 244; Service by Magistrates—487.
- Publications by Med. Miss. Ass.—376; Recent Chin.—466-482.
- Publishers' Ass'; Ch'n—202-204.
- Punishment by Nat'ls—47.
- Purifying the Heart; Soc'y for—59.
- Race** Consciousness among Moslems—79; 84.
- Race Prejudice—345; 497; 498.
- Receipts (Miss'y) and Mod. Move'ts—241.
- Record System; Accumulative—292.
- Recreation in Community Centers—424.
- Red Cross in China—382-384.
- Redistribution of Forces—129.
- Reference; Books of—516.
- Reform (s); Church leadership in—118; Recent Art. on—522.
- Relations betw. Chin. and Missionaries—94; of Y. W. C. A. to Church—168.
- Relief Work of Red Cross—383-384; by Ricksha Miss.—426; 429; Famine—410-412.
- Religion and the Community Center—424; Articles on—52; Ass'n for Unity of—65; Books on—517; Changing stand. in morals and—50-52; Confucism as—68; of the Shans—227; Philanthropy and—53; (Trained teachers of) too few—278; World—101.
- Religions of China; Christ'ty and the—50; 59; Renaissance and—110.
- Religions; Secrecy in—60; The Four—92; Logos hidden in—75.
- Religious and Soc'l work in Cht'n Ind.—396; in P.U.M.C.—365.
- Religious aspirations general—65; 243; Liberty clause—70; needs; Students'—281; Orders in R.C. Miss.—266; practices; Old—54; move'ts in China—59-66; Textbooks; Poverty of—281.
- Religious Ed'n; need of—135; 151; Summer Sch. of—282.
- Religious Tract Soc'y of W. China; Pub'ns of—474; for China—448; Pub'ns of—478-482.
- Renaissance; Hist of Europ.—461.
- Renaissance; Move't—110; 279; 433.
- Research; Art. on—519; Books of—454; 458; 517; Dep't of Y. M. C. A.—165.
- Research work by M. M. A.—377; work by P. U. M. C.—364.
- Responsibility of Ch. members—206; 245; 247; 249; 250; 251; (The Ch's) for the Home—125; for Social Welfare—155.
- Rest of one day in seven—155.
- Retreats—149; 155; 165; 445.
- Revolution; Cht'n progress since—89-94; The Literary—309.
- Ricksha men; Work for—426-429.
- Righteousness emphasized—59.
- Roman Catholic Missions in China—266-269; in Hainan—231.
- Romanization;—322-324.
- Rural Church—127-130; 148; 210; 211; Education—129; Life

- 31, 32; 57; 155; Problems; Int'l Fam. Rel. Com. and—410.
- Rural Districts; Confuc'ism in—72; and Indigenous Ch.—156.
- Russian Bolshevism—16; share of Boxer Indemnity—4.
- Sacrifice to Heaven**—68.
- Safeguarding of Workers—155.
- Salaries—139; 140; 205.
- Salvation Army—490-492.
- „ through Cht'nity; Ass'n for—529; 530.
- Sanitation; Education in—130.
- Savings Banks—35; 62.
- Schools and the Church—105; 112; 125; 133; (British) study Miss'ns—264; for For. children—353-357; for the Blind—103; 121; of Nursing standardized—380; Phys. Cond. of stud. in Miss.—367-373; (Public) in Shansi—488; (Summer) of E. China Coll.—271.
- Schools (Sunday); 91; 192; 193; Union; 189; 192; 194; The Classics in—72; Worship of Confucius in—68.
- Scholars accessible—208; and Anti-footbinding—420.
- Science Board; Nat'l—277; Courses (Summer)—286; Ed'n in China—283-287.
- Scientific Discoveries in Hainan—231; Ed'l Measurement—288-296; 298.
- Scriptures; Translation into Turki—236.
- Secrecy in relig. organiz'ns—30.
- Seizure of Gov't funds—25.
- Self-Assertion in Theology—117; Consciousness—114; Expression—116; Gov't achieved—117; Respect of Ricksha men—428.
- Self-Support—104; 109; 112; 117; 137; 141; Relation of spir'l life to—140; The Status of—137-142; 240; 425.
- Sericulture encouraged—489.
- Sericulture Pub'ns on—477.
- Service of C. M. M. A.—374-377; in Community Ch.—145.
- Services; Children's—223; 225.
- Sex and Family life; Books on—483-485; Morality—56.
- Shans (The)—223; 227-229.
- Shansi attacks foot-binding—420; 489; encourages sericulture and cotton—489; Gen. Yen and—486-489; prohibits gambling—489; promotes pop'lar ed'n—488; suppresses Opium—400; 405; 487.
- Shantung Cht'n Univ.; Pek. Wom. Med. Coll. and—270.
- Shelters for Ricksha men—428.
- Shennung; the socialist—18.
- Short Stories; Social—464.
- Signs of the Times Pub'g House—471.
- Silk Industry; Survey of—30.
- „ worm raising; Pub'ns on—477.
- Sisters; Zeal of Chin—268.
- Six Religions Soc'y—101.
- Skilled Mechanics; Wages of—35.
- Skilled Tradesmen; Condition of—35.
- Slides (Lantern) prepared—258.
- Smuggling Chin. into the U. S.—494-496; Opium—402; 404; 488.
- Social Evil; Combatting the—413; 414.
- Social and Pol'cal Sc. Ass.—3; Centers—422; cleavage betw. Mohammedan and pagan—80.
- cond'ns of Stud. abroad—344; consciousness awakened—145; life and Women in Ind.—43; Ch's influence on—118; 201; 125; 185; problems; Art. on—523.
- Social Serv. and Eclectic Relig'ns—52; Status of laborers—36.
- Social Welfare work by Salvation Army—491; work and the Church—133; 244; workers needed—104; 135.

- Socialism and the Guilds—21; in early Hist.—18; Nat'l Univ.—16; Practical—20, 21; Students and—16; 439.
- Socialistic Tendencies—16-20.
- Society for Cht'n Endeavor—196; for Moral Instruct'n—61; of Four Principles—65; for Purifying the Heart—59; six Religions—101.
- Societies; Chin. R. C.—267-239; Varying stand. of Miss.—252.
- Soldiers; and Bandits—111; Cht'n work among—504-507; Numbers and cost of—24, 25.
- Soviet Russia and Boxer Indemnity—6.
- South China; Ind'l life in—28; 114.
- Spirit Photography—63.
- Spiritual awakening in Manch—125; interpretation of life—461; object of the N. C. C.—154; renewal needed—107; 208; 209; 265.¹
- Spiritual life; Deepening the—93; 95; 126; 147; 183; Relat'n of Independence to—149; *vs* mat'l growth—112; 113; 154.
- Spiritualistic features of move'ts—52; 58.
- Standards (Common) in Ed'n—272; (Ethical) of M. M. Ass'n—377; Industrial—390; of Nat'l Cht'n Industries Ass'n—397; set by Nat'l Ed'l Surv.—298; (Varying) of Miss. Soc'ees—252.
- Standardized Schools of Nursing—380; Spoken Lang.—318; Tests—289.
- State Relig.; Confuc'm as—68; 70.
- Stereopticon in Teaching—313.
- Stewart (Lyman and Milton) Debt to—179.
- Students Abroad—343-352; 496, 497; and Cht'n Lit.—349; Pop'r Ed. Camp.—312; and Socialism—16; 439; as Evangelists—112; Teachers in villages—129; assist in Nat'l Surv.—294; consciousness; Creation of—160; (Gov't); Patriotic motives of—362; Ht. and Wt. Tables of Chin. and Amer.—369; Interests and Parents' Occupations—305; 1923 a hard year for—159; (Phys. Cond. of) in Miss. Sch.—367-373; relig. needs not met—281; vocat'l int.—301.
- Students Vol. Move't—102; 126; ~~254~~; 340-342; Coll. Grad. in—253.
- Student (s) Volunteers in For. Serv.—253.
- Strikes—29; 32; Sept. to Dec. 1922; Table of—17.
- Style of Cht'n books—440.
- Succession; laws in regard to—510.
- Summary of Nat'l Ed'. Survey—297-300; of Phys. Exam. of Stud.—373.
- Summer Conf.—345; 348; Inst. of Ed'l meas'nts—290; Science courses—286.
- Summer Sch. of E. China Cht'n Coll.—271; for poor Children—366; of Relig. Ed'n. Kuling—282.
- Sunday; Bible—436; observance—118; 241.
- Sunday School Union—191; 282; Correlation of week-day curricula with—281; Increase in—91.
- Superstition—54; 57, 58; 229.
- Supply of Miss'y candidates—253.
- Support for Miss. Work—238; of the Army—2-4; 25; Y.M.C.A.—158.
- Survey; Industrial—29; Meth. Centen'y—257; Nat'l Ed'l—290-295; (Prel'y summary of)—297; Nat'l Ed'l (Summary Table)—300; of Cht'n Ed.—94; Silk Ind.—30; Volume—93, 94.
- Swastika Soc'y—64.
- Symbol for Christianity in Tao Yuan—62; for Mohammed—63.

- Szechwan Cht'n Council—100 ;
Sch. for the Blind—103 ;
Statistics—102.
- Tai**; Missions to the—226-229.
- Tao Yuan—52 ; 62.
- Tax (es) for support of Army—25.
,, (Land) and Opium—409.
- Teachers for S. S. Work—192 ;
194 ; Shortage of trained—281 ;
284 ; (Trained) of religion—
278 ; Primary—105 ; 488.
- Teachers' College ; C. China—
122 ; 531 ; 532 ; for E. China—
272 ; in Shansi—489.
- Teaching Blind to read—431 ;
choice of Miss. graduates—303 ;
Midd. Sch. Sc'.—285 ; Phonetic
used in—325-339.
- Technicians ; Hospital—375.
- Temples for Schools and Bar-
racks—51.
- Tents in Evang. Camp.—224.
,, equipment—527.
- Terminology (Sci.)—376.
- Tests ; Com. on Stand. Intel.—
209 ; (Ed'l)—289.
- Tests (Intell.)—289 ; Nat'l—290-
295 ; Mental Moral and Phys.
—293.
- Text books of Cht'nity—280.
- Theological controversy and
Miss.—263 ; training and the
Ch.—245.
- Thousand Characters—105 ; 110 ;
161 ; 310.
- T'ien Tsu Hui (Nat'l Foot Soc'y)
—419.
- Timothy Richard Prizes—443.
- Thrift ; Evidence of—35.
- Tongans ; Work for—235 ; 237.
- Tract Soc's coördinated—448.
,, (Relig.) Soc'y for China—
448, 449 ; Pub'ns of—478-482 ;
(W. China) ; pub'ns of—474,
475.
- Traffic ; Opium—488.
- Translations ; Recent—462.
- Training Class for Measurement
—290 ; Home for Sal'n Army
Off—490 ; leaders imperative
—242 ; 245 ; (Miss'y) inadequate
—152 ; Primary Teachers—105 ;
122 ; S. S. Teachers—194 ;
Teachers in E. China—272.
- Translation of Scriptures into
Turki—236 ; of Scriptures *vs*
Distribution—432 ; of Western
books—438.
- Travel ; Art. on—519.
,, Books of—451 ; 516.
- Treaties ; Extraterritoriality
previous to—48.
- Treaty of Wanghia—49.
- Tsinan and the Univ. Mor. Ass.
—60 ; and the Tao Yuan—62.
- Tsing Hua Coll.—3, 4.
- Turki ; Work among—235.
- Types of Chu Yin Tsu Mu—
322.
- Understaffing**—219.
- Unemployment ; Child Labor
and—34 ; in Gt. Brit. and
Miss'y sit'n—262.
- Unequal distribution of wealth
—17 ; 20.
- Unifying force of Ahungs—82 ;
pilgrims to Mecca—82.
- Unification in Ed'n—270-273.
,, of Thought—151.
- Union ; China S. S.—191 ; Coll. for
Women—307 ; efforts—103 ; 122 ;
270-273 ; 363 ; 374 ; 386 ; in Med.
Ed'l—271 ; 363-366 ; 374 ; 375 ;
Normal Schools—122.
- Unions ; Labor—29 ; 37 ; 40.
- United Cht'n Miss'y Soc'y—250.
- Unity (Church) N. C. C. and—
152 ; Coöperation and—93 ; 94 ;
114 ; 263 ; 375 ; of Chin. Islam—
79-81, 82 ; Religion ; Ass'n for
—65 ; Recent achievements
towards—247 ; 250.
- Universal Moral Ass'n—60 ; 61.
,, Ass'n for Unity of
Relig.—65.
- University ; C. C. Cht'n—270 ; of
Nanking ; Pub'ns of—477 ; of
Peking and Shantung Univ.—
270 ; Pek. Wom. Med. Coll.
and Shantung—270.

- Unoccupied territories; Bible in—435, 436.
- Vacation** Bible Sch.—129; 129; 195; Bible Sch.; Pub'ns of—477.
- Vice Commission—413.
- Village Life and the Ch.—127-130; education—129.
- Virtues; Classic—55; 70; 71.
- Vocational Int. of Miss. Sch. Grad.—303; Student—301-306.
- Volunteer Workers—206; 211; 218; 261; 434.
- Wage** (Living); See Living.
- Wanghia; Treaty of—49.
- War—61; 106.
- Weaknesses in Ch. Work—219-221.
- Weight Tables; Chin. and Amer. pupils' Ht. and—369.
- Welfare Ass'n; Moral—113; League (Moral)—413-415.
- Welfare Work in Ch'tn Ind.—396; in S. China—118; of the Sal. Army—491, 492; Coöperation in—129; Church's responsibility for—155.
- Wenchow; Work in—213-221.
- West China Ch'tn Ed. Union; Pub'ns of—472-474.
- West China Rel. Tract Soc'y Pub'ns of—474, 475.
- Women admitted to P. U. M. C.—364; Effort at Literacy among—105; (Labor of) and unemployment—34; (Labor of) in Ind.; Cause of—35; (Labor of) in Factories—29; 33; 43; Laws in regard to—508-511; (Schools for) needed—243; Union Coll. for—307; Workers; Lack of—220; Labor organ'ns—38; Problems; Books on—462.
- Works of Righteousness—60; 62.
- Workers (Church) served by Kuling Med. Miss.—387.
- Workers Increase in Chin.—91; 95; 235; 241; Lack of Women—220; Safeguarding—155.
- Workers Social status of—36.
- " " Welfare—104.
- World's Ass'n for Unity of Relig.—65.
- World's Religion—101.
- World Conf. on Boys' Work—163.
- Worship of Conf.—68; 70; 72.
- Writers; Chinese (Modern)—438; 441; Retreat for Ch'tn—445.
- Wuhan; Ch. Fed'n in—186.
- " Ind'l life in—31.
- Yangtsepoo** Community Center 422-425.
- Yen Hsi-shan and Shansi—486-489.
- Young Men's Ch'tn Ass'n and Stud. abroad—346; 351; and Ch'tn students—133; 159; and Ind'l sit'n—160; Coöp'n in Ch. Fed'n by—188; One Thous. Char. Course of—282; Present tendencies in—158-166; Religious activities of—165; 163; 282; Research Dep't of—165.
- Young People in Eng. responsive—261; (Work for) by China S.S. Union—191-195; by Ch'tn Endeavor—196, 197; by Epworth League—198-201.
- Young Women's Ch'tn Ass'n; Bible Courses of—282; Chin. leadership in—169; Ch. Fed'n and the—188; Coöp'n with N. C. C.—168; First Nat'l Conv. of—168; Growth of—170; Pub'ns of—474; Rel'n to Ch. of—168, 169; Student Ass'ns of—167.
- Yi Chuang; i. e. Common land for charity—21.
- Yu Ts'ai Kuan (Tr. Sch. for Mag'tes in Shansi)—487, 488.
- Yunnanfu; Miss'y work in—172.
- Zeal; Loss of—207; 209.
- " (Miss'y) of Chin. R. C. Sisters—268.
- Zwemer (Dr. S. M.); Visit to China of—89; 86.

